



Chipsmall Limited consists of a professional team with an average of over 10 year of expertise in the distribution of electronic components. Based in Hongkong, we have already established firm and mutual-benefit business relationships with customers from,Europe,America and south Asia,supplying obsolete and hard-to-find components to meet their specific needs.

With the principle of “Quality Parts,Customers Priority,Honest Operation,and Considerate Service”,our business mainly focus on the distribution of electronic components. Line cards we deal with include Microchip,ALPS,ROHM,Xilinx,Pulse,ON,Everlight and Freescale. Main products comprise IC,Modules,Potentiometer,IC Socket,Relay,Connector.Our parts cover such applications as commercial,industrial, and automotives areas.

We are looking forward to setting up business relationship with you and hope to provide you with the best service and solution. Let us make a better world for our industry!



Contact us

Tel: +86-755-8981 8866 Fax: +86-755-8427 6832

Email & Skype: info@chipsmall.com Web: www.chipsmall.com

Address: A1208, Overseas Decoration Building, #122 Zhenhua RD., Futian, Shenzhen, China

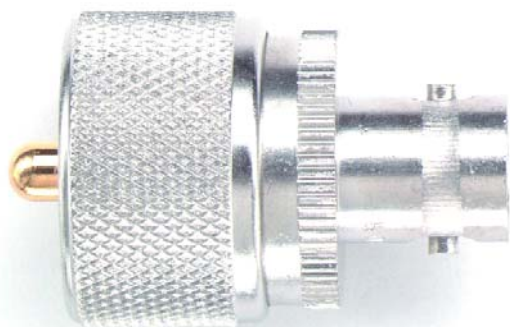

Model 3286
Adapter, BNC (Female) to UHF (Male)

Model 3286
Adapter, BNC (Female) to UHF (Male)

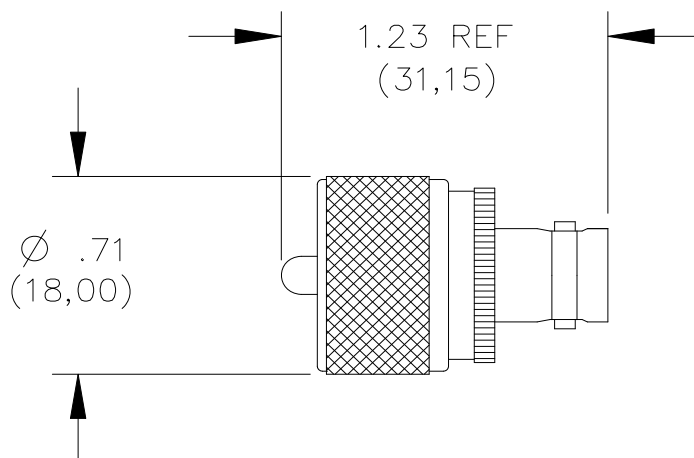

Materials

Body and Fittings – Brass, Tarnish Resistant Plating, Center Contact – Gold Plated Brass
Dielectric: PTFE

Ratings

Voltage: For *CE Compliance* and for personal safety, do not hold in hand when voltages exceed 33 Vrms/70 Vdc.
Maximum voltage for *hands free use*: 500 Vrms Max.

Operating Temperature: -55°C (-67°F) to +85°C (185°F)

Nominal Impedance: 50 Ohms

Ordering Information

Model: 3286

USA: Sales: 800-490-2361
Technical Support: technicalsupport@pomonatest.com
Fax: 425-446-5844

Europe: 31-(0) 40 2675 150 **International:** 425-446-5500

Where to Buy: www.pomonaelectronics.com

All dimensions are in inches. Tolerances (except noted): .xx = ±.02" (.51 mm),
.xxx = ±.005" (.127 mm). All specifications are to the latest revisions.
Specifications are subject to change without notice. Registered trademarks are
the property of their respective companies.