



Chipsmall Limited consists of a professional team with an average of over 10 year of expertise in the distribution of electronic components. Based in Hongkong, we have already established firm and mutual-benefit business relationships with customers from,Europe,America and south Asia,supplying obsolete and hard-to-find components to meet their specific needs.

With the principle of “Quality Parts,Customers Priority,Honest Operation,and Considerate Service”,our business mainly focus on the distribution of electronic components. Line cards we deal with include Microchip,ALPS,ROHM,Xilinx,Pulse,ON,Everlight and Freescale. Main products comprise IC,Modules,Potentiometer,IC Socket,Relay,Connector.Our parts cover such applications as commercial,industrial, and automotives areas.

We are looking forward to setting up business relationship with you and hope to provide you with the best service and solution. Let us make a better world for our industry!



Contact us

Tel: +86-755-8981 8866 Fax: +86-755-8427 6832

Email & Skype: info@chipsmall.com Web: www.chipsmall.com

Address: A1208, Overseas Decoration Building, #122 Zhenhua RD., Futian, Shenzhen, China





A Tallysman Accutenna®

TW3865 / TW3867 GPS L1/L2 + GLONASS G1/G2 + BeiDou B1 + Galileo E1

The TW3865 and TW3867 employ Tallysman's unique *Accutenna* technology providing dual band GPS L1 & L2, GLONASS G1 & G2, BeiDou B1, and Galileo E1 coverage and is especially designed for precision dual frequency positioning.

The antennas feature a precision tuned, circular dual feed, stacked patch element. The signals from the two orthogonal feeds are combined in a hybrid combiner, amplified in a wide-band LNA, then band-split for narrow filtering in each band and further amplified prior to recombination at the output.

The TW3867 has a strong pre-filter to mitigate inter-modulated signal interference from LTE and other cellular bands.

Both antennas offer excellent axial ratio and a tightly grouped phase center.

They cover GPS L2 (1227.6MHz), GLONASS G2 (1248MHz centre), GPS L1/WAAS/EGNOS/MSAS (1575.42MHz), GLONASS G1 (1602MHz, centre), BeiDou B1 (1561 MHz, 1589 MHz), and Galileo E1 (

The OEM antennas are supplied with a standard 60mm diameter circular ground plane, with a coaxial cable terminated with your choice of connector (right angle MCX is shown in the drawing). Mounting holes are provided for attachment to larger ground planes. Custom tuning and ground plane options may be available, depending on purchase level commitment.

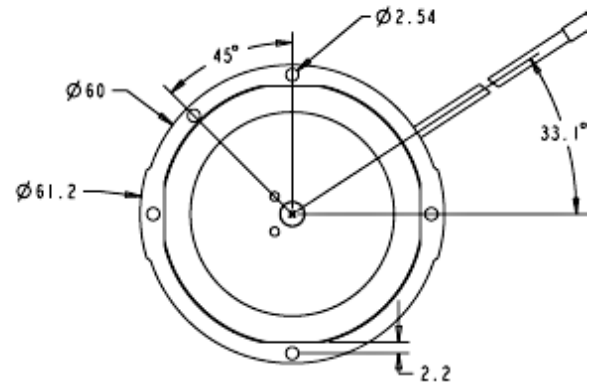

Applications

- Precision GPS position
- Dual Frequency RTK receivers
- Military & Security
- Network Timing and Synchronization

Features

- Very low Noise Preamp,
- Axial ratio: <2dB typ.; <1 dB at Zenith
- Tight Phase Center Variation
- LNA Gain 28 dB typ.
- Low current: 24 mA typ.
- ESD circuit protection: 15 KV
- Invariant performance from: +2.5 to 12VDC

Benefits

- Ideal for dual frequency RTK and PPP surveying systems
- Great multipath rejection
- Increased system accuracy
- Great signal to noise ratio
- RoHS and REACH compliant



TW3865 / TW3867 GPS L1/L2 + GLONASS G1/G2 + BeiDou B1 + Galileo E1

Specifications (Measured a Vcc = 3V, and Temperature=25°C)

Antenna

Patch Architecture	Circular, Dual Feed, Dual Stacked Patch
L2 Gain (100mm ground plane), 1227.6-1246MHz	3 dBic Min at Zenith on 100mm Ground Plane
L1 Gain (100mm ground plane), 1557MHz-1606MHz	4.5 dBic Min at Zenith on 100mm Ground Plane
Axial Ratio, over full bandwidth, both L1 & L2	<2dB typical; 1dB max. at Zenith, <3dB at horizon
1dB Bandwidth,	L2: 1227MHz-1250MHz L1: 1557MHz-1606MHz
Polarization	RHCP,

Electrical

Bandwidth	L2: 1213MHz-1261MHz (Filter bandwidth) L1: 1557 MHz-1606MHz (Filter bandwidth)	
Overall LNA Gain	28dB typ, 25 dB min, each of L1 and L2 Bands,	
Gain Variation with Temperature.	3dB max over operational temperature range	
LNA Noise Figure	1.5dB typ at 25°C (TW3865) 2.5dB typ at 25°C (TW3867)	
VSWR (at LNA output)	<1.5:1 typ. 1.8:1 max.	
Supply Voltage Range	+2.5 to 16VDC nominal, up to 50mV p-p ripple	
EMI Immunity	50V/Meter, excepting L1 +/-100MHz and L2 +/- 100MHz	
Supply Current	24mA typ. at 25°C, 25mA max at 75°C.	
ESD Circuit protection	15 KV air discharge.	
Out-of-Band Rejection	L1	L2
	<1450 MHz >40 dB	<1180 MHz >40 dB
	<1520 MHz >30 dB	<1190 MHz >30 dB
	>1650 MHz >35 dB	>1284 MHz >32 dB

Mechanicals & Environmental

Mechanical Size, Ground Plane	60mm diameter, 0.75mm thick, see mechanical drawing
Operating Temperature Range	-40°C to +85°C
Weight	70 g (excluding cable)
Attachment Method	Through hole screws in ground plane
Environmental	RoHS and REACH compliant
Shock	Vertical axis: 50 G, other axes: 30 G
Vibration	3 axis, sweep = 15 min, 10 to 200 Hz sweep: 3 G
Warranty	One year - parts and labour

Ordering Information

TW3865 - GPS L1/L2 + GLONASS G1/G2 + BeiDou B1 + Galileo E1 antenna	33-3865-xx-yyyy-zz
TW3867 - GPS L1/L2 + GLONASS G1/G2 + BeiDou B1 + Galileo E1 antenna	33-3867-xx-yyyy-zz
Where xx = connector type, yyyy = cable length in mm and zz = assigned by Tallysman for custom tuning	

Please refer to the Ordering Guide (<http://www.tallysman.com/orderingguide.php>) for the current and complete list of available connectors.



An ISO 9001:2015 Certified Company

Tel +1 613 591 3131
sales@tallysman.com

36 Steacie Drive, Ottawa ON K2K 2A9 Canada
Fax 613 591 3121

The information provided herein is intended as a guide only and is subject to change without notice. This document is not to be regarded as a guarantee of performance. Tallysman Wireless Inc. hereby disclaims any or all warranties and liabilities of any kind. © 2010 Tallysman Wireless Inc. All rights reserved. Rev 3.6