



Chipsmall Limited consists of a professional team with an average of over 10 year of expertise in the distribution of electronic components. Based in Hongkong, we have already established firm and mutual-benefit business relationships with customers from,Europe,America and south Asia,supplying obsolete and hard-to-find components to meet their specific needs.

With the principle of “Quality Parts,Customers Priority,Honest Operation,and Considerate Service”,our business mainly focus on the distribution of electronic components. Line cards we deal with include Microchip,ALPS,ROHM,Xilinx,Pulse,ON,Everlight and Freescale. Main products comprise IC,Modules,Potentiometer,IC Socket,Relay,Connector.Our parts cover such applications as commercial,industrial, and automotives areas.

We are looking forward to setting up business relationship with you and hope to provide you with the best service and solution. Let us make a better world for our industry!



Contact us

Tel: +86-755-8981 8866 Fax: +86-755-8427 6832

Email & Skype: info@chipsmall.com Web: www.chipsmall.com

Address: A1208, Overseas Decoration Building, #122 Zhenhua RD., Futian, Shenzhen, China



8

7

6

5

4

3

2

1

VICOR CONFIDENTIAL

THIS DOCUMENT AND THE DATA DISCLOSED HEREIN OR HERewith IS NOT TO BE REPRODUCED, USED OR DISCLOSED IN WHOLE OR IN PART TO ANYONE WITHOUT THE PERMISSION OF VICOR CORP.

REVISIONS

REV	DESCRIPTION	DATE	APPROVED
1	RELEASED PER E060461	02/01/06	PEI MB
2	REVISED PER E064534	10/17/06	REJH MB
3	REVISED PER E070923	05/01/07	SRG EM
4	REVISED PER E080938	05/06/08	SA REJH
5	REVISED PER E101309	10/22/10	KUK AR

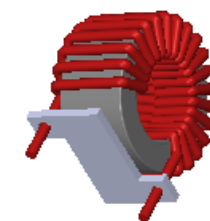
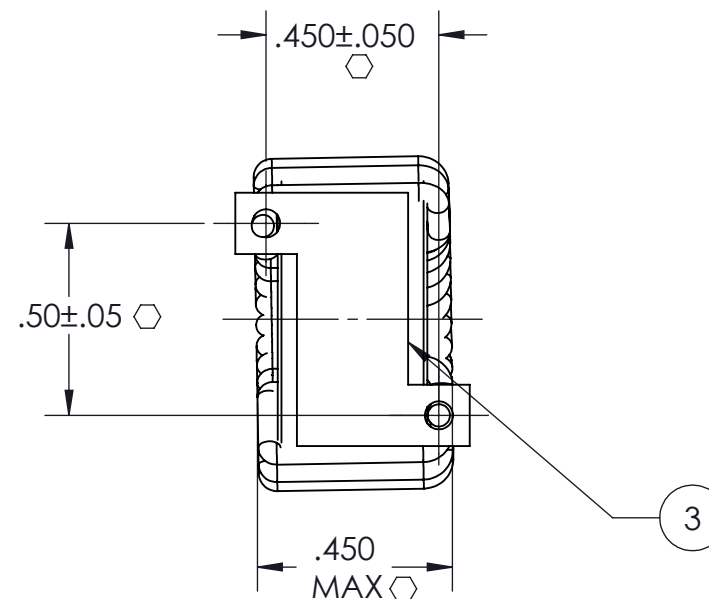
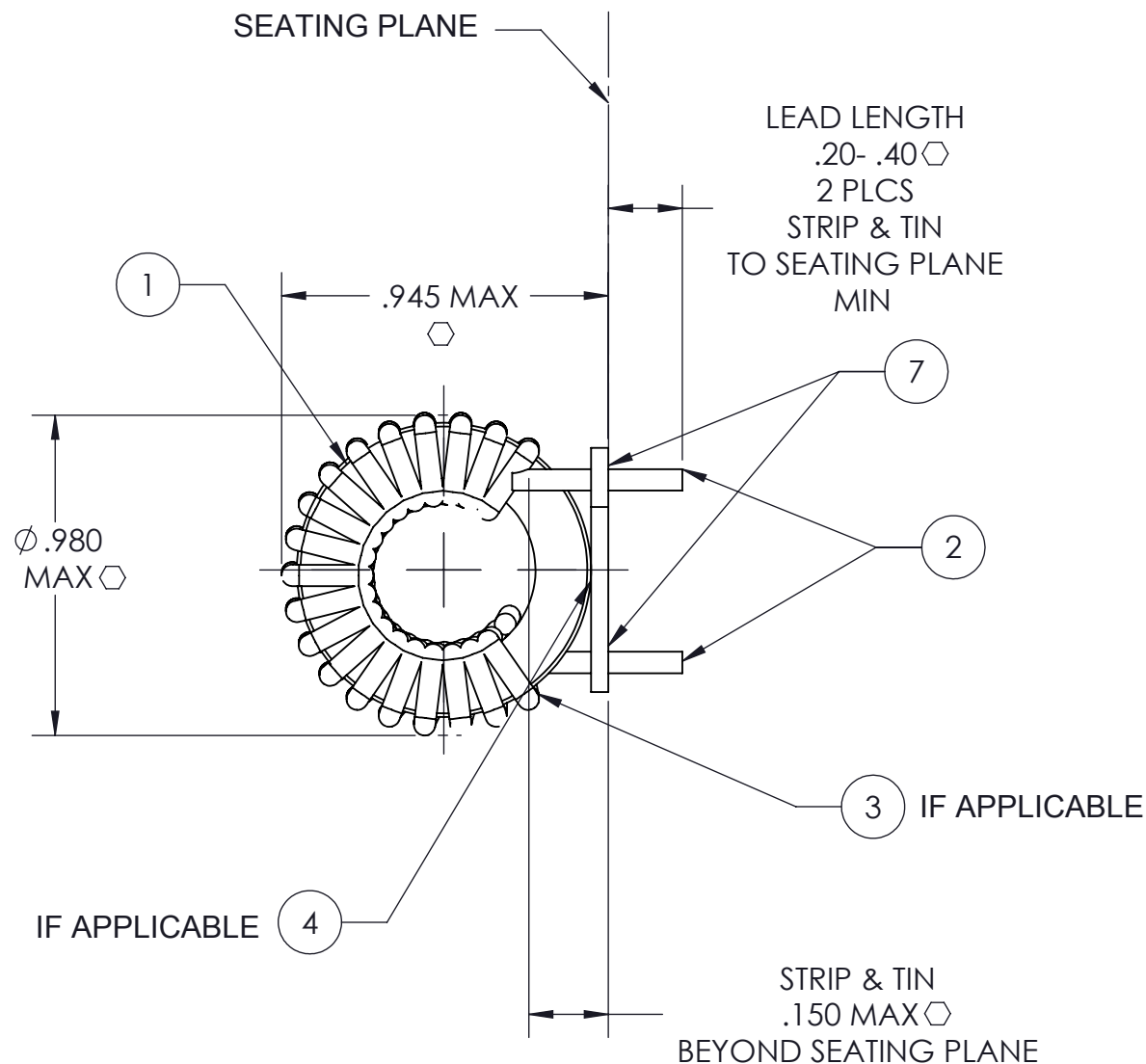

- NOTES:
1. ASSEMBLY TO BE FREE OF NICKS.
 2. WINDINGS TO BE EVENLY SPACED.
 3. RoHS COMPLIANT, LEAD FREE PER CST-0001 LATEST REVISION.
 4. GENERAL WORKMANSHIP STANDARDS FOR MAGNETIC COMPONENTS PER WS-0002.
 5. DENOTES CRITICAL CHARACTERISTIC FOR LOT INSPECTION.
 6. BOND THE MOUNT ITEM 3 IF APPLICABLE TO INDUCTOR LEADS (2 POSITIONS) USING EPOXY ITEM 7.

REF VICOR P/N 29764
REF VICOR P/N 33206

TEST	2	PRI	20	14.7-22.1	8 MAX
1 KHz @ 10 mV	ITEM NO.	WINDING	NO. OF TURNS	IND.(uH)	DC RES (mΩ)

MATERIAL	UNLESS OTHERWISE SPECIFIED DIMENSIONS ARE INCH [MM] TOLERANCES ARE: DECIMALS ANGLES X.XX [X.X] = ±0.01 [0.25] ±1° X.XXX [X.XX] = ±0.005 [0.127]
FINISH	
THIRD ANGLE PROJECTION	
DO NOT SCALE DRAWING	

DRAWN		DATE			
P.E.IENI		11/04/05			
ASSY DWG IND TOR .98 DIA 1W					
SIZE	CAGE CODE	DWG NO		REV	
B	67131	32065		5	
SCALE 4 : 1			SHEET 1 OF 1		

8

7

6

5

4

3

2

1