



Chipsmall Limited consists of a professional team with an average of over 10 year of expertise in the distribution of electronic components. Based in Hongkong, we have already established firm and mutual-benefit business relationships with customers from,Europe,America and south Asia,supplying obsolete and hard-to-find components to meet their specific needs.

With the principle of “Quality Parts,Customers Priority,Honest Operation,and Considerate Service”,our business mainly focus on the distribution of electronic components. Line cards we deal with include Microchip,ALPS,ROHM,Xilinx,Pulse,ON,Everlight and Freescale. Main products comprise IC,Modules,Potentiometer,IC Socket,Relay,Connector.Our parts cover such applications as commercial,industrial, and automotives areas.

We are looking forward to setting up business relationship with you and hope to provide you with the best service and solution. Let us make a better world for our industry!



Contact us

Tel: +86-755-8981 8866 Fax: +86-755-8427 6832

Email & Skype: info@chipsmall.com Web: www.chipsmall.com

Address: A1208, Overseas Decoration Building, #122 Zhenhua RD., Futian, Shenzhen, China



VICOR CONFIDENTIAL

THIS DOCUMENT AND THE DATA DISCLOSED HEREIN OR HEREWITH IS NOT TO BE REPRODUCED, USED, OR DISCLOSED IN WHOLE OR IN PART TO ANYONE WITHOUT PERMISSION OF VICOR CORP.

REV.	DESCRIPTION	DATE	APPROVED
1	Revised per E080380	JS 02/28/08	REJH

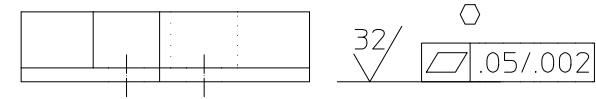
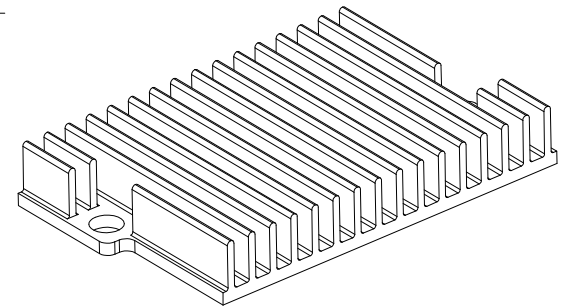
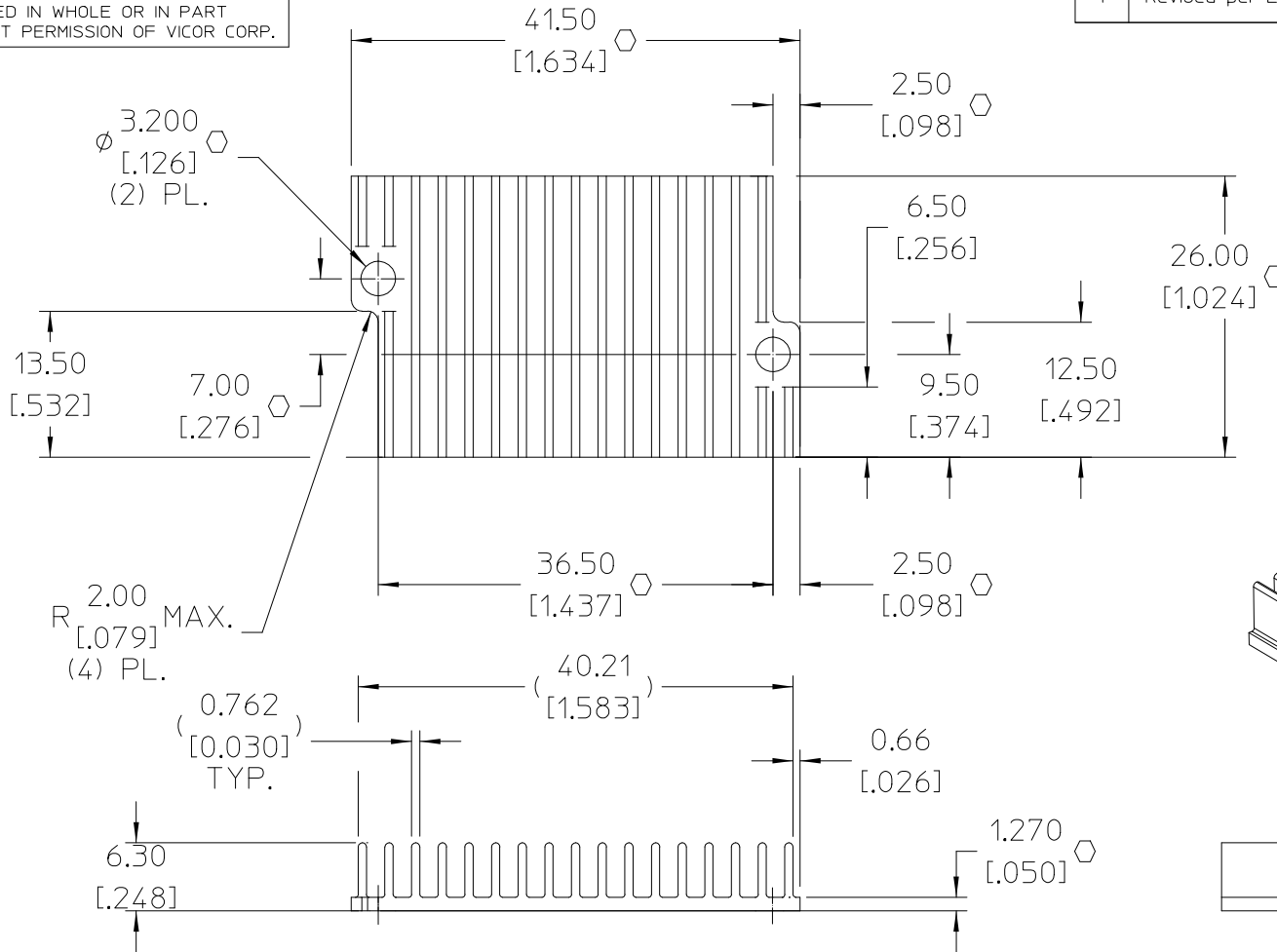

NOTES:

1. MAKE FROM VICOR PART NO. 32620.
2. FINISH: ELECTROLESS NICKEL PLATE PER ASTM B607-91, THICKNESS .000120" TO .000300" (3 TO 8µM).
3. REMOVE ALL BURRS AND SHARP EDGES.
4. "O" DENOTES CRITICAL CHARACTERISTIC FOR LOT INSPECTION.
5. RoHS COMPLIANT, LEAD FREE PER CST-0001 LATEST REVISION.

DRAWN BY <i>R.E.J.Hickey</i>		DATE 08/09/07			
UNLESS OTHERWISE SPECIFIED DIMENSIONS ARE MM [INCH] TOLERANCES ARE: DECIMALS ANGLES .XX= ±0.25 [.01] ±1° .XXX= ±0.127 [.005]					
THIRD ANGLE PROJECTION 		SIZE B	FSCM NO. 67131	DWG NO. 34069	REV 1
DO NOT SCALE DRAWING		SCALE 2:1	SHEET 1 OF 1		