



Chipsmall Limited consists of a professional team with an average of over 10 year of expertise in the distribution of electronic components. Based in Hongkong, we have already established firm and mutual-benefit business relationships with customers from,Europe,America and south Asia,supplying obsolete and hard-to-find components to meet their specific needs.

With the principle of “Quality Parts,Customers Priority,Honest Operation,and Considerate Service”,our business mainly focus on the distribution of electronic components. Line cards we deal with include Microchip,ALPS,ROHM,Xilinx,Pulse,ON,Everlight and Freescale. Main products comprise IC,Modules,Potentiometer,IC Socket,Relay,Connector.Our parts cover such applications as commercial,industrial, and automotives areas.

We are looking forward to setting up business relationship with you and hope to provide you with the best service and solution. Let us make a better world for our industry!



## Contact us

Tel: +86-755-8981 8866 Fax: +86-755-8427 6832

Email & Skype: info@chipsmall.com Web: www.chipsmall.com

Address: A1208, Overseas Decoration Building, #122 Zhenhua RD., Futian, Shenzhen, China



THIS DRAWING IS UNPUBLISHED. RELEASED FOR PUBLICATION  
 © COPYRIGHT - By - ALL RIGHTS RESERVED.

LOC	DIST	REVISIONS					
		P	LTR	DESCRIPTION	DATE	DWN	APVD
G	14		R1	REVISED PER ECO-11-004587	11MAR11	RK	HMR

<b>AMP</b> WIRE RANGE	Listed	LR7189 Certified
16-14 AWG SOLID OR STRANDED	16-14 AWG SOLID OR STRANDED	16-14 AWG SOLID OR STRANDED

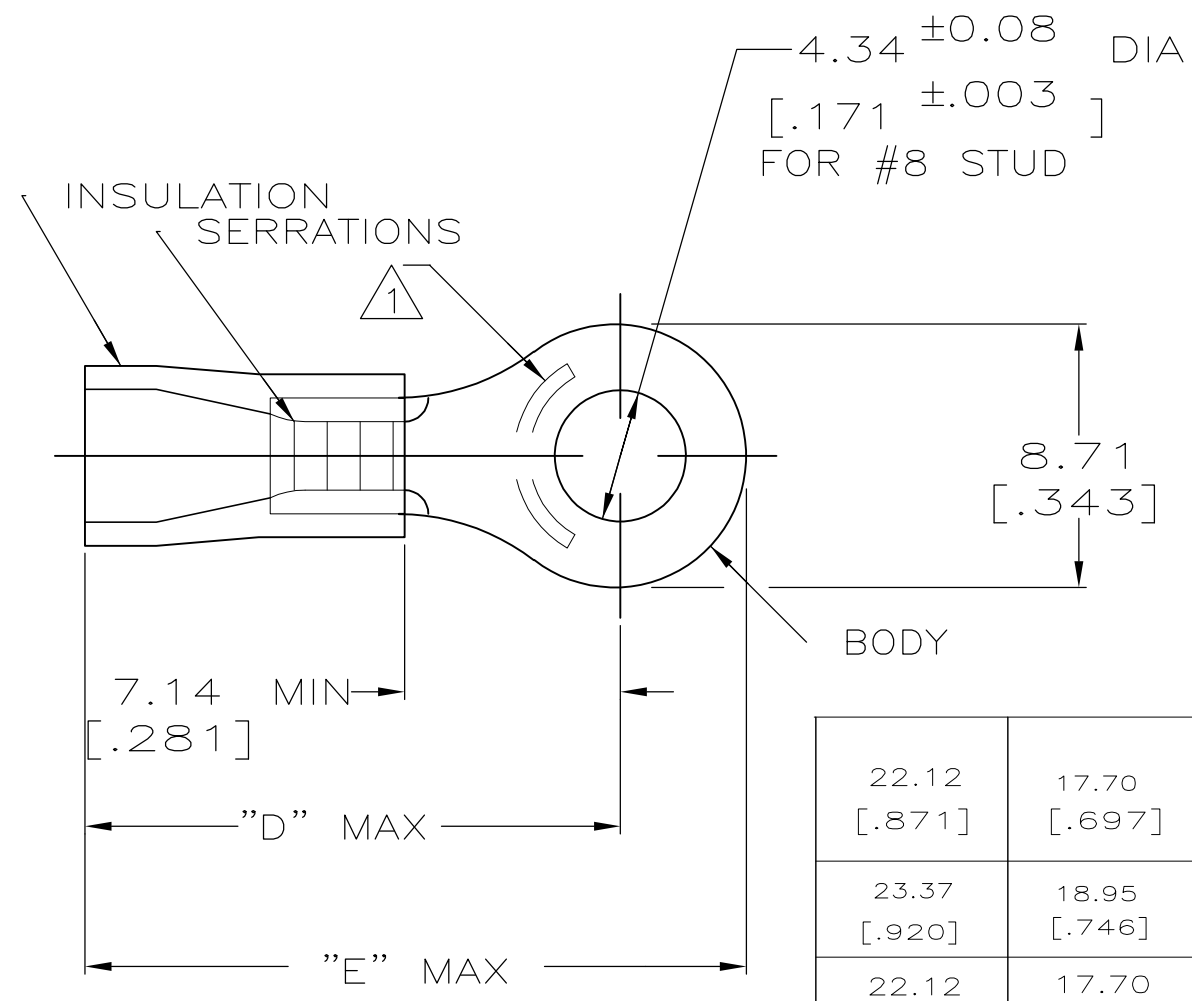

- 1 STAMP AMP 16-14\* APPROX AS SHOWN
- 2 TONGUE MATERIAL THK: 0.79<sup>±0.05</sup> [.031<sup>±0.002</sup>]
- 3 SUPERSEDED BY 8-34160-1
- 4 MATERIAL: BODY - CU PER ASTM B152  
SLEEVE - PVC, COLOR - BLUE

22.12 [.871]	17.70 [.697]	3.00-4.90 [.118-.193]	50	LOOSE PC, BAG	3 8-34160-5
			5	LOOSE PC, BLS	8-34160-4
			100	LOOSE PC, BOX	8-34160-1
23.37 [.920]	18.95 [.746]	3.81-.635 [.150-.250]	5000	ON TAPE, REEL	2-34160-3
			-	LOOSE PIECE	2-34160-2
22.12 [.871]	17.70 [.697]	3.00-4.90 [.118-.193]	5000	ON TAPE, REEL	2-34160-1
			-	LOOSE PIECE	34160
"E"	"D"	WIRE INSULATION DIA	QTY	PACKAGE TYPE	PART NUMBER

**AMP INCORPORATED**  
**CUSTOMER SERVICE SYSTEMS**

FOR ADDITIONAL PRODUCT INFORMATION OR COPIES OF DRAWINGS AND TECHNICAL DOCUMENTS  
 PRODUCT INFORMATION CENTER  
 1-800-522-6752

FOR APPLICATION TOOLING INFORMATION  
 TOOLING ASSISTANCE CENTER  
 1-800-722-1111

FOR ORDER ENTRY  
 1-800-526-5142

MAX RECOMMENDED OPERATING TEMPERATURE:  
 105°C [221° F]

VOLTAGE RATING:  
 N/A

CIRCULAR MIL AREA:  
 1.04-2.62mm<sup>2</sup> [2,050-5,180]  
 SOLID OR STRANDED

THIS DRAWING IS A CONTROLLED DOCUMENT.

DIMENSIONS: MM [INCHES]

TOLERANCES UNLESS OTHERWISE SPECIFIED:

0 PLC	± -
1 PLC	± -
2 PLC	± 0.20[.008]
3 PLC	± -
4 PLC	± -
ANGLES	± -

MATERIAL: TIN PER ASTM B545

DWN DK SCHRUM 02/08/93  
 CHK RE HERSEY 8/15/93  
 APVD M BARNABA 8/15/93  
 PRODUCT SPEC  
 UL 486A  
 APPLICATION SPEC  
 NOT AVAILABLE  
 WEIGHT -

**STE** TE Connectivity

NAME: TERMINAL, RING TONGUE, PLASTI-GRIP, WIRE SIZE, 16-14 AWG

SIZE: A3 CAGE CODE: 00779 DRAWING NO: C-34160 RESTRICTED TO: -

CUSTOMER DRAWING SCALE: 4:1 SHEET: 1 OF 1 REV: R1