



Chipsmall Limited consists of a professional team with an average of over 10 year of expertise in the distribution of electronic components. Based in Hongkong, we have already established firm and mutual-benefit business relationships with customers from,Europe,America and south Asia,supplying obsolete and hard-to-find components to meet their specific needs.

With the principle of “Quality Parts,Customers Priority,Honest Operation,and Considerate Service”,our business mainly focus on the distribution of electronic components. Line cards we deal with include Microchip,ALPS,ROHM,Xilinx,Pulse,ON,Everlight and Freescale. Main products comprise IC,Modules,Potentiometer,IC Socket,Relay,Connector.Our parts cover such applications as commercial,industrial, and automotives areas.

We are looking forward to setting up business relationship with you and hope to provide you with the best service and solution. Let us make a better world for our industry!



Contact us

Tel: +86-755-8981 8866 Fax: +86-755-8427 6832

Email & Skype: info@chipsmall.com Web: www.chipsmall.com

Address: A1208, Overseas Decoration Building, #122 Zhenhua RD., Futian, Shenzhen, China





3442-00XX Compliant Pin Tool

Instructions for the installation of Compliant Pin Connectors using the 3442-00XX Insertion Platen

General

The 3M 3442-00XX Insertion Platen was designed to aid in pressing compliant pin connectors onto printed circuit boards. There is one insertion platen for each connector position.

The platen is designed to be used with a two (2) or three (3) ton Arbor press. The press can either be hand operated or pneumatic.

The platen can be used with or without the latch/ejectors in place.

PC Board Support

To protect the compliant pin during the connectors installation, a support for the PC board is necessary.

This support should be approximately 3/4 inch thick. It can either be drilled with the same hole pattern as the PC board, or it could have milled grooves in a cross hatch pattern.

This support should be supplied by the customer.

Tool Preparation

If the press has an adjustable ram, set the shut height to $1.50 \pm .002$ inches. This would be the distance between the ram and the top of the PC board when it is mounted on the support block on top of the base of the press. The ram should be fully extended at this point.

Assembly Procedure

1. Place the PC board on the designated support.
2. Place the insertion platen onto the header, making sure the header pins align with the corresponding holes in the platen.
3. Align the header pins with the holes in the PC board. Slightly push to pre-seat the connector on the board.
4. Making sure the platen and connector are directly under the press ram, actuate the press ram.

Caution: remove hands before actuating ram.

5. Return ram to original position and remove the Platen from the connector.

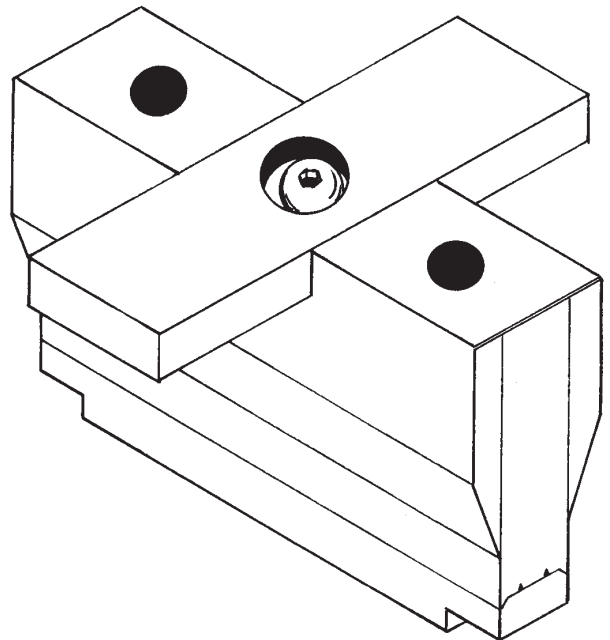
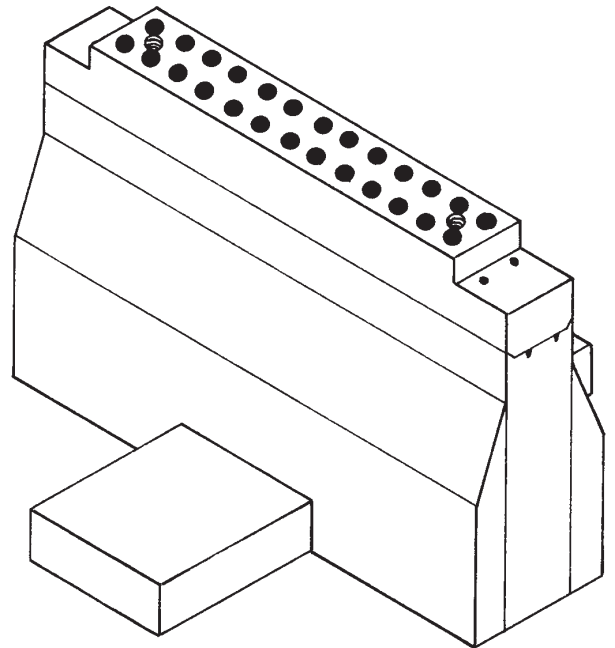

3442-00XX

Insertion Platen Number	Connector Position
3442-0048	10
3442-0049	14
3442-0050	16
3442-0051	20
3442-0052	24
3442-0053	26
3442-0054	30
3442-0055	34
3442-0056	40
3442-0057	50
3442-0058	60
3442-0059	64

For technical, sales or ordering information, contact 3M at:

Phone: 1-800-225-5373

Fax: 1-800-325-5329

Important Notice

All statements, technical information, and recommendations related to Seller's products are based on information believed to be reliable, but the accuracy or completeness thereof is not guaranteed. Before utilizing the product, the user should determine the suitability of the product for its intended use. The user assumes all risks and liability whatsoever in connection with such use.

Any statements or recommendations of the Seller which are not contained in the Seller's current publications shall have no force or effect unless contained in an agreement signed by an authorized office of Seller. The statements contained herein are made in lieu of all warranties, express or implied,

including but not limited to the implied warranties of merchantability and fitness for a particular purpose which warranties are hereby expressly disclaimed.

SELLER SHALL NOT BE LIABLE TO THE USER OR ANY OTHER PERSON UNDER ANY LEGAL THEORY, INCLUDING BUT NOT LIMITED TO NEGLIGENCE OR STRICT LIABILITY, FOR ANY INJURY OR FOR ANY DIRECT OR CONSEQUENTIAL DAMAGES SUSTAINED OR INCURRED BY REASON OF THE USE OF ANY OF THE SELLER'S PRODUCTS THAT WERE DEFECTIVE.



Electronic Products Division

6801 River Place Blvd.
Austin, TX 78726-9000



50% Recycled
10% Post Consumer Waste

Printed in USA.

© 3M 1995 34-7038-0818-7(252.0)LP