



Chipsmall Limited consists of a professional team with an average of over 10 year of expertise in the distribution of electronic components. Based in Hongkong, we have already established firm and mutual-benefit business relationships with customers from,Europe,America and south Asia,supplying obsolete and hard-to-find components to meet their specific needs.

With the principle of “Quality Parts,Customers Priority,Honest Operation,and Considerate Service”,our business mainly focus on the distribution of electronic components. Line cards we deal with include Microchip,ALPS,ROHM,Xilinx,Pulse,ON,Everlight and Freescale. Main products comprise IC,Modules,Potentiometer,IC Socket,Relay,Connector.Our parts cover such applications as commercial,industrial, and automotives areas.

We are looking forward to setting up business relationship with you and hope to provide you with the best service and solution. Let us make a better world for our industry!



Contact us

Tel: +86-755-8981 8866 Fax: +86-755-8427 6832

Email & Skype: info@chipsmall.com Web: www.chipsmall.com

Address: A1208, Overseas Decoration Building, #122 Zhenhua RD., Futian, Shenzhen, China





Pak 50E and 50 Assembly Application Tools

Instructions

The assembly of 3M™ PAK 50E connectors and 3M™ 3365 Cable can be accomplished when using the 3M™ 3443-128 Series Locator Plate and the 3M™ 3640 or 3335 Assembly Press.

Tools required:

Product #	Description	Stock Number
3443-128	Locator Plate	80-4000-1626-9
3640	Assembly Press	80-6100-7882-8
3335	Assembly Press	80-6100-3208-0 (alternate to the 3640)
3436-1J	Shut Height Gage	78-8118-0908-2
3442-126	Platen	80-6104-7838-2

PAK 50E Connector

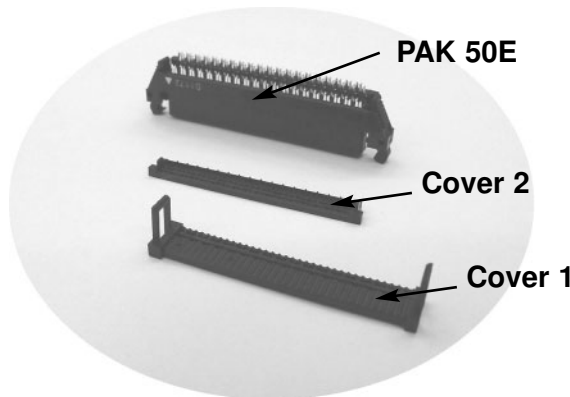

Assembly Press Setup

1. The 3M™ 3436-1J Shut Height Gauge was shipped with the locator plate. The setting height is inscribed on the side of the gauge. The setting of 18 1/2 is for the 3M™ 3640 Press and the setting of 19 is for the 3M™ 3335 Press.
2. Place the shut height gauge on the base of the press and bring down the shaft of the press onto the surface of the shut height gauge lightly. Adjust the shaft length by turning the adjusting knob on the top of the shaft (3640) or the adjusting collar on the lower portion of the shaft of the press (3335) so that the press handle comes completely down with only a small amount of pressure from the press shaft on the shut height gauge. On the 3335 only, tighten the locking collar. The shut height distance is now set.
3. Place the 3M™ 3442-126 Platen on the end of the press shaft and lock it in place by sliding the holding clamp on the platen into the groove on the press shaft. Your assembly press is now setup.

Note: *The 3640 in the picture is shown with the separately purchased 3M™ 3771 Base Plate which adds stabilization to the press. It's use is optional. The 3335 Heavy Duty press is also applicable, but not shown.*

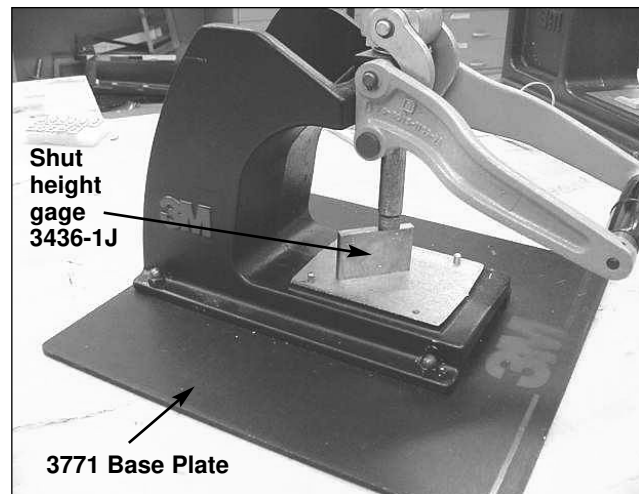

Assembly Press Setup

Locator Plate Setup

1. The 3M™ PAK 50 Connector may only be terminated to the end of two cables. It may not be daisy-chained.
2. Place the cable stops into the holes in the locator plate.
3. Using a piece of cable, adjust the cable guide so that the cable will be positioned in the center of the locator plate when the edge of the cable is against the guide. The small ridges on the surface of the locator plate will help to hold the cable straight and in position for termination.
4. The locator plate can now be positioned on the press base under the platen. Some operators prefer to place the locator plate into the press after they have prepped the cable and connector for termination. If you prefer this method, be sure that the cable and connector do not move when you place the locator plate into place on the press.

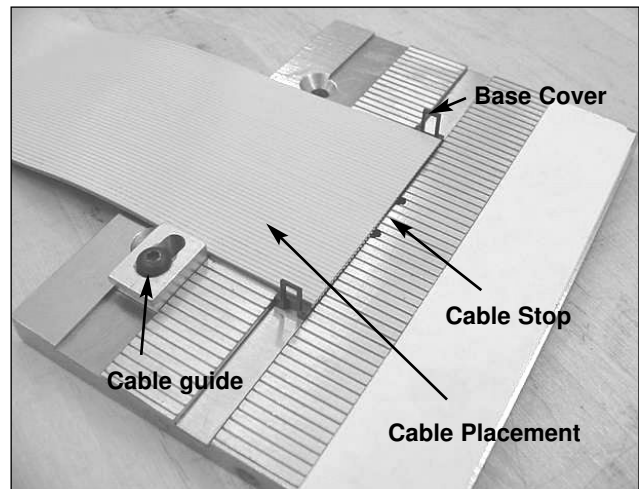

Locator Plate Setup

Connector Assembly

Note: For clarity, the pictures show the cable and connector being positioned on the locator plate while it is on the table top. This can also be done while the plate is in position on the press.

The 3M™ PAK 50 Connector is made to be terminated to two pieces of 3M™ 3365 Cable. This is somewhat unusual for an insulation displacement style connector. The connector has two rows of contacts. One row of contacts protrudes further from the connector body than the other. Each row will terminate one of the two pieces of cable. One piece of cable will end up against the connector body. Cover 2 will end up between the two pieces of cable. The second piece of cable will be on top of Cover 2. Cover 1 will latch to the body and be on top of the second piece of cable.

1. Place Cover 1 into the slot on the locator plate.
2. Place the first piece of cable against the cable guide, between the plastic latches on Cover 1, and with its end against the cable stops. When the cable is pressed against the ridges on the surface of the locator plate, it will become square to the cover groove and the cover should slide into position aligned with the cable. Make sure that the cable is in the grooves on Cover 1.
3. Maintain pressure on the cable with your hand to keep the cable in position.

PAK 50E Connector

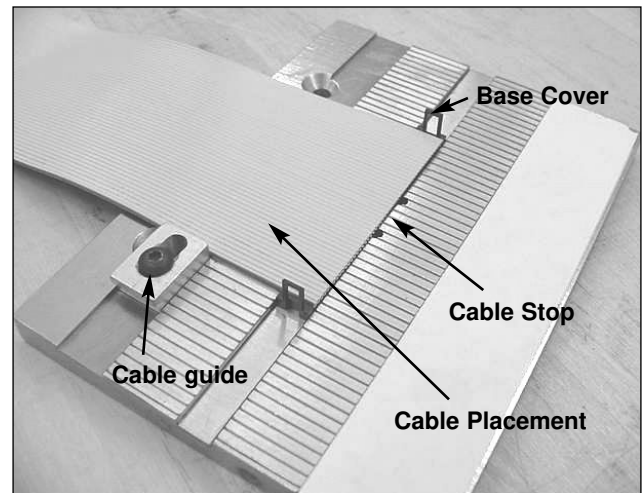
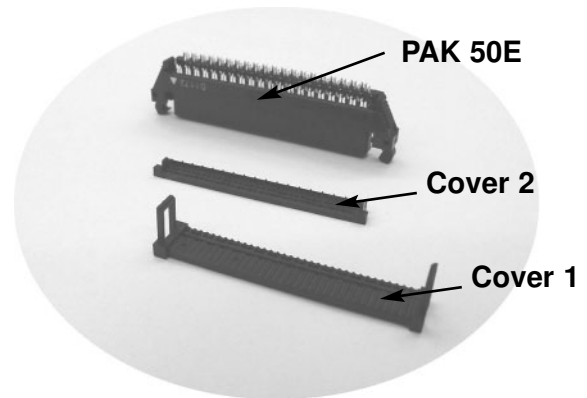

Connector Assembly Steps 1, 2, 3

4. Cover 2 has a cable stop rib on one edge. Place Cover 2 on top of the cable and between the latches of Cover 1. The cable stop ridge should be on the edge of Cover 2 that is in the center of Cover 1.

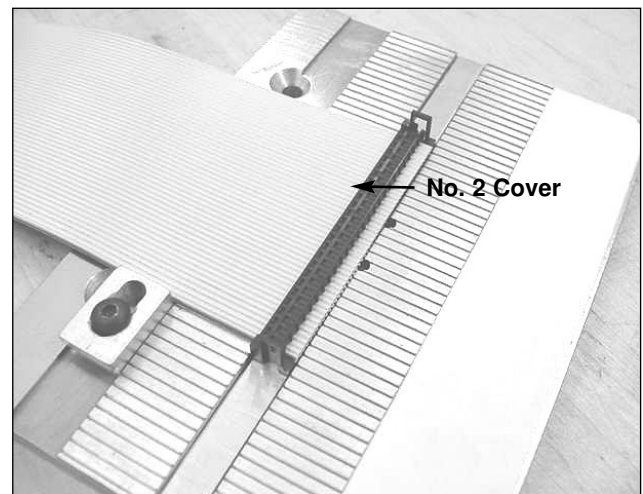

Connector Assembly Step 4

5. Place the second piece of cable between the latches of Cover 1, into the ridges of Cover 2 with its end against the cable stop ridge of Cover 2.
6. Maintain pressure on the cables with your hand to keep the cables in position.

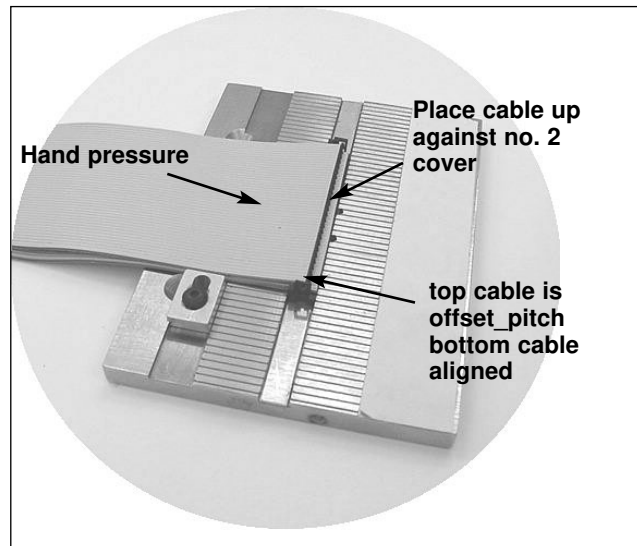

Connector Assembly Steps 5, 6

7. Make sure that the tips of the ejector latch on the connector are pushed in toward the center of the connector.
8. Place the connector body on top of the cable engaging the protruding cover latches with the appropriate slots on the connector body. The connector may be pressed down by hand for an initial placement.

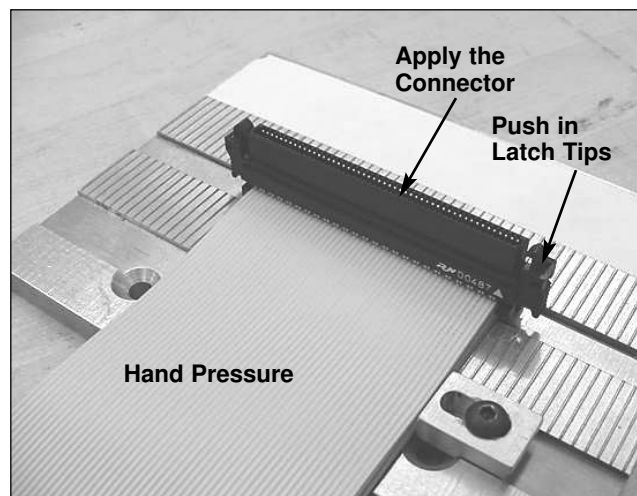

Connector Assembly Steps 7, 8

9. If you did the assembly on the table top, place the locator plate and cables and connector together onto the base of the assembly press. Take care that the cables do not move and that the connector does not slip out of the groove on the locator plate.
10. To complete the assembly, push the assembly press handle down until the press handle stops against the press frame. This will press the connector onto the cable permanently.
11. Lift the press handle and remove the terminated connector and cables from the locator plate.
12. Inspect the finished assembly to assure that the cover latches are latched fully. If the cover latches are not completely latched, a minor shut height adjustment may be required.

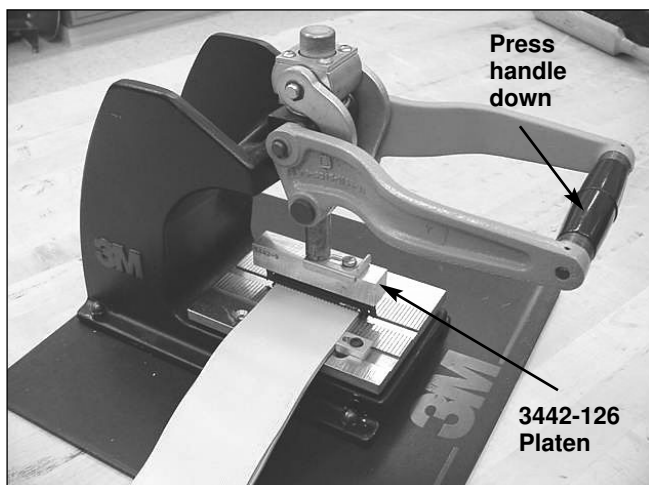

Connector Assembly Steps 9, 10, 11, 12

⚠ Caution: Do not over terminate!

3M is a trademark of 3M.

IMPORTANT NOTICE

Before using this product, you must evaluate it and determine if it is suitable for your intended application. You assume all risks and liability associated with such use.

Warranty; Limited Remedy; Limited Liability. This product will be free from defects in material and manufacture for one year from the date of purchase. **3M MAKES NO OTHER WARRANTIES INCLUDING, BUT NOT LIMITED TO, ANY IMPLIED WARRANTY OF MERCHANTABILITY OR FITNESS FOR A PARTICULAR PURPOSE.** If this product is defective within the warranty period stated above, your exclusive remedy shall be, at 3M's option, to replace or repair the 3M product or refund the purchase price of the 3M product. **Except where prohibited by law, 3M will not be liable for any loss or damage arising from this 3M product, whether direct, indirect, special, incidental or consequential regardless of the legal theory asserted.**

3M

Electronic and Interconnect Solutions Division
6801 River Place Blvd.
Austin, TX 78726-9000
www.3M.com/eisd



*Printed on 40% recycled paper
with 10% post-consumer*

Litho in USA
©3M 2003 78-8133-3511-0-A