



Chipsmall Limited consists of a professional team with an average of over 10 year of expertise in the distribution of electronic components. Based in Hongkong, we have already established firm and mutual-benefit business relationships with customers from,Europe,America and south Asia,supplying obsolete and hard-to-find components to meet their specific needs.

With the principle of “Quality Parts,Customers Priority,Honest Operation,and Considerate Service”,our business mainly focus on the distribution of electronic components. Line cards we deal with include Microchip,ALPS,ROHM,Xilinx,Pulse,ON,Everlight and Freescale. Main products comprise IC,Modules,Potentiometer,IC Socket,Relay,Connector.Our parts cover such applications as commercial,industrial, and automotives areas.

We are looking forward to setting up business relationship with you and hope to provide you with the best service and solution. Let us make a better world for our industry!



## Contact us

Tel: +86-755-8981 8866 Fax: +86-755-8427 6832

Email & Skype: info@chipsmall.com Web: www.chipsmall.com

Address: A1208, Overseas Decoration Building, #122 Zhenhua RD., Futian, Shenzhen, China



# 3M™ Organic Vapor Diffusion Monitor 3500/3510 & 3520/3530



## Overview/Benefits

- Simple and convenient.
- No batteries, hoses or pumps to operate.
- Easy to use. Just clip the monitor to shirt lapel, collar, or pocket.
- Versatile. 3M monitors can also be used for area monitoring, if sufficient air flow exists.
- Analysis options. 3M monitors can be analyzed in the lab of your choice or returned to a 3M contracted lab for analysis.
- Confidence. Our testing facilities are accredited by the American Industrial Hygiene Association.
- Comfort. 3M monitors are small and lightweight and will not interfere with employee activities.

The 3M™ Diffusion Monitor is a sampling device designed to measure average concentrations of certain contaminants over a measured time interval. It can be used for either personal or area monitoring. As a personal monitor, it is worn near the breathing zone of individuals exposed to potentially hazardous environments. When used as an area monitor, hang it away from walls, corners, table tops, or other regions where the air movement in the room may be limited.

## Product Information

3500 and 3510 organic vapor diffusion monitors contain a single charcoal adsorbent pad. The 3500 monitor is designed to be analyzed by the user or by an independent laboratory. The 3510 includes a prepaid analysis for up to three compounds per monitor.

3520 and 3530 organic vapor diffusion monitors contain two charcoal adsorbent pads for increased capacity. The 3520 monitor is designed to be analyzed by the user or by an independent laboratory. The 3530 includes a prepaid analysis for up to three compounds per monitor.

3M Monitor prepaid analysis services will be provided by an American Industrial Hygiene Association (AIHA®) Accredited Laboratory. Confidentiality of customer analysis results will be maintained. The list of the compounds which are included in the prepaid analysis service for the 3510 and 3530 monitors is given in the User Instructions. Up to 3 compounds may be selected from this list for analysis. A written report will be quickly returned to document the results of the analysis.

Meets accuracy of +/- 25% for many organic vapors. Please see 3M Technical Data Bulletins for more information.

Store in an area free of organic vapors.

**Shelf life is 18 months from date of manufacture. Expiration date is printed on packaging in MM\_YY format.**

Sampling times will vary according to contaminant concentrations and environmental conditions such as humidity. Sampling times should be selected for comparison with appropriate exposure limits. For details on appropriate compounds and sampling times, refer to the Organic Vapor Sampling and Analysis Guide.

For more information, please call 3M Technical Service at 1-800-243-4630 or see the User Instructions.

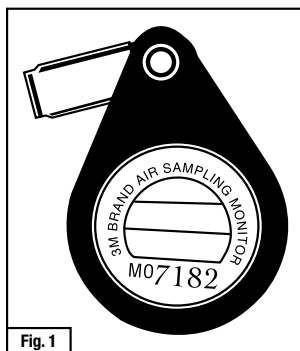

Fig. 1

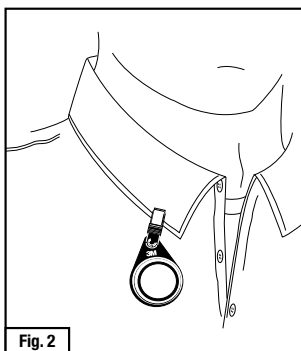

Fig. 2

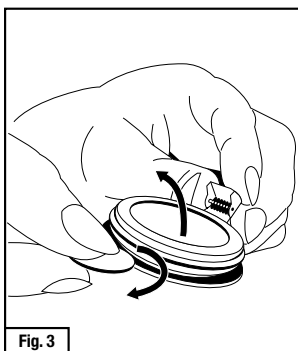

Fig. 3

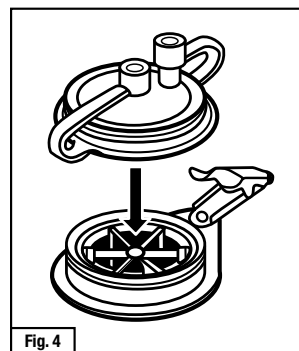

Fig. 4

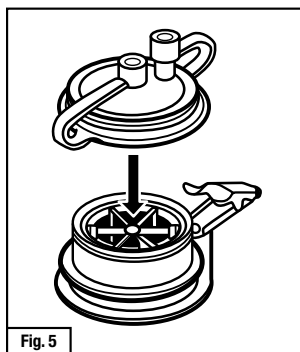

Fig. 5

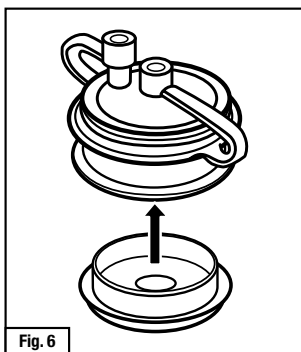

Fig. 6

## Sampling Instructions

1. Remove the diffusion monitor from the can.
  2. Before monitoring, record the following information in your data log and on the enclosed form:
    - 1) monitor serial number,
    - 2) sampling date,
    - 3) employee or area ID,
    - 4) temperature and relative humidity,
    - 5) compounds to be analyzed.
  3. Record the date, employee or area ID and sampling start time on the monitor label (Fig. 1).  
**DO NOT REMOVE WHITE FILM AND PLASTIC RING.**
  4. Monitor can be used as an area or personal sampler. For personal sampler attach the monitor near employee breathing zone (Fig. 2). When used as an area monitor, hang it away from walls, corners, table tops, or other regions where the air movement in the room may be limited.
  5. After sampling period is ended, remove plastic ring and white film from the monitor (Fig. 3).  
**MOVE TO STEP 6 IMMEDIATELY.**
  6. **3500/3510:** Snap elution cap (with plugs) onto main monitor body (Fig. 4). Be sure the two port plugs are secured. Record final sampling time on the back of monitor. Monitor is now ready for shipment.  
**3520/3530:** Snap elution cap (with plugs) onto the top of the primary body (Fig. 5). Separate the primary body and secondary body sections. Snap the bottom cup (no plugs) into the bottom of the primary section (Fig. 6). Snap elution cap on the secondary body. Monitor is now ready for shipment.
- NOTE:** The primary and secondary sections should have the same identification numbers.
7. Return monitor and short plastic straw to can and close with plastic lid provided.
  8. **3500 or 3520:** Monitors do not include prepaid analysis; therefore, **DO NOT RETURN TO 3M FOR ANALYSIS**. Please see [www.aiha.org](http://www.aiha.org) for a list of AIHA® accredited laboratories. A detailed analysis procedure is available from 3M.  
**3510 or 3530:** Send monitor plus completed analysis request form to:

EMSL Analytical, Inc.  
1830 Elm St. SE  
Minneapolis, MN 55414

Good industrial hygiene practice indicates that a blank monitor be included with each set of samples to check for any contamination of the samples. The blank is a monitor which has been handled in the same manner as the sample monitors, but has not been exposed to the atmosphere in the area being monitored.

**NOTE:** Certain compounds (e.g. acetone, methyl ethyl ketone, vinyl acetate, etc.) may show a decreased recovery when sampled in high relative humidity. Refrigerate and/or expedite for analysis to help ensure accurate results.

## Reading the Report

The "Concentration" Column (circled) is where you will find the average concentration based upon the amount found by the lab and the time that you reported. This average may be converted to an 8-hour time weighted average if you wish to compare it against an 8-hour exposure limit.

### Scenario 1:

Sample was for 6 hours and worker was NOT exposed to contaminants for the remaining 2 hours. The 8-hour TWA may be determined using the following equation:

$(\text{Report Concentration} \times 6 \text{ hours})$   
8 hours

### Scenario 2:

Sample was for 6 hours, but worker has the same exposure for the remaining 2 hours. Since the exposure in the remaining 2 hours is the same, the report concentration will be the same as the 8-hour TWA.

Exposure levels may be entered into the 3M™ Select Software on [3M.com/ServiceLifeSoftware](http://3M.com/ServiceLifeSoftware) to determine appropriate respirator choices or to help determine cartridge change schedules.

Your returned Monitor Analysis Report will look like this:



**Diffusional Monitor  
Analysis Report**



Analytical Service  
3M Personal Safety Division  
Telephone: 800-243-4630

EMSL Analytical, Inc.  
1830 Elm St. SE  
Minneapolis, MN 55414



Report Number: _____		Page 1 of 1	
No. of Monitors: 2	Test Method Used: 3M OVM Monitor		
Analysis Performed: Date	Report Date: Date		
Analyst By: Analyst Name			

Project Manager  
\* 3M Analytical Services provided by  
EMSL Analytical, Inc.  
(AUSA-LAP Lab - ID 10198)

Client: Company Name \_\_\_\_\_  
Client Contact \_\_\_\_\_  
Address \_\_\_\_\_  
City, State Zip \_\_\_\_\_

User Identification	Monitor Code	Sampling Date	Sampling Time	Weight Micrograms	Concentration		Footnote
		Compound(s)			mg/m <sup>3</sup>	PPM	
Monitor 1	MC9261	11/2/16	615 min.	178	10.2	2.36	gg2, ib
		Ethyl Benzene		<3.00	<0.146	<0.0484	gg2
		Methyl Ethyl Ketone		2250	114	30.2	gg2
Monitor 2	MC9495	11/2/16	370 min.	272	21.9	9.18	gg2, ib
		Acetone		-2.99	<0.311	<0.0774	gg2
		Cyclohexanone		332	27.6	5.82	gg2
		n-Butyl Acetate					

The samples associated with this report were received in good condition unless otherwise noted. This report relates only to those items tested as received by the laboratory. The QC data associated with the sample results meet the recovery and precision requirements established by the laboratory, unless specifically indicated. The final results are not field blank corrected, unless otherwise noted. The laboratory is not responsible for final results calculated using sampling times that have been provided by non-laboratory personnel. This report may not be reproduced except in full and without written approval by EMSL Analytical, Inc.

Footnote:  
 <= This analyte not detected at or above the reported limit.  
 gg2 The sample was authorized for analysis past the method specified holding time.  
 ib Unidentified compounds are present in the sample.

3M warrants only the accuracy of the sampling/analytical methods and the data obtained thereby. 3M disclaims responsibility for any comparisons of test data to any existing or future health and safety standards as to whether such standards are or are not adequate to insure the safety of persons or property.

**Important Notice to User**

The following warranty is made in lieu of all other warranties express or implied, including but not limited to the implied warranties of merchantability and fitness for purpose. 3M Personal Safety Division (3M PSD) products sold will meet the physical standards and properties set forth in the applicable product specification datasheets issued by 3M. 3M's only obligation under this warranty shall be to replace such quantity of 3M PSD products proved to be defectively manufactured by failing to meet the aforementioned specification data sheets, and to be responsible for any third party personal injuries directly caused by said defects. Except as provided above 3M shall not be liable or responsible for any loss, damage, or liability, direct, indirect, incidental, special or consequential, arising out of the sale, use or misuse, or the inability to use products by the user.

Report: RPT 01.04

Please review the user instructions packaged with the product or contact 3M Technical Service at 1-800-243-4630 if you have any questions or require additional information.

## WARNING

### Do Not Use For:

- Ammonia, Carbon Monoxide; Ethylene Oxide\*; Formaldehyde#; Hydrogen Sulfide; Isocyanates; Methane; Ethane; Propane; Methyl Alcohol (Methanol); Methyl Chloride; Methyl, Dimethyl, Trimethyl Amines; Organic Solids; Sulfur Dioxide
- Reactive or polar compounds such as amines, phenols, aldehydes, and low molecular weight alcohols
- Extremely low concentrations within a sampling period of less than 8 hours

\*Ethylene Oxide can be monitored using 3M™ Ethylene Oxide Monitor 3550/3551.

#Formaldehyde can be monitored using 3M™ Formaldehyde Monitor 3720/3721.

For product use instructions and limitations, see User Instructions Guide.



**Personal Safety Division**  
3M Center, Building 0235-2W-70  
St. Paul, MN 55144-1000

### For more information: In U.S.

Technical Assistance 1-800-243-4630  
Customer Care Center 1-800-328-1667  
[3M.com/WorkerSafety](http://3M.com/WorkerSafety)

### In Canada

Technical Assistance 1-800-267-4414  
Customer Care 1-800-364-3577  
[3M.ca/Safety](http://3M.ca/Safety)

3M and all other trademarks used herein are trademarks of 3M Company, used under license in Canada.  
© 3M 2016. All rights reserved.