



Chipsmall Limited consists of a professional team with an average of over 10 year of expertise in the distribution of electronic components. Based in Hongkong, we have already established firm and mutual-benefit business relationships with customers from,Europe,America and south Asia,supplying obsolete and hard-to-find components to meet their specific needs.

With the principle of "Quality Parts,Customers Priority,Honest Operation,and Considerate Service",our business mainly focus on the distribution of electronic components. Line cards we deal with include Microchip,ALPS,ROHM,Xilinx,Pulse,ON,Everlight and Freescale. Main products comprise IC,Modules,Potentiometer,IC Socket,Relay,Connector.Our parts cover such applications as commercial,industrial, and automotives areas.

We are looking forward to setting up business relationship with you and hope to provide you with the best service and solution. Let us make a better world for our industry!



Contact us

Tel: +86-755-8981 8866 Fax: +86-755-8427 6832

Email & Skype: info@chipsmall.com Web: www.chipsmall.com

Address: A1208, Overseas Decoration Building, #122 Zhenhua RD., Futian, Shenzhen, China



THIS DRAWING IS UNPUBLISHED. RELEASED FOR PUBLICATION
 © COPYRIGHT BY TYCO ELECTRONICS CORPORATION. ALL INTERNATIONAL RIGHTS RESERVED.

LOC	DIST	REVISIONS					
		P	LTR	DESCRIPTION	DATE	DWN	APVD
G	14		G1	REVISED PER ECR-09-009459	11JUN09	HMR	JR

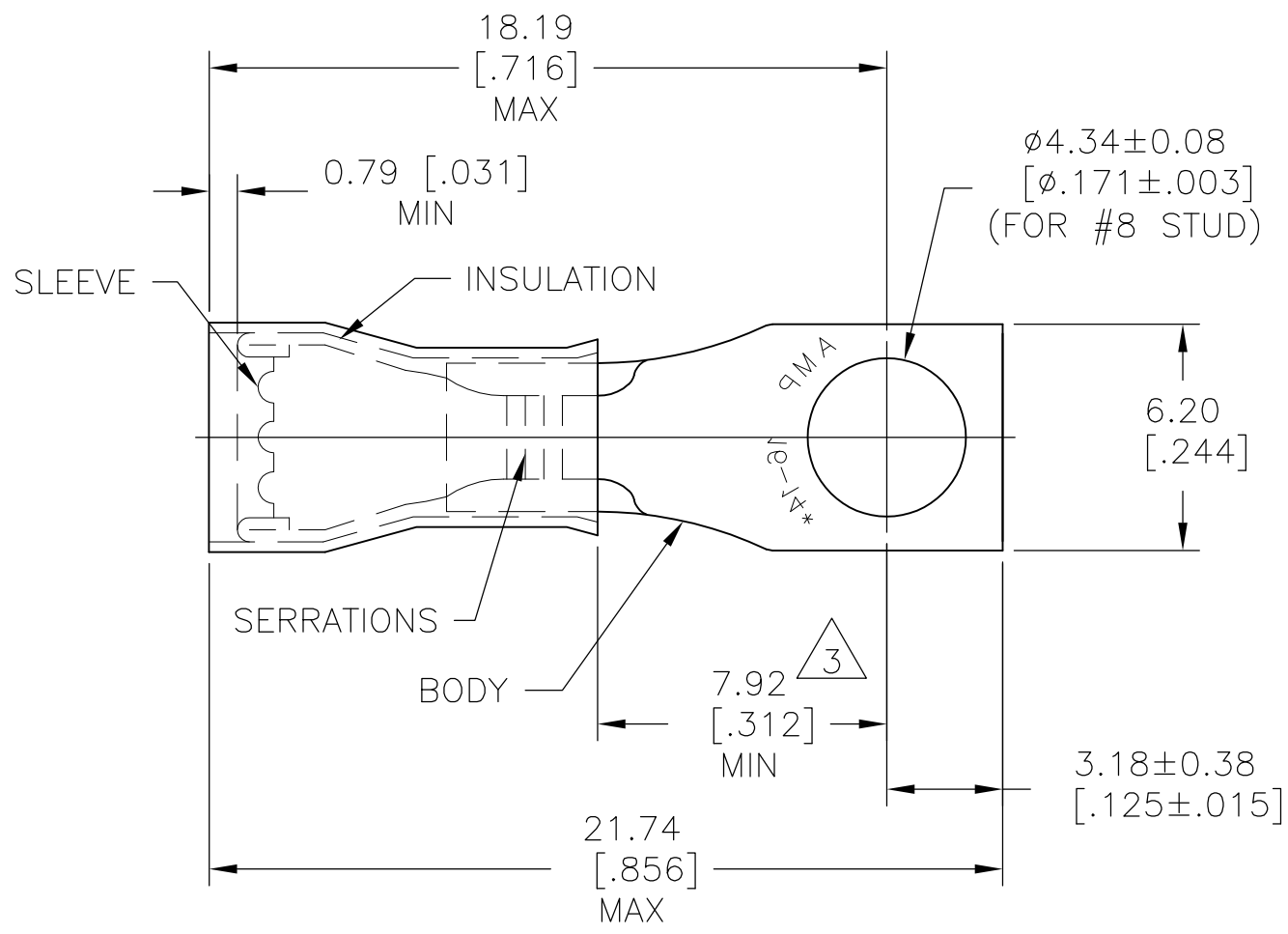

- 1 FOR 2.92[.115] TO 4.32[.170] WIRE INSULATION DIA
- 2 TONGUE MATERIAL THK 0.79±0.05[.031±.002]
- △3 APPLIES FROM EDGE OF METAL BARREL TO CENTERLINE OF STUD HOLE.
- △4 SUPERSEDED BY 35279

QTY	DESCRIPTION	MATERIAL & FINISH	PART NO
1	35279 ON TAPE	INSULATION: NYLON COLOR: BLUE	△4 2-35279-1
1	WIRE TERMINAL	SLEEVE: COPPER ASTM-B152 BODY: COPPER ASTM-B152 TIN PL ASTM-B545	35279

THIS DRAWING IS A CONTROLLED DOCUMENT.		DWN RAGHAVEDRA 11JUN09	Tyco Electronics Corporation Harrisburg, PA 17105-3608	
DIMENSIONS: mm [INCHES]		CHK JEFF RUTH 11JUN09	NAME WIRE TERMINAL PIDG - RECTANGULAR TONGUE WIRE SIZE: 16-14	
TOLERANCES UNLESS OTHERWISE SPECIFIED:		APVD TOM MICHIELUTTI 11JUN09	PRODUCT SPEC -	
0 PLC ± -		APPLICATION SPEC -	SIZE A3	CAGE CODE 00779
1 PLC ± -		WEIGHT -	DRAWING NO G-35279	RESTRICTED TO -
2 PLC ± -		CUSTOMER DRAWING		
3 PLC ± 0.20[.008]		SCALE 5:1		
4 PLC ± -		SHEET 1 OF 1		
ANGLES ± .5°		REV G1		
MATERIAL -	FINISH -			