



Chipsmall Limited consists of a professional team with an average of over 10 year of expertise in the distribution of electronic components. Based in Hongkong, we have already established firm and mutual-benefit business relationships with customers from,Europe,America and south Asia,supplying obsolete and hard-to-find components to meet their specific needs.

With the principle of “Quality Parts,Customers Priority,Honest Operation,and Considerate Service”,our business mainly focus on the distribution of electronic components. Line cards we deal with include Microchip,ALPS,ROHM,Xilinx,Pulse,ON,Everlight and Freescale. Main products comprise IC,Modules,Potentiometer,IC Socket,Relay,Connector.Our parts cover such applications as commercial,industrial, and automotives areas.

We are looking forward to setting up business relationship with you and hope to provide you with the best service and solution. Let us make a better world for our industry!



Contact us

Tel: +86-755-8981 8866 Fax: +86-755-8427 6832

Email & Skype: info@chipsmall.com Web: www.chipsmall.com

Address: A1208, Overseas Decoration Building, #122 Zhenhua RD., Futian, Shenzhen, China





ASSEMBLY

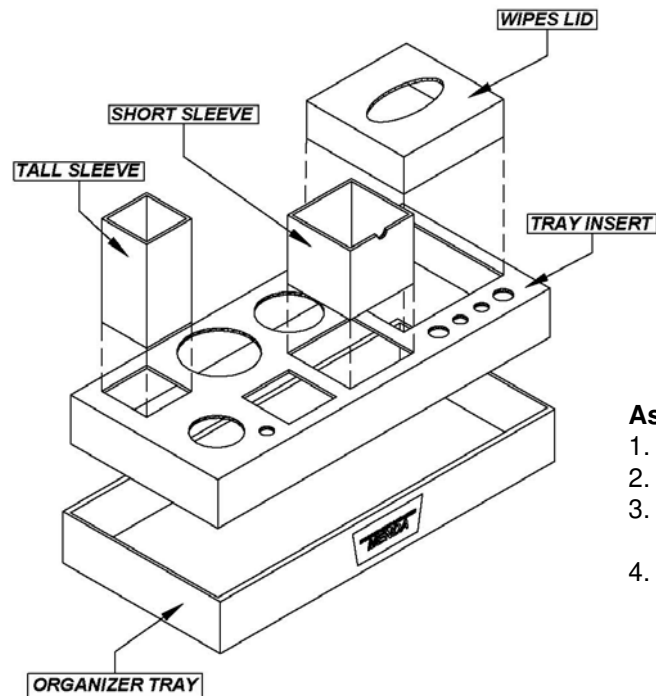

Assembly Instructions:

1. Fold up organizer tray
2. Fold up the insert & place in tray
3. Fold up the short sleeve and tall sleeve and place them into the organizer insert as shown
4. Place overlay label on the front lip of the box.

Description

- Ideal for improving the appearance of the workstation and standardizing the placement of tools at any workstation.
- Can be used for various items which are used on the workstation, such as MENDA dispensing bottles, lotion, flux bottles, solder spools, cutters, tweezers, wash bottles and various other workbench accessories.
- Dimensions: 16-7/8"W x 8-1/8"D x 2-3/8"H
- Made from an Extruded Conductive polypropylene Plastek™ material, making it ideal to properly set up and standardize any ESD workstation.
- Conductive 10E2 – 10E4 ohms per ANSI/ESD S11.11 – material provides reliable path-to-ground
- Superior strength and durability; made from extruded, high impact polypropylene materials
- Chemical and moisture resistant
- Economical alternative to injection molded products
- Made in America

35872	Assembly Workstation Organizer, Kit
35873	Assembly Workstation Organizer, Box Only



Made in America

Call us for your custom needs!

Assembly Workstation Organizer

3651 WALNUT AVE., CHINO, CA 91710
 PHONE: (909) 627-2453 • FAX: (951) 755-8848
 WEBSITE: MendaPump.com

DRAWING NUMBER
35872

DATE:
January 2009

MENDA