



Chipsmall Limited consists of a professional team with an average of over 10 year of expertise in the distribution of electronic components. Based in Hongkong, we have already established firm and mutual-benefit business relationships with customers from,Europe,America and south Asia,supplying obsolete and hard-to-find components to meet their specific needs.

With the principle of “Quality Parts,Customers Priority,Honest Operation,and Considerate Service”,our business mainly focus on the distribution of electronic components. Line cards we deal with include Microchip,ALPS,ROHM,Xilinx,Pulse,ON,Everlight and Freescale. Main products comprise IC,Modules,Potentiometer,IC Socket,Relay,Connector.Our parts cover such applications as commercial,industrial, and automotives areas.

We are looking forward to setting up business relationship with you and hope to provide you with the best service and solution. Let us make a better world for our industry!



Contact us

Tel: +86-755-8981 8866 Fax: +86-755-8427 6832

Email & Skype: info@chipsmall.com Web: www.chipsmall.com

Address: A1208, Overseas Decoration Building, #122 Zhenhua RD., Futian, Shenzhen, China



THIS DRAWING IS UNPUBLISHED. RELEASED FOR PUBLICATION
 © COPYRIGHT BY TYCO ELECTRONICS CORPORATION. ALL INTERNATIONAL RIGHTS RESERVED.

LOC	DIST	REVISIONS			
P	LTR	DESCRIPTION	DATE	DWN	APVD
G	14	N	REV PER ECR 10-000722	25JAN10	JR TM

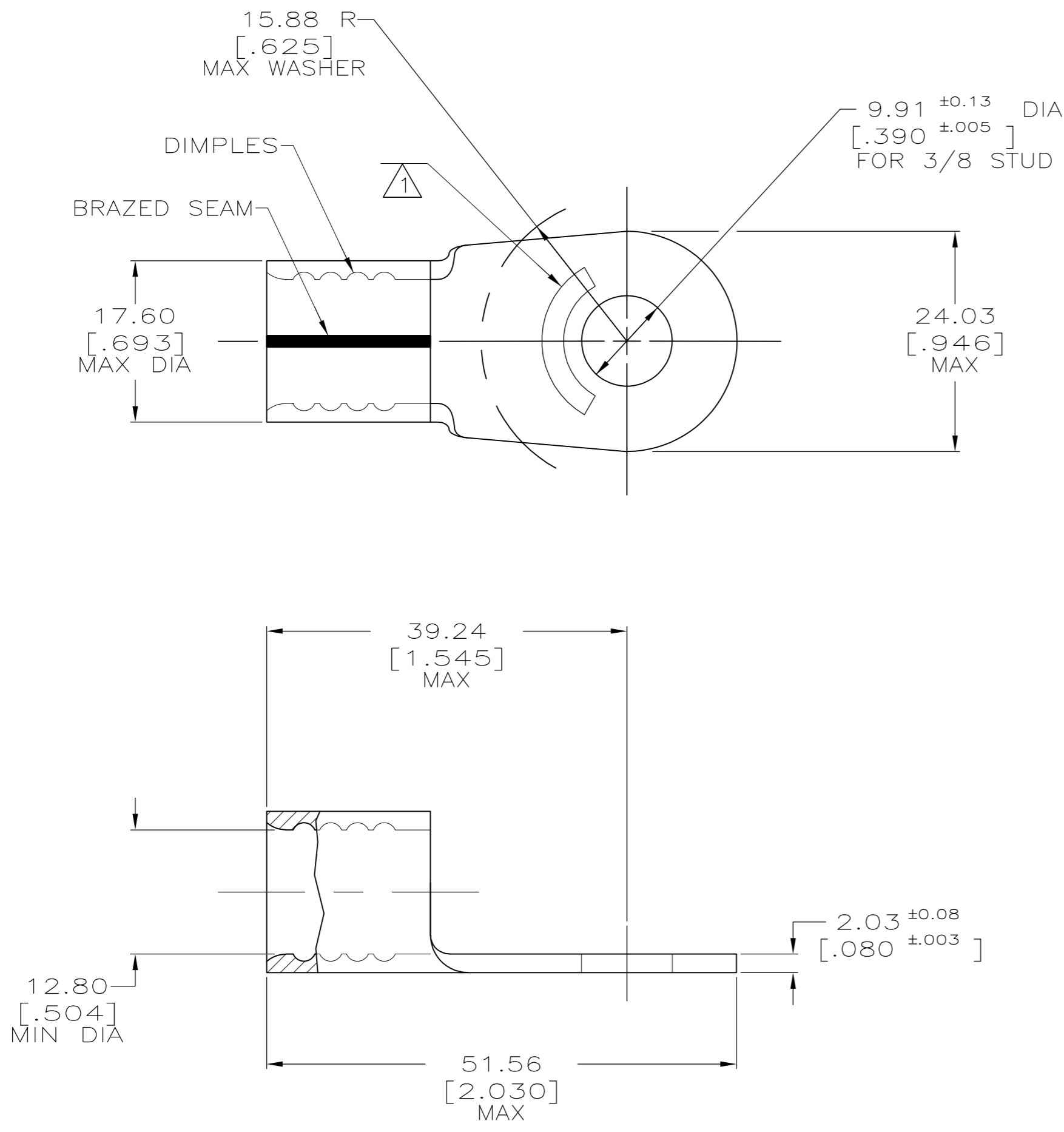

AMP WIRE RANGE	E13288 Listed	LR7189 Certified
2/0 AWG SOLID OR STRANDED	2/0 AWG STRANDED	2/0 AWG SOLID OR STRANDED

- 1 STAMP AMP 2/0W* APPROX AS SHOWN
- 2 COPPER PER ASTM B-152, ANNEALED
- 3 TIN PLATE 0.00254 [.000100] MIN THK EXT. PER ASTM B-545
- 4 MAX RECOMMENDED OPERATING TEMP IS 170°C.
- 5 WIRE CROSS SECTIONAL AREA RANGE: 60.6-76.3mm [119,500-150,500] CMA SOLID OR STRANDED.

25	SMALL PACK	8-36923-3
50	LOOSE PIECE	36923
QTY	PACKAGING TYPE	PART NO.

THIS DRAWING IS A CONTROLLED DOCUMENT.		DWN DK SCHRUM 1/14/94	Tyco Electronics Corporation Harrisburg, PA 17105-3608	
DIMENSIONS: MM [INCHES]		CHK AJ KAUFMAN 1/19/94	NAME	
TOLERANCES UNLESS OTHERWISE SPECIFIED:		APVD JL MECKLEY 1/19/94	TERMINAL, RING TONGUE, SOLISTRAND	
0 PLC ± -		PRODUCT SPEC	SIZE A2	CAGE CODE 00779
1 PLC ± -		APPLICATION SPEC	DRAWING NO C=36923	RESTRICTED TO -
2 PLC ± 0.20[.008]		WEIGHT -	SCALE 2:1	SHEET 1 of 1
3 PLC ± -		CUSTOMER DRAWING	REV N	
4 PLC ± -				
ANGLES ± -				
FINISH				