



Chipsmall Limited consists of a professional team with an average of over 10 year of expertise in the distribution of electronic components. Based in Hongkong, we have already established firm and mutual-benefit business relationships with customers from,Europe,America and south Asia,supplying obsolete and hard-to-find components to meet their specific needs.

With the principle of “Quality Parts,Customers Priority,Honest Operation,and Considerate Service”,our business mainly focus on the distribution of electronic components. Line cards we deal with include Microchip,ALPS,ROHM,Xilinx,Pulse,ON,Everlight and Freescale. Main products comprise IC,Modules,Potentiometer,IC Socket,Relay,Connector.Our parts cover such applications as commercial,industrial, and automotives areas.

We are looking forward to setting up business relationship with you and hope to provide you with the best service and solution. Let us make a better world for our industry!



Contact us

Tel: +86-755-8981 8866 Fax: +86-755-8427 6832

Email & Skype: info@chipsmall.com Web: www.chipsmall.com

Address: A1208, Overseas Decoration Building, #122 Zhenhua RD., Futian, Shenzhen, China



4

3

2

1

THIS DRAWING IS UNPUBLISHED. RELEASED FOR PUBLICATION ,19 .
 © COPYRIGHT 19 BY AMP INCORPORATED. ALL RIGHTS RESERVED.

LOC	DIST	REVISIONS			
P	LTR	DESCRIPTION	DATE	DWN	APVD
G	14	D	REVISED PER 0L20-0163-97	08AUG97	DKS MJS

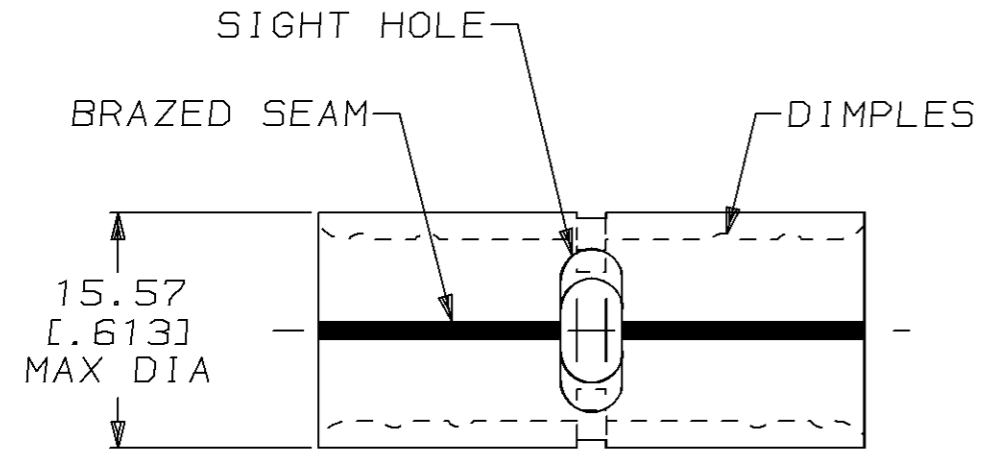

AMP WIRE RANGE	E13288 Listed
1/0 AWG SOLID OR STRANDED	1/0 AWG SOLID OR STRANDED
LR7189 Certified	MILITARY P/N AND CLASS
1/0 AWG SOLID OR STRANDED	NOT APPLICABLE

△ STAMP AMP 1/0W* 100 APPROX AS SHOWN

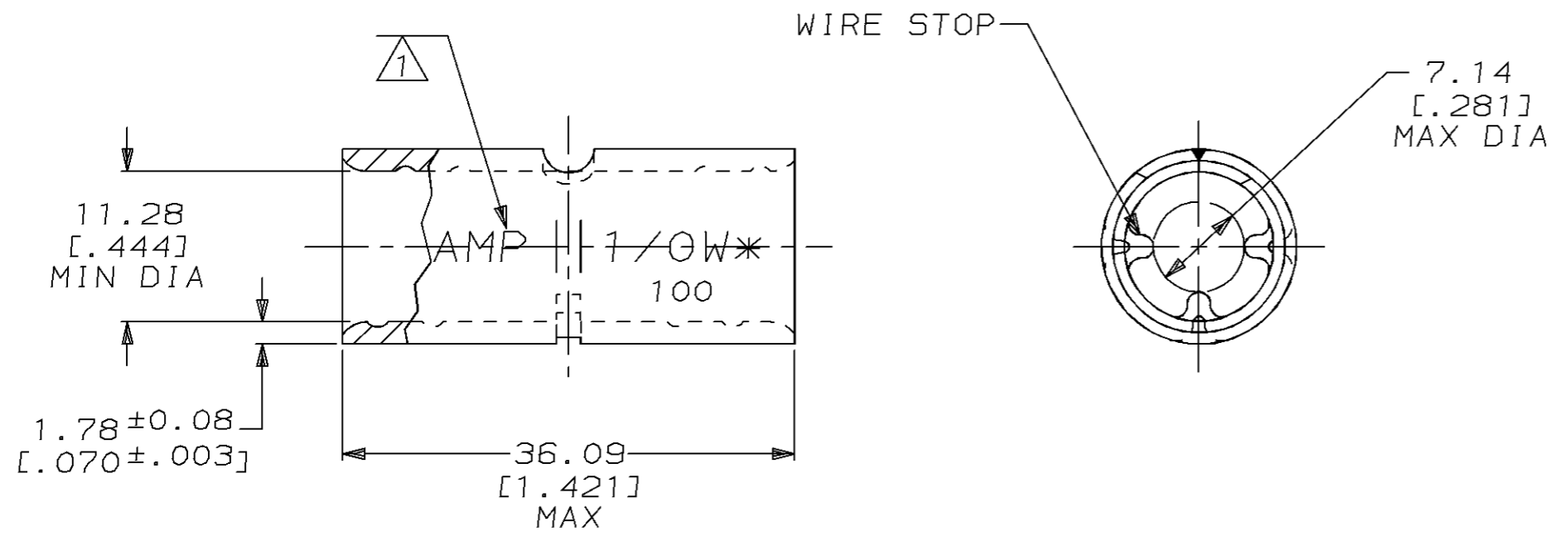

5	LOOSE PIECE, BAG	8-36957-5
25	LOOSE PIECE, BOX	8-36957-3
-	LOOSE PIECE	36957
QTY	PACKAGE TYPE	AMP PART NUMBER

AMP INCORPORATED
CUSTOMER SERVICE SYSTEMS

FOR ADDITIONAL PRODUCT INFORMATION OR COPIES OF DRAWINGS AND TECHNICAL DOCUMENTS	PRODUCT INFORMATION CENTER 1-800-522-6752	RECOMMENDED OPERATING TEMPERATURE: 170°C MAX
FOR APPLICATION TOOLING INFORMATION	TOOLING ASSISTANCE CENTER 1-800-722-1111	VOLTAGE RATING: NOT APPLICABLE
FOR ORDER ENTRY	1-800-526-5142	WIRE CROSS SECTIONAL AREA RANGE: 42.2-60.0mm ² [83,700-119,500] CIR MILS SOLID OR STRANDED

THIS DRAWING IS A CONTROLLED DOCUMENT FOR AMP INCORPORATED. IT IS SUBJECT TO CHANGE AND THE CONTROLLING ENGINEERING ORGANIZATION SHOULD BE CONTACTED FOR THE LATEST REVISION.

DIMENSIONS: mm [INCHES]	TOLERANCES UNLESS OTHERWISE SPECIFIED:
	0 PLC ±-
	1 PLC ±-
	2 PLC ±0.20 [.008]
	3 PLC ±-
	4 PLC ±-
	ANGLES ±-
MATERIAL COPPER PER ASTM B-152 ANNEALED	FINISH TIN PLATE 0.00254 [.000100] MIN THK PER MIL-T-10727

DWN DK SCHRUM 08AUG97	AMP AMP Incorporated Harrisburg, PA 17105-3608
CHK MJ SPICER 11AUG97	
APVD JL MECKLEY 11AUG97	
PRODUCT SPEC APPLICATION SPEC WEIGHT	
NAME SPLICE, BUTT, SOLISTRAND™	SIZE A3
CAGE CODE 00779	DRAWING NO C-36957
CUSTOMER DRAWING	SCALE 2:1
	SHEET 1 OF 1
	REV D