



Chipsmall Limited consists of a professional team with an average of over 10 year of expertise in the distribution of electronic components. Based in Hongkong, we have already established firm and mutual-benefit business relationships with customers from,Europe,America and south Asia,supplying obsolete and hard-to-find components to meet their specific needs.

With the principle of “Quality Parts,Customers Priority,Honest Operation,and Considerate Service”,our business mainly focus on the distribution of electronic components. Line cards we deal with include Microchip,ALPS,ROHM,Xilinx,Pulse,ON,Everlight and Freescale. Main products comprise IC,Modules,Potentiometer,IC Socket,Relay,Connector.Our parts cover such applications as commercial,industrial, and automotives areas.

We are looking forward to setting up business relationship with you and hope to provide you with the best service and solution. Let us make a better world for our industry!



Contact us

Tel: +86-755-8981 8866 Fax: +86-755-8427 6832

Email & Skype: info@chipsmall.com Web: www.chipsmall.com

Address: A1208, Overseas Decoration Building, #122 Zhenhua RD., Futian, Shenzhen, China



150W LED Driver

Indoor & Outdoor Magnetic Dimmable LED Driver

Product Code: M150L12DC-AR

iLED SKU#: 3749

Magnitude's M150L12DC-AR is the most compact LED driver on the market with a magnetic transformer core. It is equipped with two auto-reset breakers, one on the input and one on the output to protect both the load and driver. The driver is encased in a coated metal box that includes two knock-outs on the bottom for easy installation which complies with electrical code requirements.

Features

Dimmable with standard MLV/TRIAC (leading edge) dimmer switch
Dual protection-primary and secondary auto-reset circuit breakers
Nema 3R Enclosure- Outdoor Use

Two bottom knock-outs

ETL Listed, Certified to CSA Standard

Specifications

50% Load is required if not being used with a dimmer.

Max Load	150W
Input Voltage	120V AC
Input Current at Max Load	1.95 A
Output Voltage	12V DC
Output Current at Max Load	13.3 A
Open Circuit Output Voltage	13.3V DC
Avg. Efficiency	80%
Power Factor on I	0.93
Coil Former	Double Section Bobbin
Max Ambient Temperature	-30°C to 45°C
Min Installation Space btw Drivers	5 inches
Thermal Class	B130°C
Leads Primary	PVC 600V #18
Leads Secondary	PVC 300V #12
Dimensions (inch)	9.8" x 3" x 3"
Weight	87 oz.

Wiring Diagram

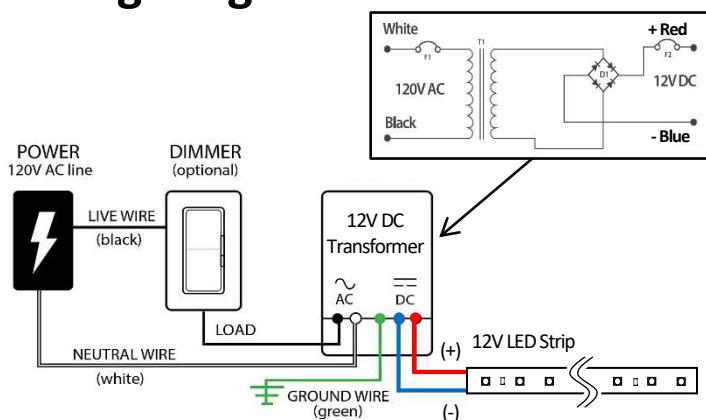

BEFORE YOU BEGIN

Note: This dimmable transformer requires a **compatible magnetic low voltage (MLV) wall dimmer** for proper operation. See the list of approved dimmers recommended by Magnitude Inc. and Inspired LED. Driver must be installed in a well-ventilated area free from explosive gasses and vapors. Proper operation requires a free flow of air. Driver should be installed by a qualified electrician in accordance with article 450 of the National Electrical Code.

Precautions Before Installing

Check the label to ensure the driver has the proper input voltage and wattage for the job. Check the wire markings to ensure they match the wiring diagram below.

Input Connections/Grounding

Remove the wiring compartment knockouts and install the clamp connectors provided with the driver. With power turned off, route the input wires through the clamp connector and connect one wire to black and one wire to white. For all wire connections use only UL listed wire nuts and connectors of suitable size and style. Connect the ground wire to the driver green wire, **the driver case MUST be grounded in accordance with N.E.C.**

Output Connections

Bring the wires of the light fixture through the other clamp connector and connect them to the driver wire- positive to the **red (+)** wire and negative to the **blue (-)** wire.

Mounting

Select a location capable of supporting the weight of the driver. Use the two keyholes in in the driver case to mount using suitable screws. It is recommended that the driver be mounted vertically with the wiring compartment pointing down.

Output Voltage vs. Load

