



Chipsmall Limited consists of a professional team with an average of over 10 year of expertise in the distribution of electronic components. Based in Hongkong, we have already established firm and mutual-benefit business relationships with customers from,Europe,America and south Asia,supplying obsolete and hard-to-find components to meet their specific needs.

With the principle of “Quality Parts,Customers Priority,Honest Operation,and Considerate Service”,our business mainly focus on the distribution of electronic components. Line cards we deal with include Microchip,ALPS,ROHM,Xilinx,Pulse,ON,Everlight and Freescale. Main products comprise IC,Modules,Potentiometer,IC Socket,Relay,Connector.Our parts cover such applications as commercial,industrial, and automotives areas.

We are looking forward to setting up business relationship with you and hope to provide you with the best service and solution. Let us make a better world for our industry!



## Contact us

Tel: +86-755-8981 8866 Fax: +86-755-8427 6832

Email & Skype: info@chipsmall.com Web: www.chipsmall.com

Address: A1208, Overseas Decoration Building, #122 Zhenhua RD., Futian, Shenzhen, China



ENERGIZER 377/376

**ZEROMERCURY**

**SILVER OXIDE**



**Industry Standard Dimensions**

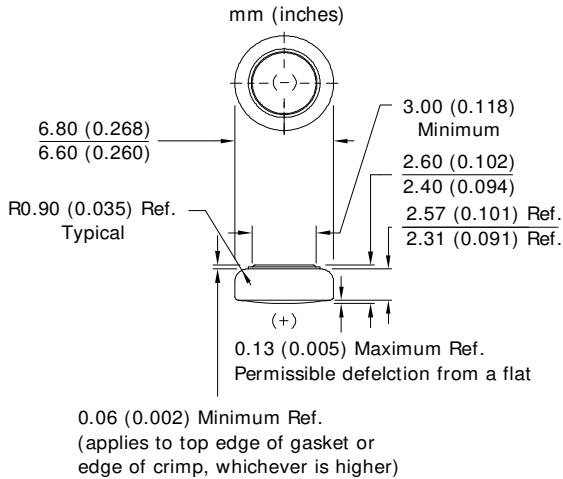

DESIGNED FOR USE ON CONTINUOUS LOW DRAIN  
HIGH PULSE ON DEMAND

**Specifications**

- Chemical System:** Silver Oxide (Zn/Ag<sub>2</sub>O)
- Designation:** ANSI/NEDA-1176SO, IEC-SR66
- Nominal Voltage:** 1.55 Volts
- Typical Capacity:** 24 mAh\* (to 1.2 volts)
- Capacity Test:** 47K ohm continuous drain at 21°C
- Typical Weight:** 0.42 grams (0.015 oz.)
- Typical Volume:** 0.09 cubic centimeters (0.0063 cubic inch)
- Impedance (40 Hz):** 15 to 30 ohms

\* Varies according to the applied load, temperature, and cutoff voltage.

**Cross Section**

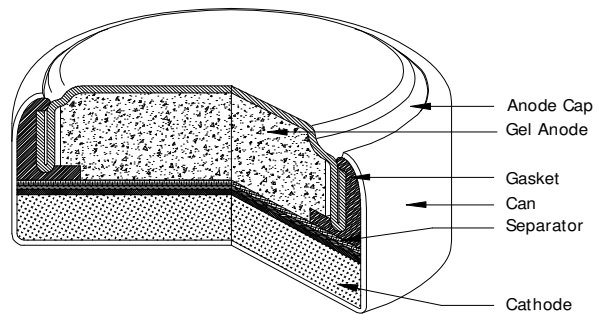

**Typical Discharge Characteristics**

Typical Performance at 21°C (70°F)

**Schedule:** Continuous  
**Typical Drain @1.46V:**  
0.031 milliamperes  
**Load:** 47K ohm

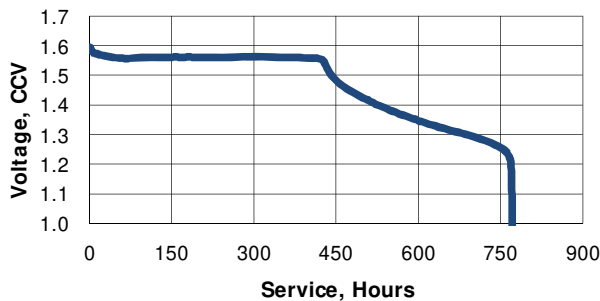

<u>Schedule</u>	<u>Typical Drains</u> at 1.46V (milliamperes)	<u>Load</u> (ohm)	<u>Cutoff</u> 1.2V (hours)
Continuous	0.031	47K	773

**Temperature Characteristics**

Typical Performance at Low Discharge Rates

**Service Effects**

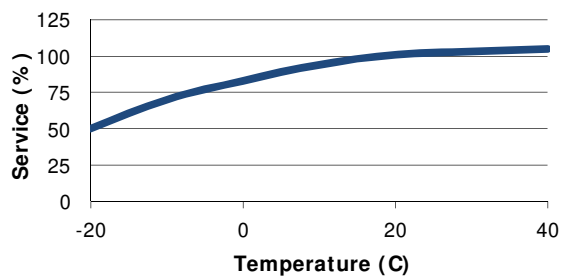

**Storage Effects**

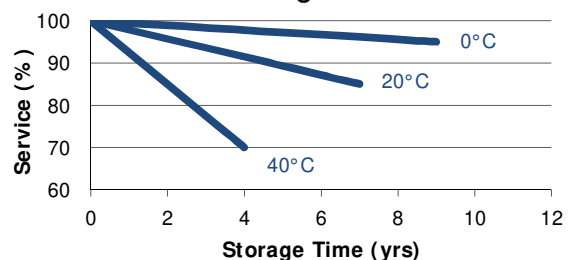

**Important Notice**

This datasheet contains typical information specific to products manufactured at the time of its publication.

© Energizer Holdings, Inc. - Contents herein do not constitute a warranty.