



Chipsmall Limited consists of a professional team with an average of over 10 year of expertise in the distribution of electronic components. Based in Hongkong, we have already established firm and mutual-benefit business relationships with customers from,Europe,America and south Asia,supplying obsolete and hard-to-find components to meet their specific needs.

With the principle of “Quality Parts,Customers Priority,Honest Operation,and Considerate Service”,our business mainly focus on the distribution of electronic components. Line cards we deal with include Microchip,ALPS,ROHM,Xilinx,Pulse,ON,Everlight and Freescale. Main products comprise IC,Modules,Potentiometer,IC Socket,Relay,Connector.Our parts cover such applications as commercial,industrial, and automotives areas.

We are looking forward to setting up business relationship with you and hope to provide you with the best service and solution. Let us make a better world for our industry!



Contact us

Tel: +86-755-8981 8866 Fax: +86-755-8427 6832

Email & Skype: info@chipsmall.com Web: www.chipsmall.com

Address: A1208, Overseas Decoration Building, #122 Zhenhua RD., Futian, Shenzhen, China



One Phase Power Distribution Block

- Quick mounting and wiring
- IP20 Finger Safe
- DIN Rail or Panel Mount
- Blocks fit with other DIN Rail mountable modular devices (height 95mm, depth 44.5mm)
- Accessories increase the number of outputs with only one input (applies **only** to 38041 and 38032)
- No caps to open / remove
- Material
Housing: Polyamide
Metal Body: Brass



Part Number:	DB16*		38049		DB35*		38041	
Approvals	UL File E220514		UL File E98082		UL File E220514		UL File E98082	
Current Rating	80A	80A	80A	80A	115A	125A	115A	125A
Voltage Rating	600V AC	690V AC	600V AC	690V AC	600V AC	690V AC	600V AC	690V AC
SCCR	10kA		100kA		10kA		100kA	
No. of Inputs	1	1	1	1	1	1	1	1
Wire Range	8-4 AWG	6-16mm ²	8-4 AWG	6-16mm ²	8-2 AWG	10-35mm ²	8-2 AWG	10-35mm ²
Torque	13.5lb.-in.	1.5Nm	13.5lb.-in.	1.5Nm	31lb.-in.	3.5Nm	13.5lb.-in.	3.5Nm
Screw Type	Pozi Drive 2		Pozi Drive 2		Pozi Drive 2		Pozi Drive 2	
No. of Outputs	6	6	6	6	6	6	6	6
Wire Range	(2x)8-4 AWG	(2x)6-16mm ²	(2x)8-4 AWG	(2x)6-16mm ²	14-6 AWG	2.5-16mm ²	14-6 AWG	2.5-16mm ²
Torque	13.5lb.-in.	1.5Nm	13.5lb.-in.	1.5Nm	17.5lb.-in.	2Nm	17.5lb.-in.	2Nm
Wire Range	(4x)14-10 AWG	(4x)2.5-6mm ²	(4x)14-10 AWG	(4x)2.5-6mm ²				
Torque	7.2lb.-in.	0.8Nm	7.2lb.-in.	0.8Nm				
Screw Type	Pozi Drive 2		Pozi Drive 2		Pozi Drive 2		Pozi Drive 2	

Optional Marking Tag
** (for DB16 and DB35)

Dimensions:

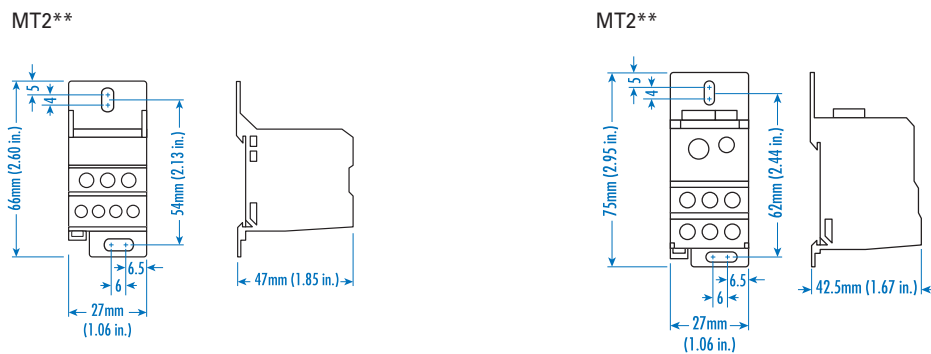

* Available in colors.

COLOR BLOCKS
(other than grey standard)

When ordering please add color suffix to Cat. No.

Example: CTS2.5U-N/R

Color	Ordering Suffix
Red	R
Blue	BU
Black	BL
Orange	O
Green	G
Yellow	Y
White	W
Beige	BG
Dark Brown	DB

38041

Fork Type Busbar 38045

38041

Accessories: Fork Type Busbar
Part No: **38045** to jump 2 Blocks
38046 to jump 8 Blocks
can be cut

38076

38032

38074



CE

CE

CE

Part Number:	38076		38032		38074	
Approvals	UL File E98082		UL File E98082	C US		UL File E98082
Current Rating	115A	125A	160A	160A	175A	175A
Voltage Rating	600V AC	690V AC	600V AC	690V AC	600V AC	690V AC
SCCR	100kA		100kA		100kA	
No. of Inputs	1	1	1	1	1	1
Wire Range	8-2 AWG	10-35mm ²	8-2/0AWG	10-70mm ²	6-2/0AWG	16-70mm ²
Torque	53lb.-in.	6Nm	35.5lb.-in.	4Nm	53lb.-in.	6Nm
Screw Type	Hex 4		Hex 5		Hex 5	
No. of Outputs	10	10	6	6	10	10
Wire Range	14-4 AWG	2.5-16mm ²	14-6 AWG	2.5-16mm ²	14-4 AWG	2.5-16mm ²
Torque	26.5lb.-in.	3Nm	17.5lb.-in.	2Nm	26.5lb.-in.	3Nm
Screw Type	Hex 3		Hex 3		Hex 3	

Dimensions:

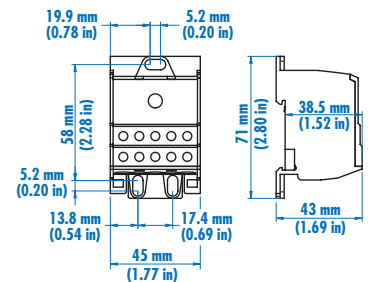
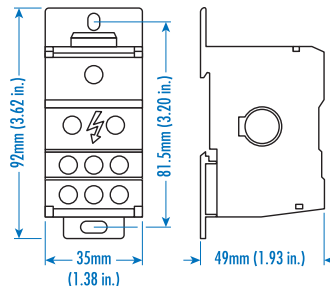
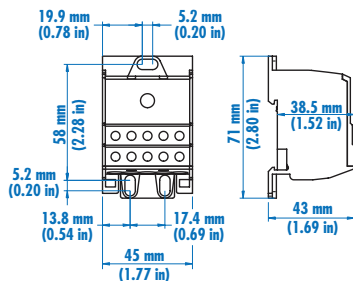

38032

Accessories: Copper Jumper Bar (6x15 mm)
 Part No: **3803221** for 2 Blocks
3803231 for 3 Blocks
3803241 for 4 Blocks
 can be cut

One Phase Power Distribution Block

- Quick mounting and wiring
- IP20 Finger Safe
- DIN Rail or Panel Mount
- Blocks fit with other DIN Rail mountable modular devices (height 95mm, depth 44.5mm)
- Accessories increase the number of outputs with only one input.
- No caps to open or remove
- Material
 - Housing: Polyamide
 - Metal Body: Brass



Part Number:	38020		38019			
Approvals	UL File E98082	C US		UL File E98082	C US	
Current Rating	230A	250A	310A	400A		
Voltage Rating	600V AC	690V AC	600V AC	690V AC		
SCCR		100kA		100kA		
No. of Inputs	1	1	1	1		
Wire Range	2-4/0AWG	35-120mm ²	3/0-350mcm	95-185mm ²		
Torque	170lb.-in.	19Nm	230lb.-in.	25Nm		
Screw Type	Hex 6		Hex 8			
No. of Outputs	11	11	11	11		
Wire Range	(2x) 14-2AWG	(2x) 2.5-35mm ²	(2x) 14-2AWG	(2x) 2.5-35mm ²		
Torque	31lb.-in.	3.5Nm	31lb.-in.	3.5Nm		
Wire Range	(5x) 14-6AWG	(5x) 2.5-16mm ²	(5x) 14-6AWG	(5x) 2.5-16mm ²		
Torque	17.5lb.-in.	2Nm	17.5lb.-in.	2Nm		
Wire Range	(4x) 14-8AWG	(4x) 2.5-10mm ²	(4x) 14-8AWG	(4x) 2.5-10mm ²		
Torque	17.5lb.-in.	2Nm	17.5lb.-in.	2Nm		
Screw Type	standard screwdriver		standard screwdriver			

Dimensions:

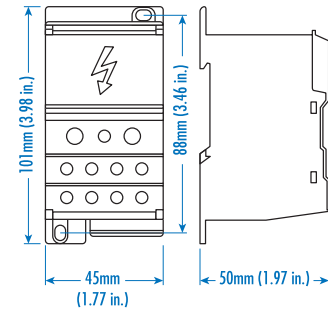
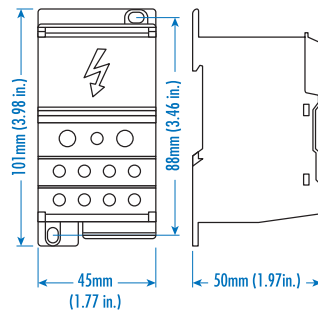

- Quick mounting and wiring
- IP20 Finger Safe
- DIN Rail or Panel Mount
- Blocks fit with other DIN Rail mountable modular devices
- Same compact size for both ratings
- No caps to open or remove
- Material
 - Housing: Polyamide
 - Metal Body: Brass

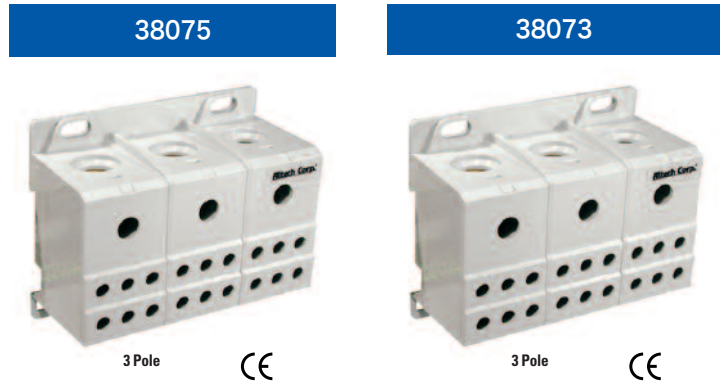

Part Number:	38075		38073	
Approvals	UL File E98082		UL File E98082	
Current Rating	115A	115A	175A	175A
Voltage Rating	600V AC	690V AC	600V AC	690V AC
SCCR	100kA		100kA	
No. of Inputs	3x1	3x1	3x1	3x1
Wire Range	8-2AWG	10-35mm ²	8-2/0AWG	10-70mm ²
Torque	31lb.-in.	3.5Nm	35.5lb.-in.	4Nm
Screw Type	Hex 4		Hex 5	
No. of Outputs	3x6	3x6	3x6	3x6
Wire Range	14-4AWG	2.5-16mm ²	14-4AWG	2.5-16mm ²
Torque	17.5lb.-in.	2Nm	17.5 lb.-in.	2Nm
Screw Type	Hex 3		Hex 3	

Dimensions:

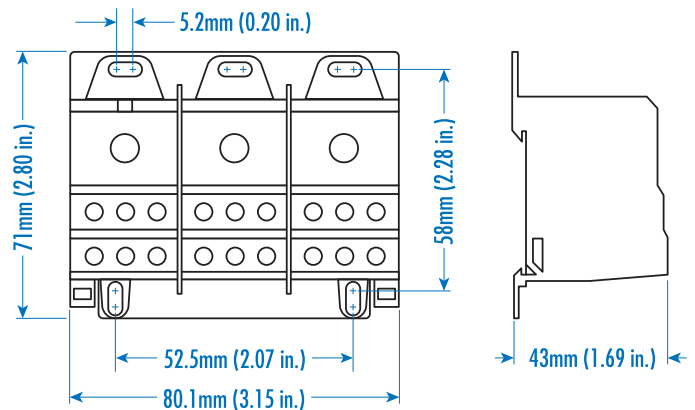

Splicer Blocks

- Quick mounting and wiring
- IP20 Finger Safe
- DIN Rail or Panel Mount
- No caps to open or remove
- Material

Housing: Polyamide
Metal Body: Aluminum

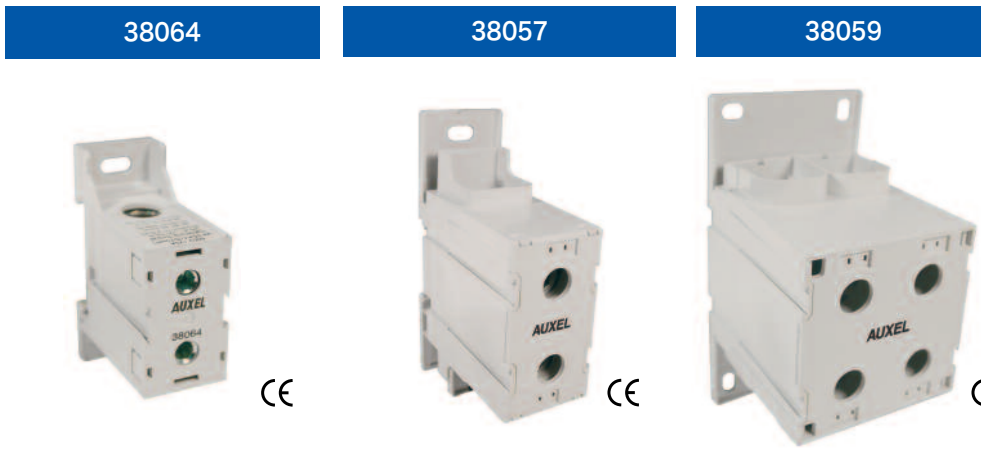

Part Number:	38064		38057		38059	
Approvals	UL File E98082		UL File E98082		UL File E98082	
Current Rating	175A	175A	335A	400A	840A	800A
Voltage Rating	600V AC	690V AC	600V AC	690V AC	600V AC	690V AC
No. of Inputs	1	1	1	1	2	2
Wire Range	14-1AWG	2.5mm ² -50mm ²	6AWG-400MCM	16mm ² -185mm ²	3AWG-600MCM	25-300mm ²
Torque	106.2lb.-in.	12Nm	221lb.-in.	25Nm	310lb.-in.	35Nm
Screw Type	Hex 5		Hex 10		Hex 10	
No. of Outputs	1	1	1	1	2	2
Wire Range	14-1AWG	2.5mm ² -50mm ²	6AWG-400MCM	16mm ² -185mm ²	3AWG-600MCM	25-300mm ²
Torque	106.2lb.-in.	12Nm	221lb.-in.	25Nm	310lb.-in.	35Nm
Screw Type	Hex 5		Hex 10		Hex 10	

Dimensions:

