



Chipsmall Limited consists of a professional team with an average of over 10 year of expertise in the distribution of electronic components. Based in Hongkong, we have already established firm and mutual-benefit business relationships with customers from,Europe,America and south Asia,supplying obsolete and hard-to-find components to meet their specific needs.

With the principle of “Quality Parts,Customers Priority,Honest Operation,and Considerate Service”,our business mainly focus on the distribution of electronic components. Line cards we deal with include Microchip,ALPS,ROHM,Xilinx,Pulse,ON,Everlight and Freescale. Main products comprise IC,Modules,Potentiometer,IC Socket,Relay,Connector.Our parts cover such applications as commercial,industrial, and automotives areas.

We are looking forward to setting up business relationship with you and hope to provide you with the best service and solution. Let us make a better world for our industry!



Contact us

Tel: +86-755-8981 8866 Fax: +86-755-8427 6832

Email & Skype: info@chipsmall.com Web: www.chipsmall.com

Address: A1208, Overseas Decoration Building, #122 Zhenhua RD., Futian, Shenzhen, China



VICOR CONFIDENTIAL
 THIS DOCUMENT AND THE DATA DISCLOSED HEREIN OR
 HEREIN IS NOT TO BE REPRODUCED, USED OR
 DISCLOSED IN ANY MANNER OR IN PART TO ANYONE WITHOUT
 THE PERMISSION OF VICOR CORP.

REV.	DESCRIPTION	DATE	APPROVED
1	RELEASED PER E120943	GCK 10/22/12	REJH
2	REVISED PER E130143	GCK 02/01/13	REJH

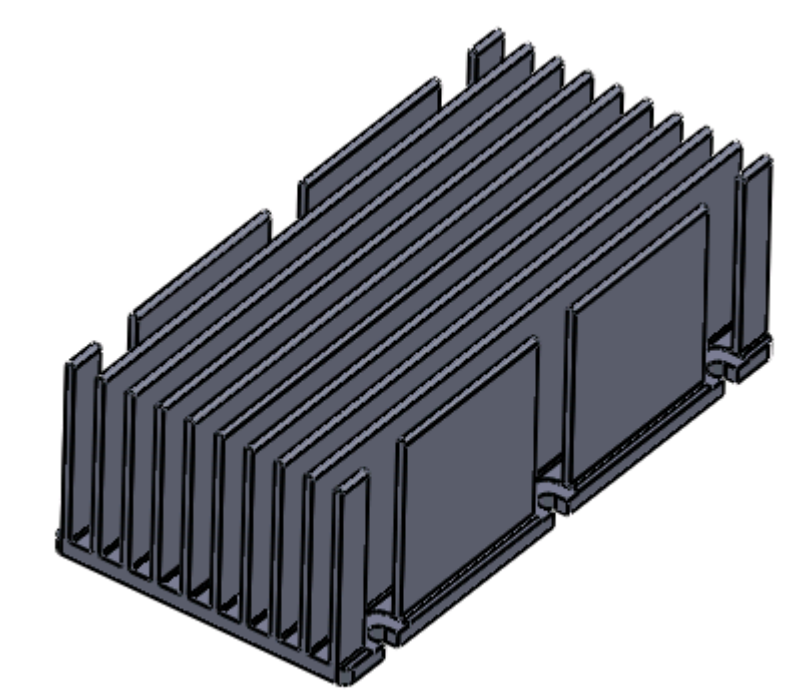
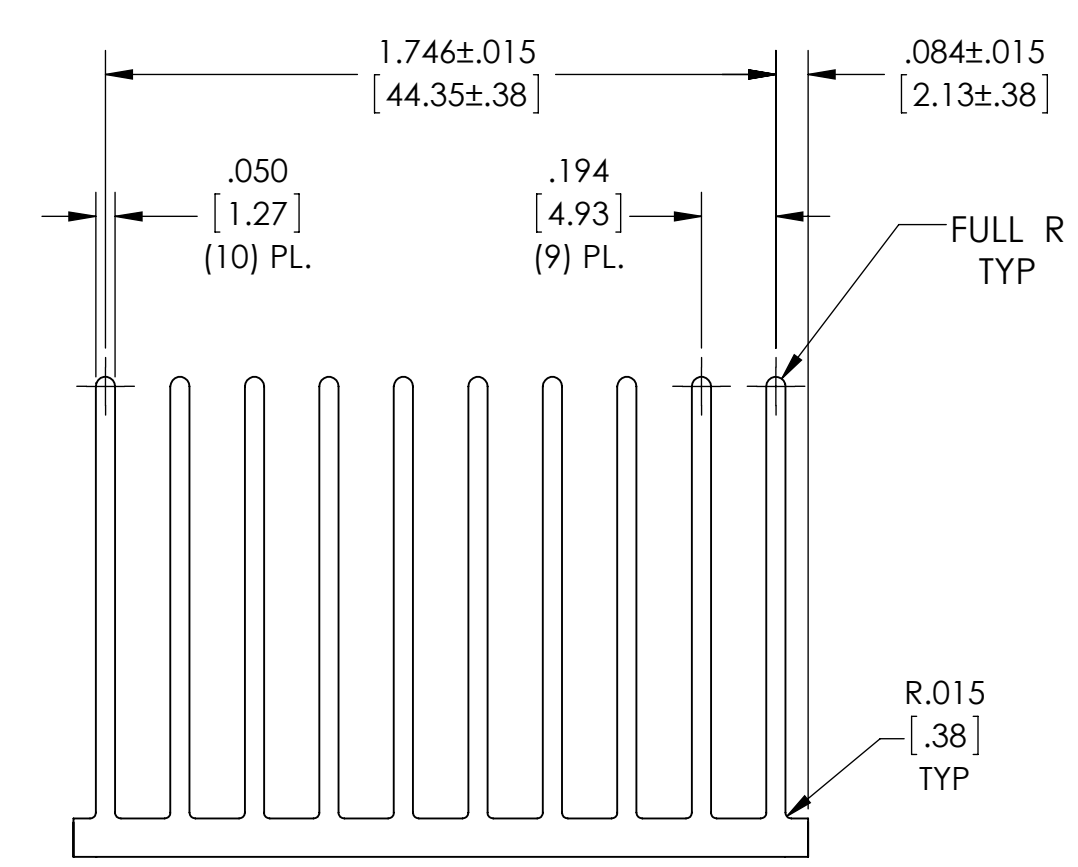
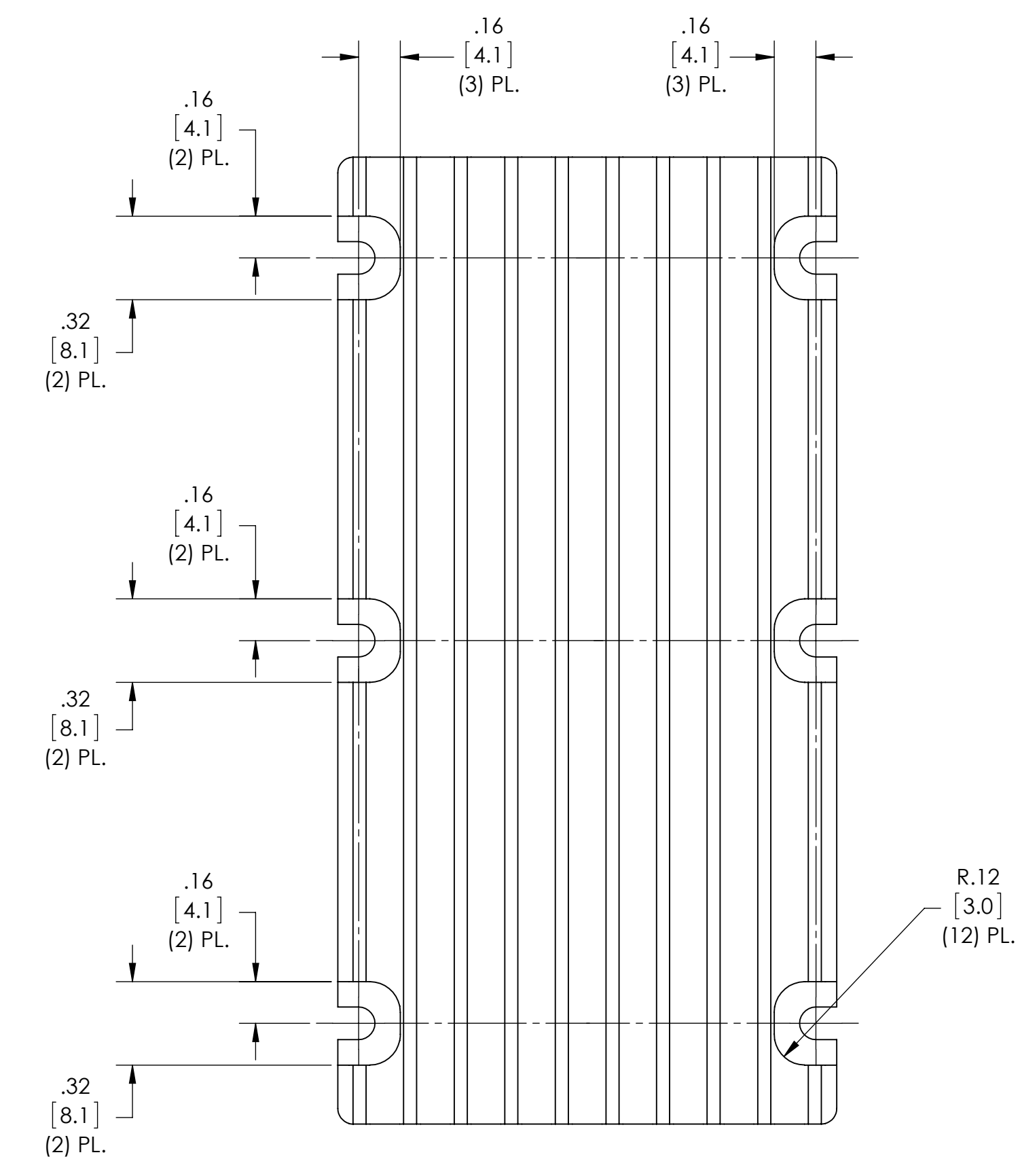
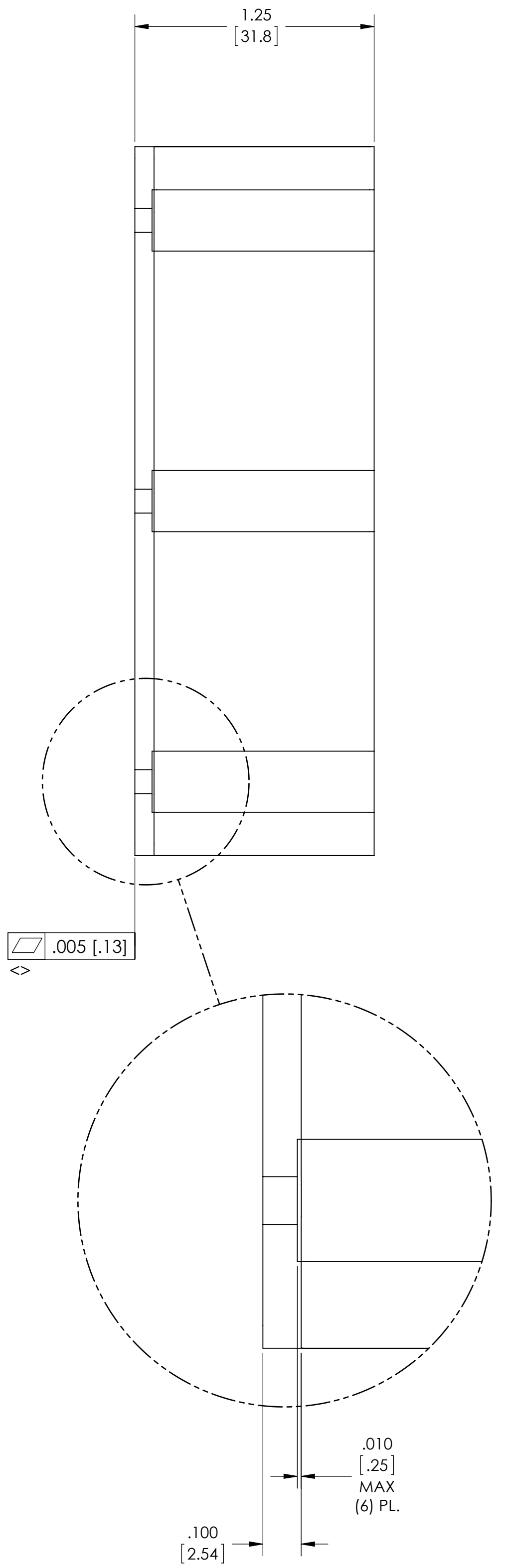
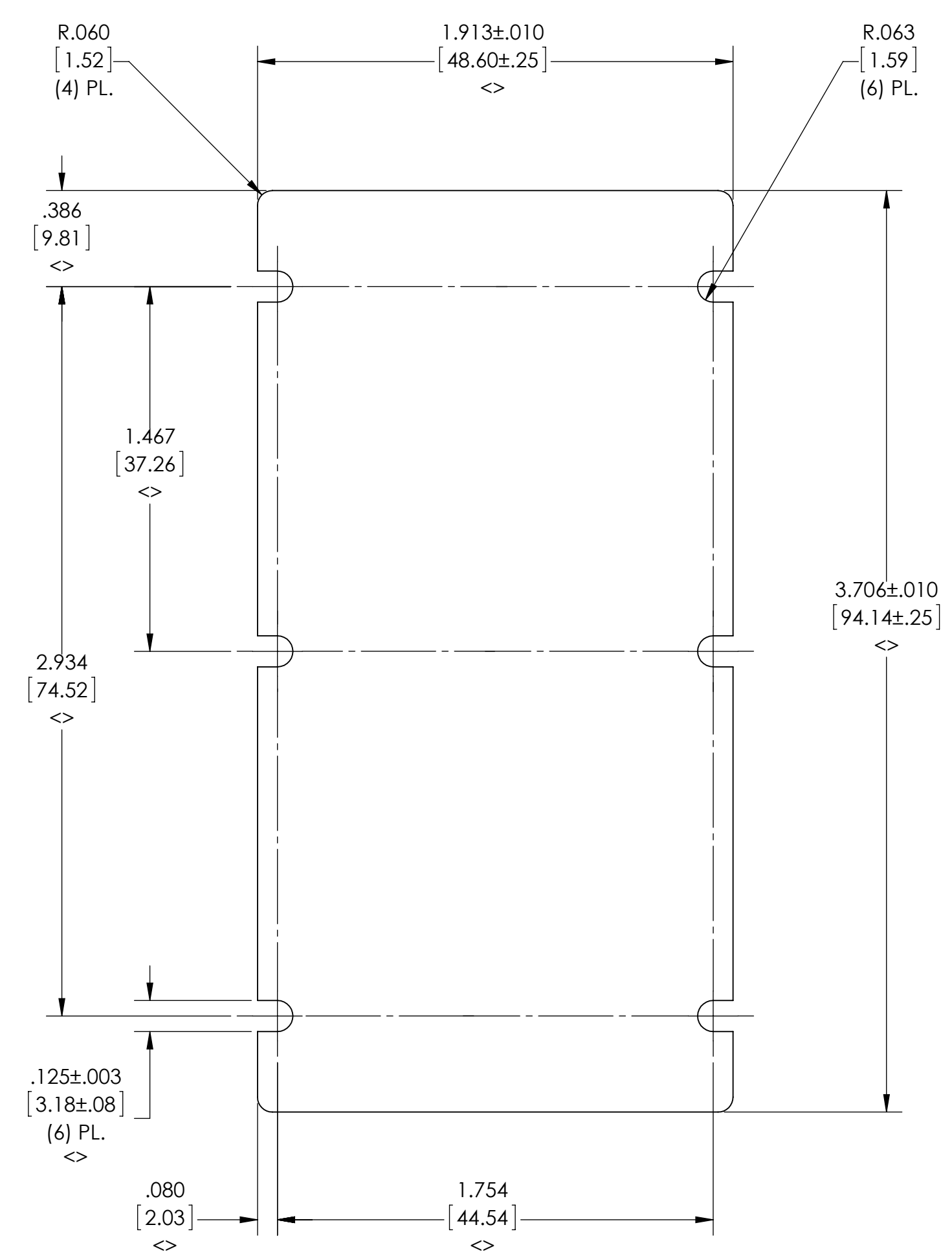

- NOTES:
- 1- MATL: ALUMINUM 6063-T5.
 - 2- CORNERS SHOWN SHARP TO BE .005/[.13] MAX.
 - 3- CLEAR FINISH, RoHS COMPLIANT PER CST-0001, LATEST REVISION PER
 A.) CHROMIUM FREE, OR
 B.) TRIVALENT CHROMIUM IN ACCORDANCE WITH MIL-DTL-5541, TYPE II, CLASS 1A OR 3.
 SEE CST-0003 FOR TYPES OF AVAILABLE FINISHES.
 - 4- ALL DIMENSIONS APPLY AFTER PLATING.
 - 5- <> DENOTES CRITICAL CHARACTERISTIC FOR LOT INSPECTION.
 - 6- MAXIMUM STEP BETWEEN ADJOINING CUTTER PASSES TO BE .0005/[.013]
 - 7- BASE PLATE SURFACE PREPARATION PRIOR TO CLEAR FINISH IN ACCORDANCE WITH WS-0016.
 - 8- REMOVE ALL BURRS AND SHARPE EDGES.

DRAWN BY R.E.J Hickey	DATE 12/15/11	VICOR SWD	
UNLESS OTHERWISE SPECIFIED DIMENSIONS ARE: INCH / [MM]		HEATSINK VIBrick L-FLOW 1.25	
TOLERANCES ARE: DECIMALS XXX [X.X] = +0.01 [0.25] X.XXX [X.XX] = ±0.005 [0.127]	ANGLES ±1°	SIZE D	CAGE CODE 67131
THIRD ANGLE PROJECTION 	SCALE 2:1	DWG NO 38145	REV 2
DO NOT SCALE DRAWING		SHEET 1 OF 1	