



Chipsmall Limited consists of a professional team with an average of over 10 year of expertise in the distribution of electronic components. Based in Hongkong, we have already established firm and mutual-benefit business relationships with customers from,Europe,America and south Asia,supplying obsolete and hard-to-find components to meet their specific needs.

With the principle of “Quality Parts,Customers Priority,Honest Operation,and Considerate Service”,our business mainly focus on the distribution of electronic components. Line cards we deal with include Microchip,ALPS,ROHM,Xilinx,Pulse,ON,Everlight and Freescale. Main products comprise IC,Modules,Potentiometer,IC Socket,Relay,Connector.Our parts cover such applications as commercial,industrial, and automotives areas.

We are looking forward to setting up business relationship with you and hope to provide you with the best service and solution. Let us make a better world for our industry!



Contact us

Tel: +86-755-8981 8866 Fax: +86-755-8427 6832

Email & Skype: info@chipsmall.com Web: www.chipsmall.com

Address: A1208, Overseas Decoration Building, #122 Zhenhua RD., Futian, Shenzhen, China





4x4 Matrix Keypad

PRODUCT ID: 3844

Punch in your secret key (or Jenny's number) into this numeric matrix keypad. This keypad has 16 buttons, arranged in a telephone-line 4x4 grid. The keys are connected into a matrix, so you only need 8 microcontroller pins (4-columns and 4-rows) to scan through the pad. Check the tutorials tab for links to an Arduino library and example code.

We include some header so you can plug this into a breadboard with ease, some light soldering is required to attach it. Or you can use plain wires if you like.

There's a great Matrix Keypad Arduino library that should work great with this item with minor adjustments. It's basically a sturdier version of our Membrane 3x4 Matrix Keypad. Starting from the left there are four row pins, and then to the right are the four column pins.

If you dig our demo, check out the Adafruit FeatherWing OLED – 128x32 OLED

We also have a 3x4 version of this matrix keypad

TECHNICAL DETAILS

- Force: 160–180g
- Contact Resistance: <100Ω

There is a very nice Matrix Keypad Arduino library that works great with this item. The only thing we suggest is to change the initialization code in the examples to this, which matches the demo above

```
#include "Arduino.h"
#include "Keypad.h"

const byte ROWS = 4; //four rows
const byte COLS = 4; //four columns
char keys[ROWS][COLS] = {
  {'1','2','3','A'},
  {'4','5','6','B'},
  {'7','8','9','C'},
  {'*','0','#','D'}
};

byte rowPins[ROWS] = {A3, A2, A1, A0}; //connect to the row pinouts of the keypad
- four in a row

byte colPins[COLS] = {MOSI, SCK, A5, A4}; //connect to the column pinouts of the keypad
- four in a row

Keypad keypad = Keypad( makeKeymap(keys), rowPins, colPins, ROWS, COLS );

void setup() {
```

```
Serial.begin(9600);  
}  
  
void loop() {  
  char key = keypad.getKey();  
  
  if (key != NO_KEY){  
    Serial.println(key);  
  }  
}
```

Product Dimensions: 69.0mm x 65.5mm x 9.7mm / 2.7" x 2.6" x 0.4"

Product Weight: 21.2g / 0.7oz

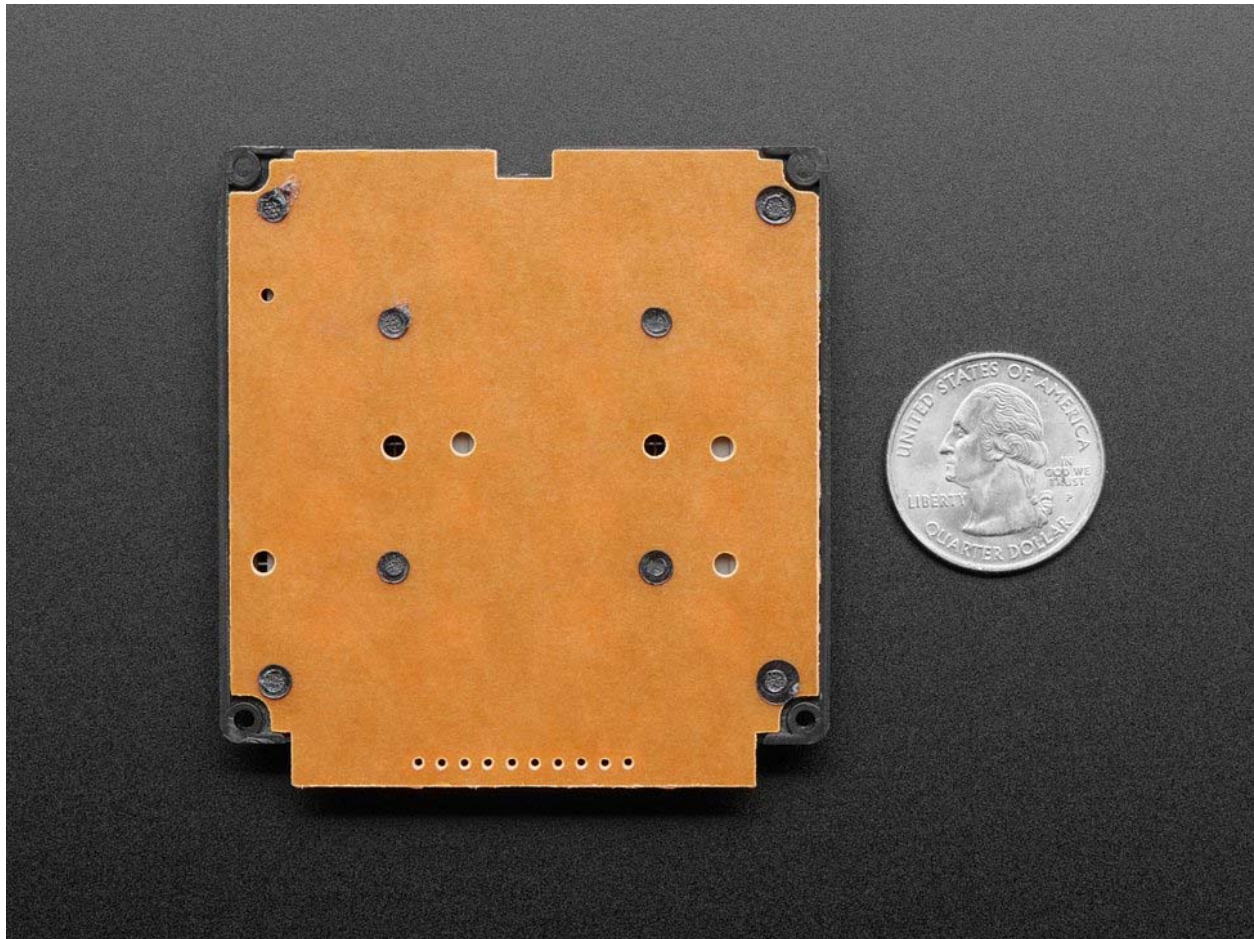



3844 Diagram

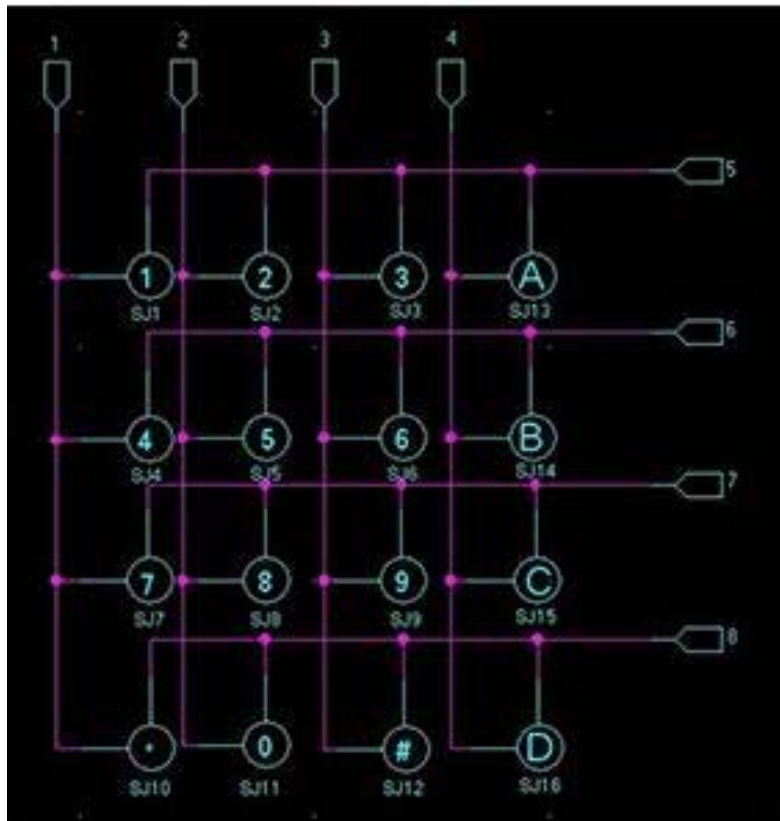

<https://www.adafruit.com/product/3844> 8-13-18