



Chipsmall Limited consists of a professional team with an average of over 10 year of expertise in the distribution of electronic components. Based in Hongkong, we have already established firm and mutual-benefit business relationships with customers from,Europe,America and south Asia,supplying obsolete and hard-to-find components to meet their specific needs.

With the principle of “Quality Parts,Customers Priority,Honest Operation,and Considerate Service”,our business mainly focus on the distribution of electronic components. Line cards we deal with include Microchip,ALPS,ROHM,Xilinx,Pulse,ON,Everlight and Freescale. Main products comprise IC,Modules,Potentiometer,IC Socket,Relay,Connector.Our parts cover such applications as commercial,industrial, and automotives areas.

We are looking forward to setting up business relationship with you and hope to provide you with the best service and solution. Let us make a better world for our industry!



## Contact us

Tel: +86-755-8981 8866 Fax: +86-755-8427 6832

Email & Skype: info@chipsmall.com Web: www.chipsmall.com

Address: A1208, Overseas Decoration Building, #122 Zhenhua RD., Futian, Shenzhen, China



M

38HM45

SPECIFICATION DETAILS:																						
STANDARD:	$\Delta 13$																					
CONSTRUCTION:																						
ENCLOSURE DESIGN	HERMETIC SEAL																					
CONTACT MATERIAL & CONFIGURATION	SILVER																					
CIRCUIT CONFIGURATION	SEE CIRCUIT DIAGRAM																					
TERMINATION	SEE DRAWING																					
WEIGHT																						
EXPOSED METALS	CORROSION RESISTANT STAINLESS STEEL																					
ELECTRICAL CHARACTERISTICS:																						
CONTACT ARRANGEMENT	S.P.N.C.																					
ELECTRICAL RATINGS	<table border="1"> <tr> <td>LOAD</td> <td>SEA LEVEL</td> <td>70,000 FT</td> </tr> <tr> <td></td> <td>28 VDC</td> <td>115 VAC, 400 CPS</td> </tr> <tr> <td></td> <td></td> <td>28 VDC</td> </tr> <tr> <td>RESISTIVE</td> <td>4 AMP</td> <td>2 AMP</td> </tr> <tr> <td>INDUCTIVE</td> <td>2 AMP</td> <td>2 AMP</td> </tr> <tr> <td>LAMP</td> <td>1 AMP</td> <td>.5 AMP</td> </tr> <tr> <td></td> <td></td> <td>1 AMP</td> </tr> </table>	LOAD	SEA LEVEL	70,000 FT		28 VDC	115 VAC, 400 CPS			28 VDC	RESISTIVE	4 AMP	2 AMP	INDUCTIVE	2 AMP	2 AMP	LAMP	1 AMP	.5 AMP			1 AMP
LOAD	SEA LEVEL	70,000 FT																				
	28 VDC	115 VAC, 400 CPS																				
		28 VDC																				
RESISTIVE	4 AMP	2 AMP																				
INDUCTIVE	2 AMP	2 AMP																				
LAMP	1 AMP	.5 AMP																				
		1 AMP																				
DIELECTRIC STRENGTH & INSULATION RES (BASIC SWITCH)																						
	<table border="1"> <tr> <td>DIELECTRIC STRENGTH</td> <td>INSULATION RESISTANCE</td> </tr> <tr> <td>(<math>\approx 60</math> Hz FOR 5 SECONDS)</td> <td>(500 VDC <math>\pm 10\%</math>)</td> </tr> <tr> <td>-BETWEEN TERMINALS AND EXPOSED NON-CURRENT CARRYING METAL</td> <td>1000 V Rms, 500 <math>\mu</math> A (MAX LEAKAGE) 1000 Megohm MIN</td> </tr> <tr> <td>-BETWEEN TERMINALS OF MUTUALLY INSULATED CIRCUITS</td> <td>1000 V Rms, 500 <math>\mu</math> A (MAX LEAKAGE) 1000 Megohm MIN</td> </tr> <tr> <td>-BETWEEN ALL UNCONNECTED TERMINALS OF THE SAME POLE</td> <td>1000 V Rms, 500 <math>\mu</math> A (MAX LEAKAGE) 1000 Megohm MIN</td> </tr> </table>	DIELECTRIC STRENGTH	INSULATION RESISTANCE	( $\approx 60$ Hz FOR 5 SECONDS)	(500 VDC $\pm 10\%$ )	-BETWEEN TERMINALS AND EXPOSED NON-CURRENT CARRYING METAL	1000 V Rms, 500 $\mu$ A (MAX LEAKAGE) 1000 Megohm MIN	-BETWEEN TERMINALS OF MUTUALLY INSULATED CIRCUITS	1000 V Rms, 500 $\mu$ A (MAX LEAKAGE) 1000 Megohm MIN	-BETWEEN ALL UNCONNECTED TERMINALS OF THE SAME POLE	1000 V Rms, 500 $\mu$ A (MAX LEAKAGE) 1000 Megohm MIN											
DIELECTRIC STRENGTH	INSULATION RESISTANCE																					
( $\approx 60$ Hz FOR 5 SECONDS)	(500 VDC $\pm 10\%$ )																					
-BETWEEN TERMINALS AND EXPOSED NON-CURRENT CARRYING METAL	1000 V Rms, 500 $\mu$ A (MAX LEAKAGE) 1000 Megohm MIN																					
-BETWEEN TERMINALS OF MUTUALLY INSULATED CIRCUITS	1000 V Rms, 500 $\mu$ A (MAX LEAKAGE) 1000 Megohm MIN																					
-BETWEEN ALL UNCONNECTED TERMINALS OF THE SAME POLE	1000 V Rms, 500 $\mu$ A (MAX LEAKAGE) 1000 Megohm MIN																					
SWITCH RESISTANCE	N/A																					
RECOMMENDATION OR USE IN APPL LESS THAN .5 amps AND/OR 12 volts	N/A $\Delta 14$																					
MECHANICAL CHARACTERISTICS:																						
OPERATING FORCE	9 OZ MAX																					
RELEASE FORCE	2 OZ MIN																					
DIFFERENTIAL TRAVEL	.030 MAX																					
OVERTRAVEL	.030 MIN																					
MOUNTING STRENGTH	N/A																					
LIFE:	$\Delta 13$																					
MECHANICAL LIFE	25,000 MIN																					
ELECTRICAL LIFE AT FULL RATED LOAD	25,000 MIN																					
ENVIRONMENTAL:																						
TEMPERATURE RANGE	-65°F TO +250°F																					
ALTITUDE RANGE	SEA LEVEL TO 70,000 FT																					
SHOCK $\Delta 13$	PER MIL-S-8805 SYMBOL M-100g																					
VIBRATION $\Delta 13$	PER MIL-S-8805 SYMBOL 2 - 10-2000 Hz & 15g PEAK																					
MOISTURE RESISTANCE $\Delta 13$	PER MIL-S-8805																					
THERMAL SHOCK $\Delta 13$	PER MIL-S-8805																					
SALT SPRAY $\Delta 13$	PER MIL-S-8805																					

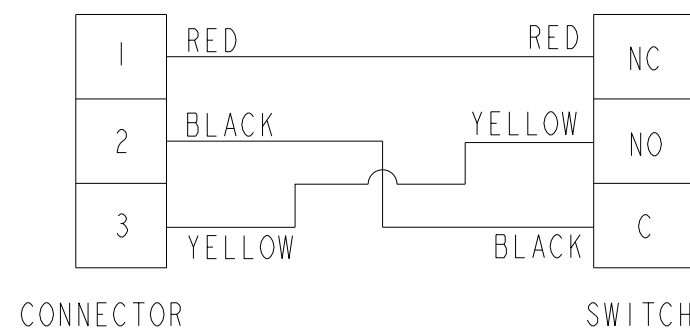

CIRCUIT DIAGRAM

- NOTES
- UNIT INCLUDES 2HM SERIES TYPE BASIC SWITCH WITH ACTUATOR ASSEMBLED
  - ADJUSTMENT CAUTION: DO NOT ALLOW ACTUATOR LEAF TO COME IN CONTACT WITH FIXED END OF HM LEVER, SEAL DAMAGE MAY OCCUR
  - LEAF ACTUATOR ADJUSTED TO MEET SPECIFIED OPERATING POSITION PRIOR TO DELIVERY. DISASSEMBLY AND SUBSEQUENT REASSEMBLY MAY ALTER THIS CONDITION
  - 3X NO. 18 WIRE LEAD PER MIL-W-22759/11 (RED N.C., BLACK COM. YELLOW N.O.)
  - 2X CORROSION RESISTANT STEEL LOCKWASHER
  - 2X 2-56 UNC X .500 CORROSION RESISTANT STEEL ROUND HEAD MACHINE SCREW
  - 2X 2-56 UNC CORROSION RESISTANT STEEL HEX NUT
  - $\varnothing .19$  X .12 WIDE CORROSION RESISTANT STEEL ROLLER (CONCENTRICITY .005 FIM)
  - HOLES THROUGH ACTUATOR WILL SIMULTANEOUS ACCEPT  $\varnothing .087$  MIN PINS ON  $.375 \pm .002$  CENTERS
  - INSULATION RESISTANCE BETWEEN EITHER PIN AND CONNECTOR SHELL MUST BE 100 MEGOHMS MIN AT 500 VDC
  - 3X HEAT SHRINK TUBING PER M23053/12-312-C OR EQUIVALENT
  - HEAT SHRINK TUBING PER M23053/12-325-C OR EQUIVALENT
  - BASIC SWITCH IS CATEGORY II DEVICE PER MIL-S-8805/8
  - CONTACT HONEYWELL/MICRO SWITCH IF ADDITIONAL INFORMATION ON LOW ENERGY LOADS IS REQUIRED OR FOR HELP WITH SPECIFIC APPLICATIONS

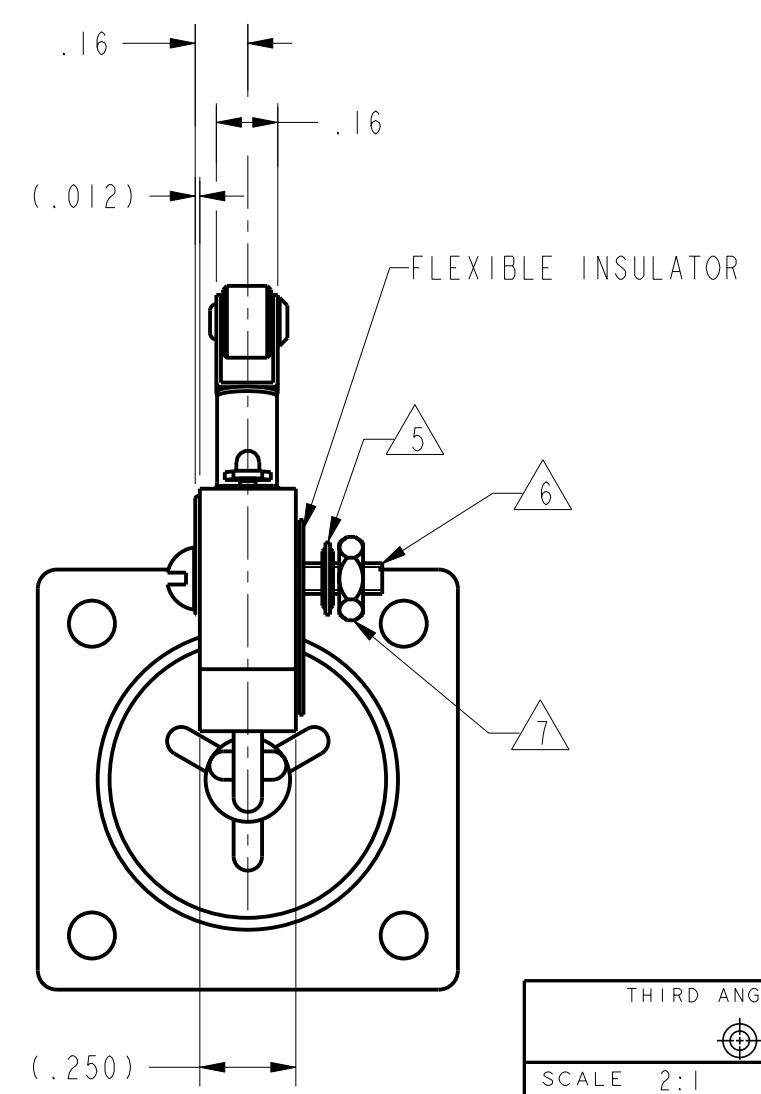
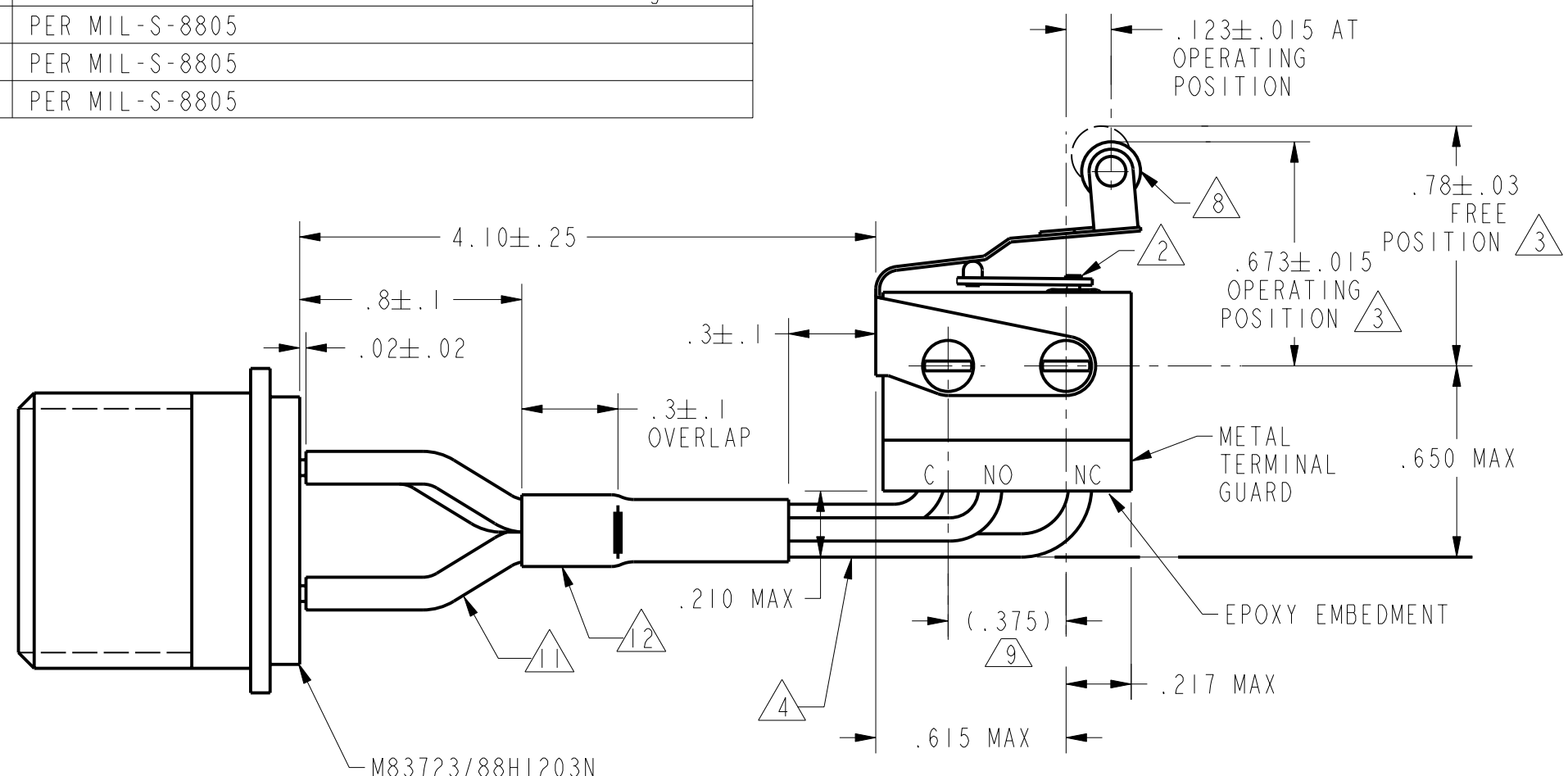

THIS DRAWING COVERS A PROPRIETARY ITEM AND IS THE PROPERTY OF MICRO SWITCH, A DIVISION OF HONEYWELL. THIS DRAWING IS NOT TO BE COPIED OR USED WITHOUT THE APPROVAL OF MICRO SWITCH.

**MICRO SWITCH**  
a Honeywell Division

**SWITCH AND CONNECTOR ASSEMBLY**

CATALOG LISTING  
**38HM45**

ANSI Y14.5M-1982 APPLIES  
FED. MFG. CODE 91929

THIRD ANGLE PROJECTION		
SCALE 2:1		
DO NOT SCALE PRINT		
UNLESS OTHERWISE SPECIFIED TOLERANCES ARE		
ONE PLACE	(.0)	$\pm .030$
TWO PLACES	(.00)	$\pm .015$
THREE PLACES	(.000)	$\pm .005$
ANGLES		$\pm$
WEIGHT		

38HM45  
 DRAWING NUMBER  
 ISSUE 5  
 P.T.C./CAD 20  
 DRAWN  
 CS1 21 FEB 03  
 CHECK  
 SAV 21 FEB 03  
 CHECK  
 21 FEB 03  
 RELEASE NO. PR-22237  
 REPLACES X100922-HM