



Chipsmall Limited consists of a professional team with an average of over 10 year of expertise in the distribution of electronic components. Based in Hongkong, we have already established firm and mutual-benefit business relationships with customers from,Europe,America and south Asia,supplying obsolete and hard-to-find components to meet their specific needs.

With the principle of "Quality Parts,Customers Priority,Honest Operation,and Considerate Service",our business mainly focus on the distribution of electronic components. Line cards we deal with include Microchip,ALPS,ROHM,Xilinx,Pulse,ON,Everlight and Freescale. Main products comprise IC,Modules,Potentiometer,IC Socket,Relay,Connector.Our parts cover such applications as commercial,industrial, and automotives areas.

We are looking forward to setting up business relationship with you and hope to provide you with the best service and solution. Let us make a better world for our industry!



Contact us

Tel: +86-755-8981 8866 Fax: +86-755-8427 6832

Email & Skype: info@chipsmall.com Web: www.chipsmall.com

Address: A1208, Overseas Decoration Building, #122 Zhenhua RD., Futian, Shenzhen, China



Low voltage high performance NPN power transistor

Features

- Very low collector-emitter saturation voltage
- High current gain characteristic
- Fast switching speed
- Miniature SOT-23 plastic package
ECOPACK[®]2 grade for surface mounting circuits

Applications

- Strobe and LED drives
- Motor and relay drives
- DC-DC converters

Description

This device is an NPN transistor manufactured using low voltage planar technology with a double-metal process.

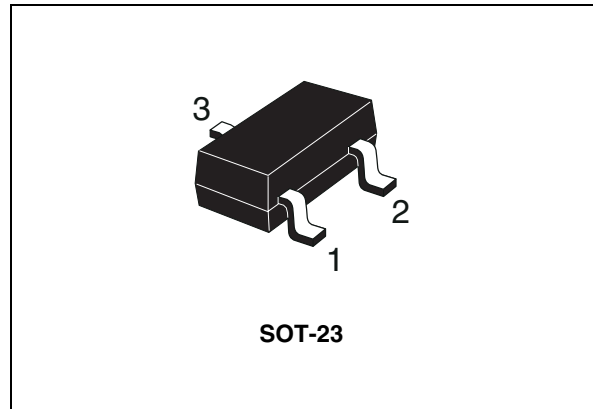

Figure 1. Internal schematic diagram

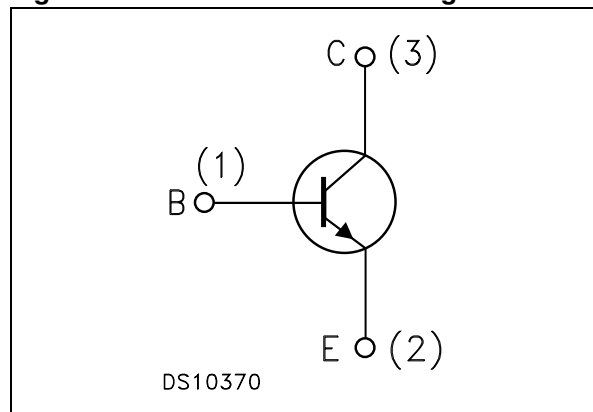

Table 1. Device summary

Order code	Marking	Package	Packing
3STR1630	1630	SOT-23	Tape and reel

1 Electrical ratings

Table 2. Absolute maximum ratings

Symbol	Parameter	Value	Unit
V_{CES}	Collector-emitter voltage ($V_{BE} = 0$)	30	V
V_{CEO}	Collector-emitter voltage ($I_B = 0$)	30	V
V_{EBO}	Emitter-base voltage ($I_C = 0$)	5	V
I_C	Collector current	6	A
I_{CM}	Collector peak current ($t_p < 5$ ms)	12	A
P_{TOT}	Total dissipation at $T_{amb} = 25$ °C	0.5	W
T_{STG}	Storage temperature	-65 to 150	°C
T_J	Max. operating junction temperature	150	°C

Table 3. Thermal data

Symbol	Parameter	Value	Unit
$R_{thJA}^{(1)}$	Thermal resistance junction-ambient max	250	°C/W

1. Device mounted on PCB area of 1 cm².

2 Electrical characteristics

$T_{\text{case}} = 25\text{ }^{\circ}\text{C}$ unless otherwise specified.

Table 4. Electrical characteristics

Symbol	Parameter	Test conditions	Min.	Typ.	Max.	Unit
I_{CBO}	Collector cut-off current ($I_{\text{E}} = 0$)	$V_{\text{CB}} = 30\text{ V}$			0.1	μA
I_{EBO}	Emitter cut-off current ($I_{\text{C}} = 0$)	$V_{\text{EB}} = 4\text{ V}$			0.1	μA
$V_{(\text{BR})\text{CBO}}$	Collector-base breakdown voltage ($I_{\text{E}} = 0$)	$I_{\text{C}} = 100\text{ }\mu\text{A}$	30			V
$V_{(\text{BR})\text{CEO}}^{(1)}$	Collector-emitter breakdown voltage ($I_{\text{B}} = 0$)	$I_{\text{C}} = 10\text{ mA}$	30			V
$V_{(\text{BR})\text{EBO}}$	Emitter-base breakdown voltage ($I_{\text{C}} = 0$)	$I_{\text{E}} = 100\text{ }\mu\text{A}$	5			V
$V_{\text{CE}(\text{sat})}^{(1)}$	Collector-emitter saturation voltage	$I_{\text{C}} = 1\text{ A}$ $I_{\text{B}} = 100\text{ mA}$ $I_{\text{C}} = 2\text{ A}$ $I_{\text{B}} = 40\text{ mA}$ $I_{\text{C}} = 5\text{ A}$ $I_{\text{B}} = 500\text{ mA}$		60 140 240	90 190 300	mV mV mV
$V_{\text{BE}(\text{sat})}^{(1)}$	Base-emitter saturation voltage	$I_{\text{C}} = 2\text{ A}$ $I_{\text{B}} = 40\text{ mA}$ $I_{\text{C}} = 5\text{ A}$ $I_{\text{B}} = 500\text{ mA}$		830 1000	1100	mV mV
$h_{\text{FE}}^{(1)}$	DC current gain	$I_{\text{C}} = 50\text{ mA}$ $V_{\text{CE}} = 2\text{ V}$ $I_{\text{C}} = 0.5\text{ A}$ $V_{\text{CE}} = 2\text{ V}$ $I_{\text{C}} = 2\text{ A}$ $V_{\text{CE}} = 2\text{ V}$ $I_{\text{C}} = 5\text{ A}$ $V_{\text{CE}} = 2\text{ V}$	210 180 170	260 90	560	
f_{t}	Transition frequency	$I_{\text{C}} = 0.1\text{ A}$ $V_{\text{CE}} = 10\text{ V}$		100		MHz
C_{CBO}	Collector-base capacitance ($I_{\text{E}} = 0$)	$V_{\text{CB}} = 40\text{ V}$, $f = 1\text{ MHz}$		15		pF
t_{on} t_{off}	Resistive load Turn-on time Turn-off time	$I_{\text{C}} = 2.5\text{ A}$ $V_{\text{CC}} = 12\text{ V}$ $I_{\text{B}1} = - I_{\text{B}2} = 125\text{ mA}$ $V_{\text{BE}(\text{off})} = -5\text{ V}$		90 450		ns ns

1. Pulse test: pulse duration $\leq 300\text{ }\mu\text{s}$, duty cycle $\leq 2\%$

2.1 Electrical characteristics (curves)

Figure 2. DC current gain ($V_{CE}=1\text{ V}$)

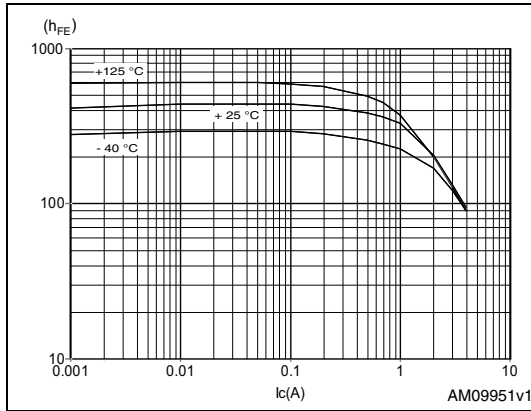

Figure 3. DC current gain ($V_{CE}=2\text{ V}$)

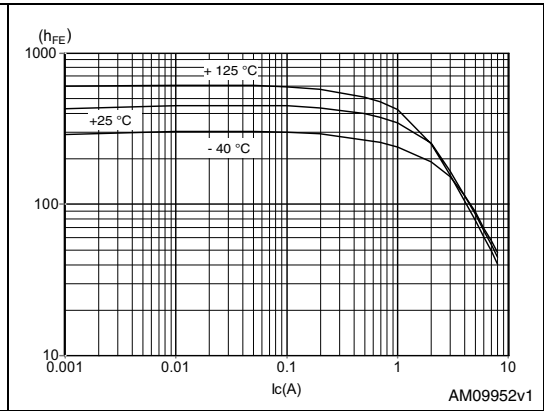

Figure 4. Collector-emitter saturation voltage (V_{CEsat} @ $h_{FE}=10$)

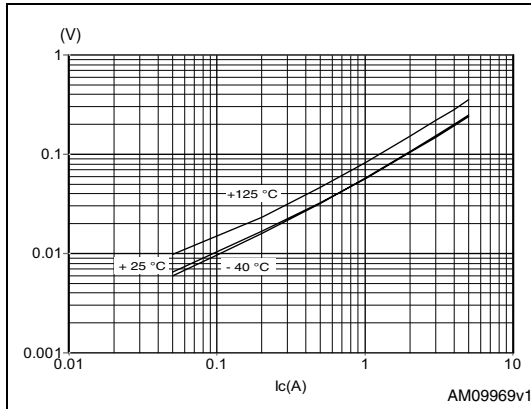

Figure 5. Collector-emitter saturation voltage (V_{CEsat} @ $h_{FE}=50$)

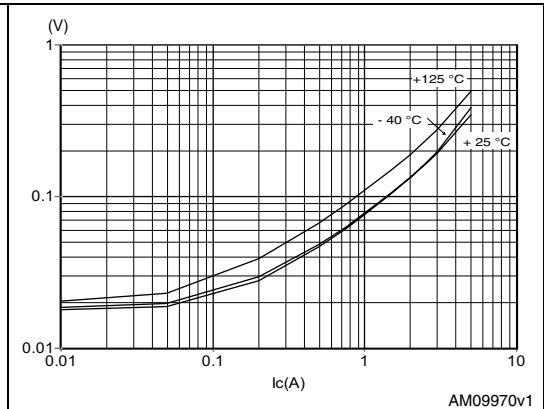

Figure 6. Base-emitter saturation voltage (V_{BEsat} @ $h_{FE}=10$)

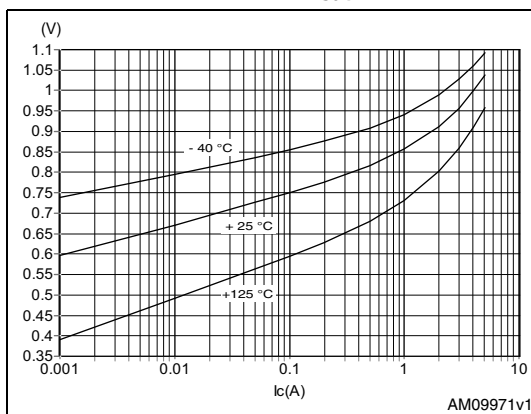

Figure 7. Base-emitter saturation voltage (V_{BEsat} @ $h_{FE}=50$)

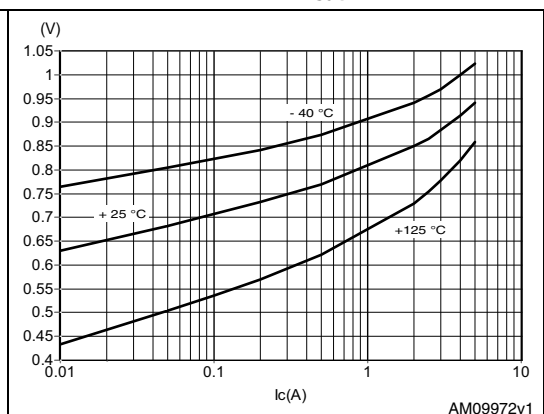

Figure 8. Resistive load switching time (ON)

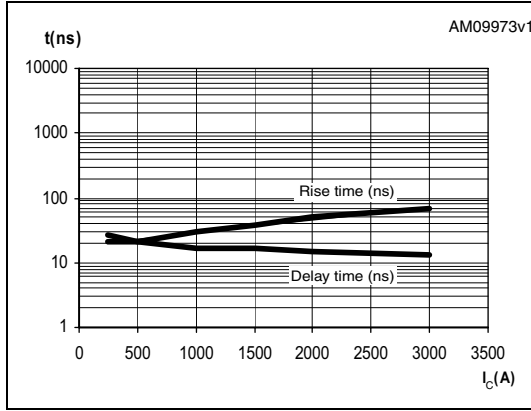

Figure 9. Resistive load switching time (OFF)

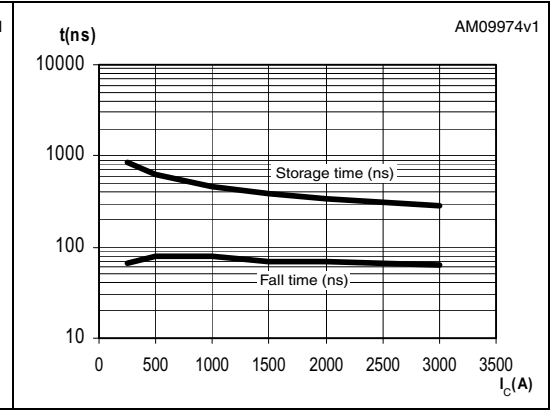

Figure 10. Capacitance curves

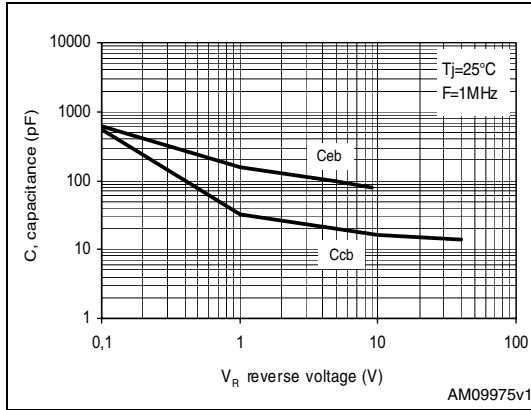
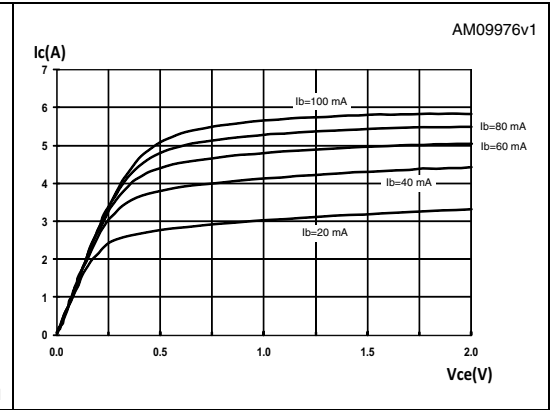
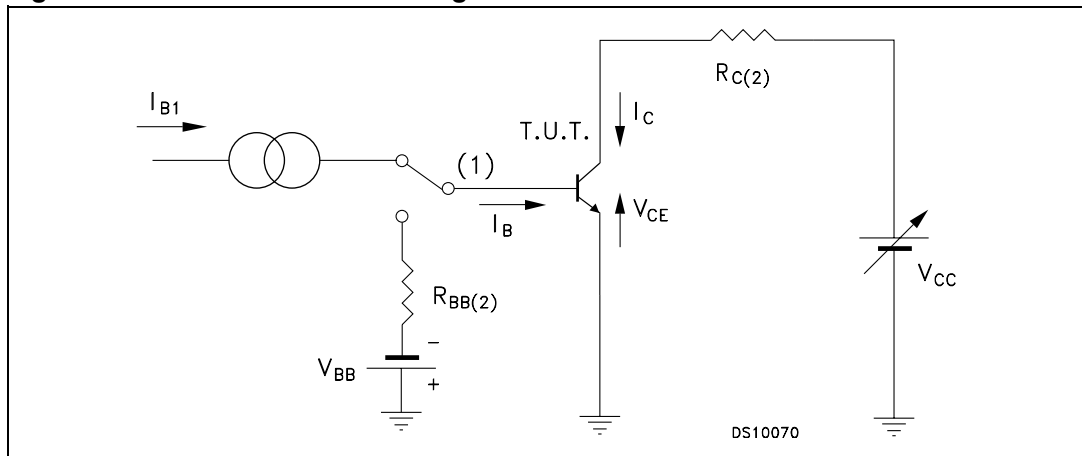

Figure 11. Output curve



2.2 Test circuits

Figure 12. Resistive load switching test circuit



1. Fast electronic switch
2. Non-inductive resistor

3 Package mechanical data

In order to meet environmental requirements, ST offers these devices in different grades of ECOPACK[®] packages, depending on their level of environmental compliance. ECOPACK[®] specifications, grade definitions and product status are available at: www.st.com. ECOPACK[®] is an ST trademark.

Table 5. SOT-23 mechanical data

Dim.	mm.		
	Min.	Typ.	Max.
A	0.89		1.4
A1	0		0.1
B	0.3		0.51
C	0.085		0.18
D	2.75		3.04
e	0.85		1.05
e1	1.7		2.1
E	1.2		1.6
H	2.1		2.75
L		0.6	
S	0.35		0.65

Figure 13. SOT-23 drawings

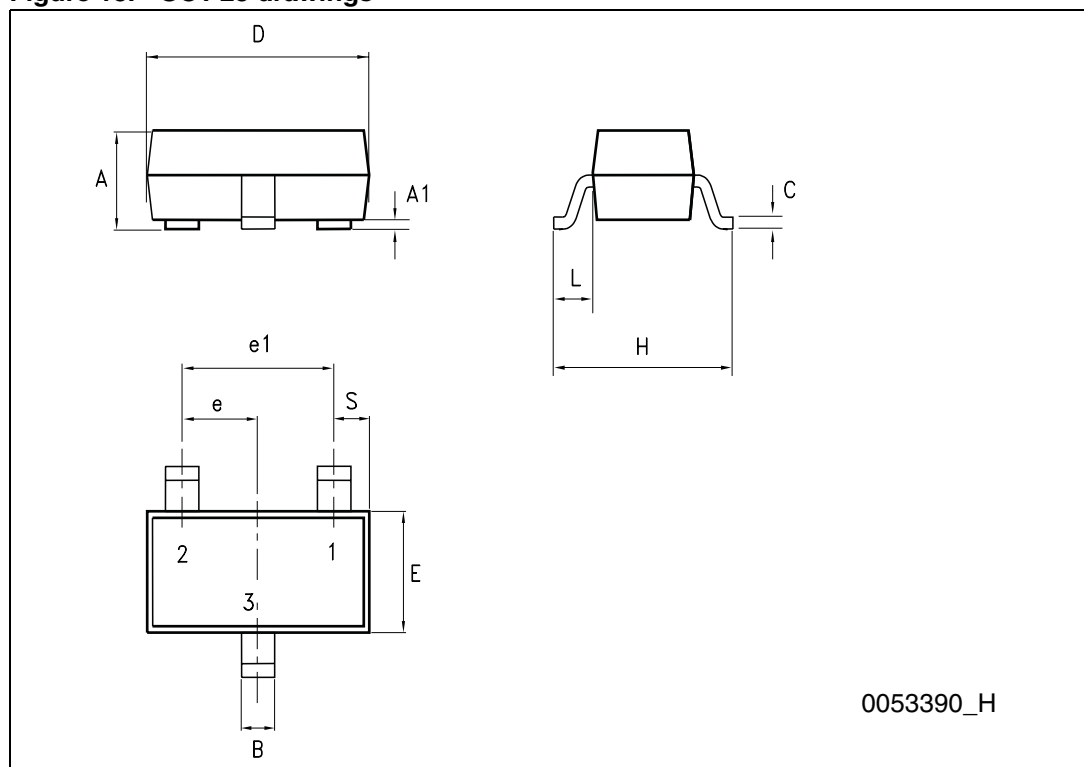

4 Revision history

Table 6. Document revision history

Date	Revision	Changes
02-Nov-2009	1	Initial release
17-Jan-2011	2	Removed "Preliminary data" text from coverpage header.
15-Jun-2011	3	Curves inserted Modified: Table 4

Please Read Carefully:

Information in this document is provided solely in connection with ST products. STMicroelectronics NV and its subsidiaries ("ST") reserve the right to make changes, corrections, modifications or improvements, to this document, and the products and services described herein at any time, without notice.

All ST products are sold pursuant to ST's terms and conditions of sale.

Purchasers are solely responsible for the choice, selection and use of the ST products and services described herein, and ST assumes no liability whatsoever relating to the choice, selection or use of the ST products and services described herein.

No license, express or implied, by estoppel or otherwise, to any intellectual property rights is granted under this document. If any part of this document refers to any third party products or services it shall not be deemed a license grant by ST for the use of such third party products or services, or any intellectual property contained therein or considered as a warranty covering the use in any manner whatsoever of such third party products or services or any intellectual property contained therein.

UNLESS OTHERWISE SET FORTH IN ST'S TERMS AND CONDITIONS OF SALE ST DISCLAIMS ANY EXPRESS OR IMPLIED WARRANTY WITH RESPECT TO THE USE AND/OR SALE OF ST PRODUCTS INCLUDING WITHOUT LIMITATION IMPLIED WARRANTIES OF MERCHANTABILITY, FITNESS FOR A PARTICULAR PURPOSE (AND THEIR EQUIVALENTS UNDER THE LAWS OF ANY JURISDICTION), OR INFRINGEMENT OF ANY PATENT, COPYRIGHT OR OTHER INTELLECTUAL PROPERTY RIGHT.

UNLESS EXPRESSLY APPROVED IN WRITING BY AN AUTHORIZED ST REPRESENTATIVE, ST PRODUCTS ARE NOT RECOMMENDED, AUTHORIZED OR WARRANTED FOR USE IN MILITARY, AIR CRAFT, SPACE, LIFE SAVING, OR LIFE SUSTAINING APPLICATIONS, NOR IN PRODUCTS OR SYSTEMS WHERE FAILURE OR MALFUNCTION MAY RESULT IN PERSONAL INJURY, DEATH, OR SEVERE PROPERTY OR ENVIRONMENTAL DAMAGE. ST PRODUCTS WHICH ARE NOT SPECIFIED AS "AUTOMOTIVE GRADE" MAY ONLY BE USED IN AUTOMOTIVE APPLICATIONS AT USER'S OWN RISK.

Resale of ST products with provisions different from the statements and/or technical features set forth in this document shall immediately void any warranty granted by ST for the ST product or service described herein and shall not create or extend in any manner whatsoever, any liability of ST.

ST and the ST logo are trademarks or registered trademarks of ST in various countries.

Information in this document supersedes and replaces all information previously supplied.

The ST logo is a registered trademark of STMicroelectronics. All other names are the property of their respective owners.

© 2011 STMicroelectronics - All rights reserved

STMicroelectronics group of companies

Australia - Belgium - Brazil - Canada - China - Czech Republic - Finland - France - Germany - Hong Kong - India - Israel - Italy - Japan - Malaysia - Malta - Morocco - Philippines - Singapore - Spain - Sweden - Switzerland - United Kingdom - United States of America

www.st.com