



Chipsmall Limited consists of a professional team with an average of over 10 year of expertise in the distribution of electronic components. Based in Hongkong, we have already established firm and mutual-benefit business relationships with customers from,Europe,America and south Asia,supplying obsolete and hard-to-find components to meet their specific needs.

With the principle of “Quality Parts,Customers Priority,Honest Operation,and Considerate Service”,our business mainly focus on the distribution of electronic components. Line cards we deal with include Microchip,ALPS,ROHM,Xilinx,Pulse,ON,Everlight and Freescale. Main products comprise IC,Modules,Potentiometer,IC Socket,Relay,Connector.Our parts cover such applications as commercial,industrial, and automotives areas.

We are looking forward to setting up business relationship with you and hope to provide you with the best service and solution. Let us make a better world for our industry!



Contact us

Tel: +86-755-8981 8866 Fax: +86-755-8427 6832

Email & Skype: info@chipsmall.com Web: www.chipsmall.com

Address: A1208, Overseas Decoration Building, #122 Zhenhua RD., Futian, Shenzhen, China



THIS DRAWING IS UNPUBLISHED. RELEASED FOR PUBLICATION
 © COPYRIGHT - By - ALL RIGHTS RESERVED.

LOC	DIST	REVISIONS					
AF	50	P	LTR	DESCRIPTION	DATE	DWN	APVD
		J		REVISED PER ECR-12-005303	24JUL12	KH	KR

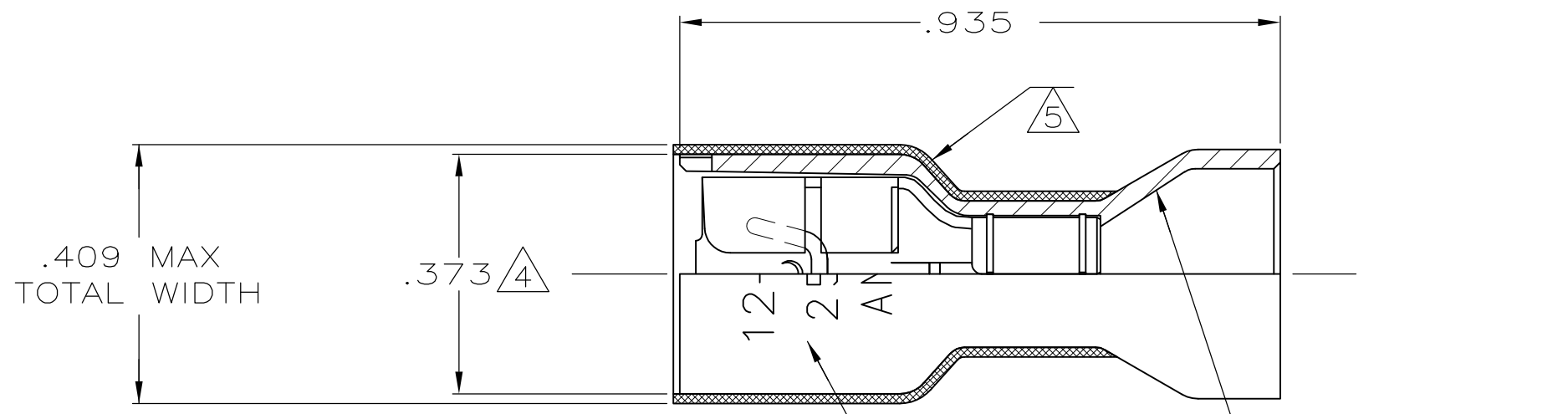

- 1 MATES WITH .032±.001x.250 TAB
- 2 WIRE STRIP LENGTH .312
- 3 INSULATION SIZE .320 MAX DIA
- △4 DIMENSION DOES NOT INCLUDE TRIM BURR
- △5 .015 MAX CARRIER TRIM BURR PER SIDE IS ALLOWABLE IN THE SHADED AREA

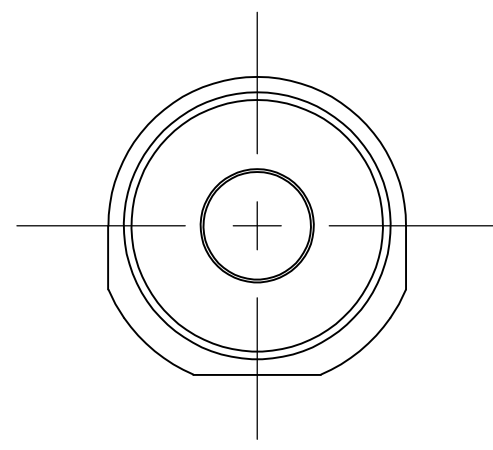
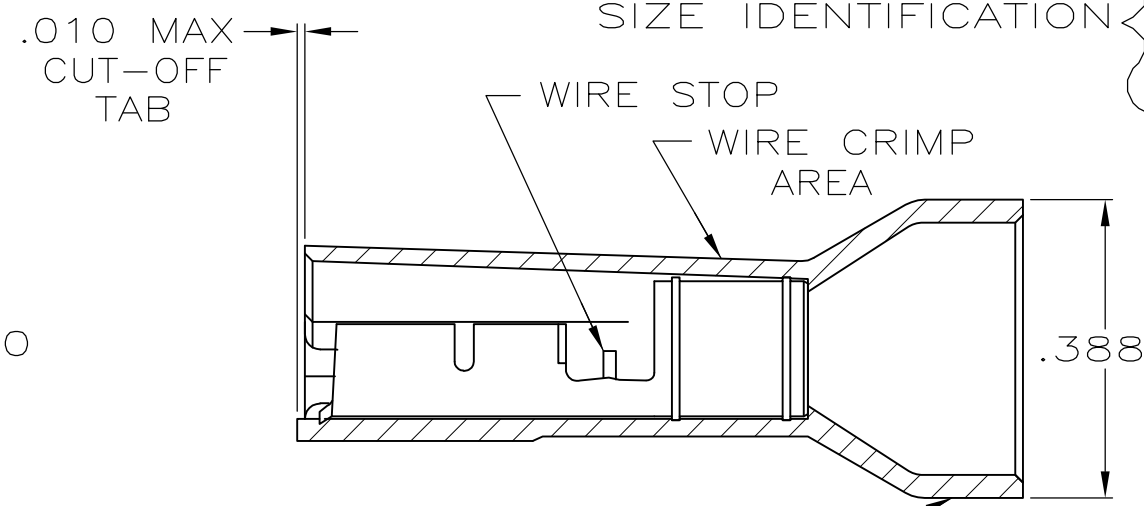
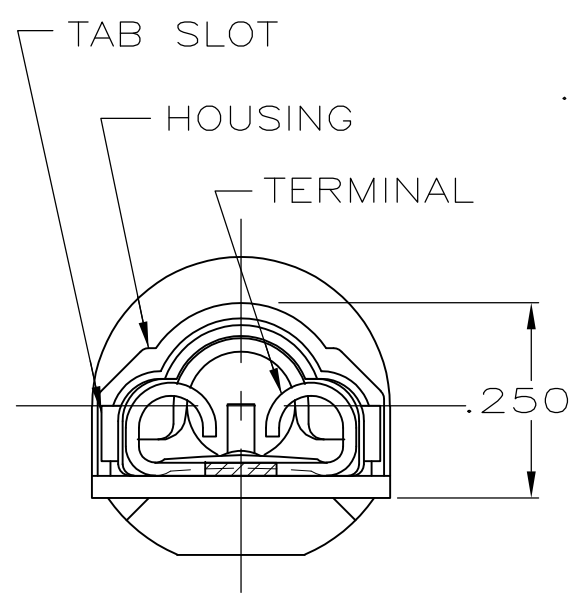

HOUSING: NYLON, COLOR-YELLOW TRANSLUCENT	4-520448-2
RECEPTACLE: #3 HARD BRASS, TIN	
MATERIAL & FINISH	PART NO

THIS DRAWING IS A CONTROLLED DOCUMENT.		DWN P FORTNEY 11/4/88	TE Connectivity RECEPTACLE ASSEMBLY, ULTRA-FAST, LOOSE PIECE .250 SERIES, 12-10 AWG		
DIMENSIONS: INCHES		CHK MS FEHER 11/7/88			
TOLERANCES UNLESS OTHERWISE SPECIFIED:		APVD K RANDOLPH 11/7/88			
0 PLC ± - 1 PLC ± - 2 PLC ± - 3 PLC ± .015 4 PLC ± - ANGLES ± -		NAME			
MATERIAL SEE TABLE		FINISH SEE TABLE	PRODUCT SPEC 108-2043	APPLICATION SPEC 114-2035	RESTRICTED TO
CUSTOMER DRAWING			WEIGHT -	SIZE A3	CAGE CODE 00779
			DRAWING NO C-520448	SCALE 4:1	SHEET 1 OF 1
				REV J	