



Chipsmall Limited consists of a professional team with an average of over 10 year of expertise in the distribution of electronic components. Based in Hongkong, we have already established firm and mutual-benefit business relationships with customers from,Europe,America and south Asia,supplying obsolete and hard-to-find components to meet their specific needs.

With the principle of "Quality Parts,Customers Priority,Honest Operation,and Considerate Service",our business mainly focus on the distribution of electronic components. Line cards we deal with include Microchip,ALPS,ROHM,Xilinx,Pulse,ON,Everlight and Freescale. Main products comprise IC,Modules,Potentiometer,IC Socket,Relay,Connector.Our parts cover such applications as commercial,industrial, and automotives areas.

We are looking forward to setting up business relationship with you and hope to provide you with the best service and solution. Let us make a better world for our industry!



Contact us

Tel: +86-755-8981 8866 Fax: +86-755-8427 6832

Email & Skype: info@chipsmall.com Web: www.chipsmall.com

Address: A1208, Overseas Decoration Building, #122 Zhenhua RD., Futian, Shenzhen, China



THIS DRAWING IS UNPUBLISHED. RELEASED FOR PUBLICATION
 © COPYRIGHT - By - ALL RIGHTS RESERVED.

LOC	DIST	REVISIONS			
P	LTR	DESCRIPTION	DATE	DWN	APVD
AF	50	E	REVISED PER ECR-12-005303	23JUL12	KH KR

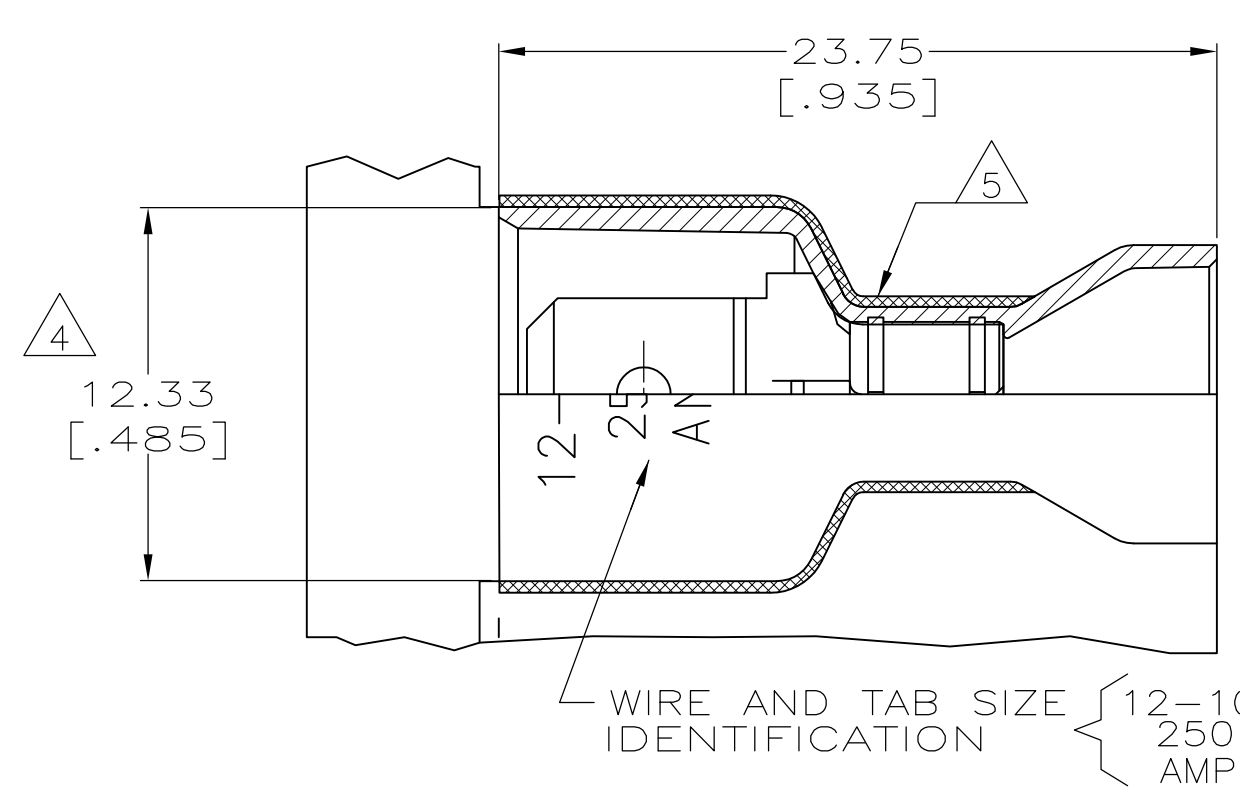

- 1 TAB DIMENSIONS $0.81^{+.025}_{-.050} \times 6.35$
[.032 $^{+.001}_{-.002}$ x .250]
- 2 WIRE STRIP LENGTH 7.92 [.312].
- 3 CONTINUOUS STRIP ON REELS.
- 4 DIMENSION DOES NOT INCLUDE TRIM BURR.
- 5 0.38 [.015] MAX CARRIER TRIM BURR PER SIDE IS ALLOWABLE IN THE SHADED AREA.
- 6 INSULATION SIZE IS .320 MAX DIA.

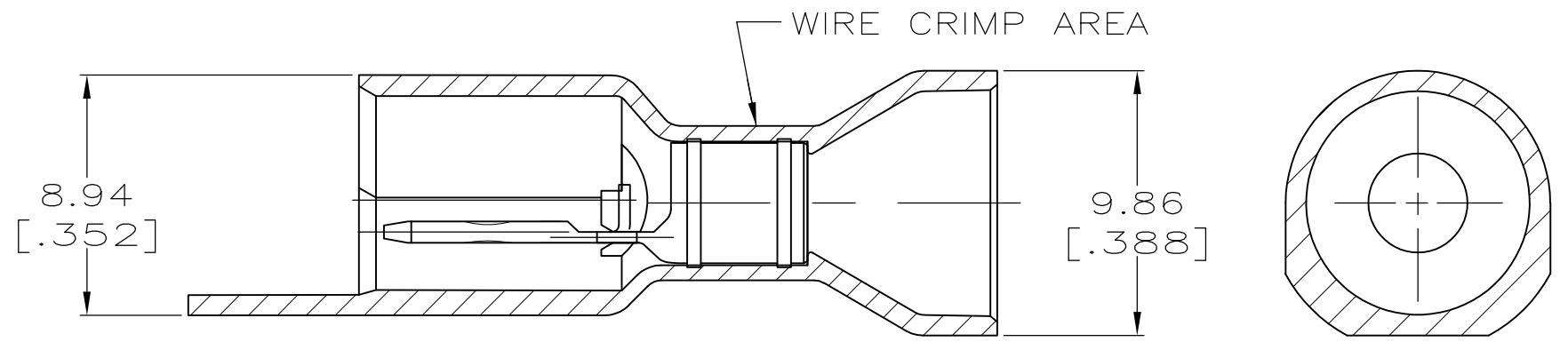
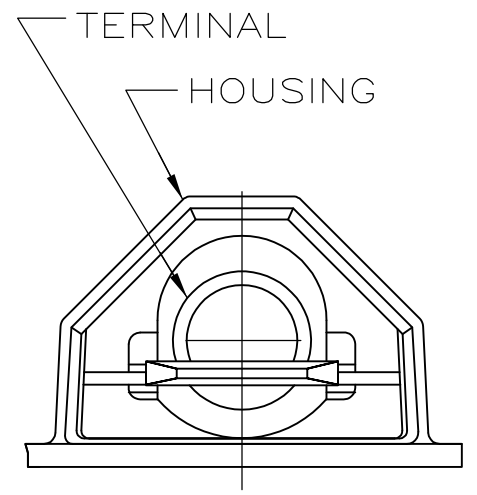

HOUSING: NYLON, COLOR-YELLOW TAB: #3 HARD BRASS, TIN	4-521097-2
MATERIAL & FINISH	PART NO

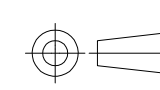
THIS DRAWING IS A CONTROLLED DOCUMENT.		DWN JR RUTH 9/25/95	 TE Connectivity NAME TAB ASSEMBLY, ULTRA-FAST, [6.35] .250 SERIES, 12-10 AWG		
DIMENSIONS: INCHES	TOLERANCES UNLESS OTHERWISE SPECIFIED:	CHK P FORTNEY 9/25/95			
	0 PLC ± -	APVD D BRATINA 9/25/95			
	1 PLC ± -	PRODUCT SPEC 108-2017			
MATERIAL SEE TABLE	FINISH SEE TABLE	APPLICATION SPEC 114-2123	SIZE A3	CAGE CODE 00779	DRAWING NO C-521097
CUSTOMER DRAWING			RESTRICTED TO -	SCALE 4:1	SHEET 1 OF 1