



Chipsmall Limited consists of a professional team with an average of over 10 year of expertise in the distribution of electronic components. Based in Hongkong, we have already established firm and mutual-benefit business relationships with customers from,Europe,America and south Asia,supplying obsolete and hard-to-find components to meet their specific needs.

With the principle of “Quality Parts,Customers Priority,Honest Operation,and Considerate Service”,our business mainly focus on the distribution of electronic components. Line cards we deal with include Microchip,ALPS,ROHM,Xilinx,Pulse,ON,Everlight and Freescale. Main products comprise IC,Modules,Potentiometer,IC Socket,Relay,Connector.Our parts cover such applications as commercial,industrial, and automotives areas.

We are looking forward to setting up business relationship with you and hope to provide you with the best service and solution. Let us make a better world for our industry!



Contact us

Tel: +86-755-8981 8866 Fax: +86-755-8427 6832

Email & Skype: info@chipsmall.com Web: www.chipsmall.com

Address: A1208, Overseas Decoration Building, #122 Zhenhua RD., Futian, Shenzhen, China



Thermofit[®] Molded Parts Specification Control Drawing

Part Number : 402A013
Description : Transition, 1 to 3
Cables, Parallel

NOTES

- All dimensions are in $\frac{\text{inches}}{\text{millimeters}}$
- Dimensions appearing in table are as follows:
a - As Supplied
b - After Unrestricted Recovery
- Coating is optional. As supplied dimensions appearing in table are for uncoated parts. When coating is added, entry diameters will be reduced by .06 max.
- Molding ports are optional. When -00 modification number is specified molding ports will be located as shown.

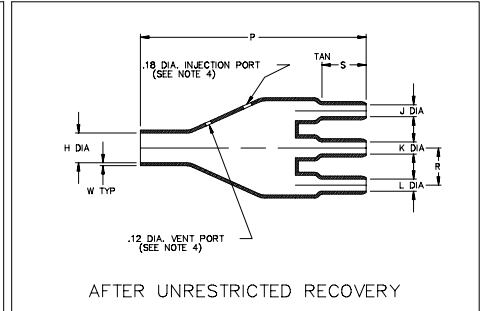
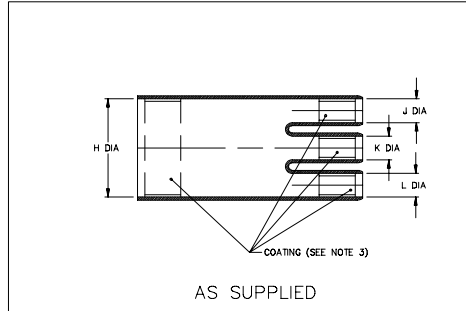

PART NUMBER	H		J, K & L		P	R	S	W
	Min a	Max b	Min a	Max b	±10% b	±10% b	±10% b	±20% b
402A013	1.00 [25,4]	.69 [17,5]	.50 [12,7]	.28 [7,1]	4.25 [108,0]	.72 [18,3]	.75 [19,1]	.06 [1,5]

**If this document is printed it becomes uncontrolled.
Check for the latest revision.**

Raychem

RAYCHEM CORPORATION
300 CONSTITUTION DRIVE
MENLO PARK, CALIFORNIA 94025

Revision : K
Date : 4/21/94

Part Number : 402A013
Description : Transition, 1 to 3
Cables, Parallel

Thermofit[®] Molded Parts Specification Control Drawing

Part Number : 402A013
Description : Transition, 1 to 3
Cables, Parallel

MATERIAL DASH NO.	MATERIAL DESCRIPTION	RT SPEC	COATING SLASH NO.	COATING S NO.	COATING DESCRIPTION
-3	Polyolefin, Semi-rigid	RT-301	/42	S-1017	Adhesive
-4	Polyolefin, Flexible	RT-1304	/42	S-1017	Adhesive
-5	Elastomer, Flexible	RT-501	/42		
-6	Silicone	RT-602	N/A		
-25	Elastomer, Fluid Resistant	RT-1325	N/A		

ORDERING INFORMATION			
Base part number	402A013	-XX	-XX /XX
Material dash number (See Compatability Chart)			
Modification number (If necessary, see front of scd binder for a complete list)			
Adhesive slash number (If necessary, see Compatability Chart)			

THIS DRAWING IS SUBJECT TO CHANGE WITHOUT NOTICE; CONSULT YOUR
NEAREST FIELD REPRESENTATIVE FOR CURRENT REVISION

Raychem

RAYCHEM CORPORATION
300 CONSTITUTION DRIVE
MENLO PARK, CALIFORNIA 94025

Revision : K
Date : 4/21/94

Part Number : 402A013
Description : Transition, 1 to 3
Cables, Parallel
CAD FILE MP94134