



Chipsmall Limited consists of a professional team with an average of over 10 year of expertise in the distribution of electronic components. Based in Hongkong, we have already established firm and mutual-benefit business relationships with customers from,Europe,America and south Asia,supplying obsolete and hard-to-find components to meet their specific needs.

With the principle of “Quality Parts,Customers Priority,Honest Operation,and Considerate Service”,our business mainly focus on the distribution of electronic components. Line cards we deal with include Microchip,ALPS,ROHM,Xilinx,Pulse,ON,Everlight and Freescale. Main products comprise IC,Modules,Potentiometer,IC Socket,Relay,Connector.Our parts cover such applications as commercial,industrial, and automotives areas.

We are looking forward to setting up business relationship with you and hope to provide you with the best service and solution. Let us make a better world for our industry!



Contact us

Tel: +86-755-8981 8866 Fax: +86-755-8427 6832

Email & Skype: info@chipsmall.com Web: www.chipsmall.com

Address: A1208, Overseas Decoration Building, #122 Zhenhua RD., Futian, Shenzhen, China



SEE NOTE 3
(4) PL.

SEE NOTE 3
(4) PL.

OPTIONAL
GROUNDING TABS (40247)
AND SCREWS (40327) (2) PL.
SEE NOTE 2 AND DRAWING 39983

6123 CHIP SHOWN HERE

OPTIONAL
GROUNDING TABS (40247)
AND SCREWS (40327) (2) PL.
SEE NOTE 2 AND DRAWING 39983

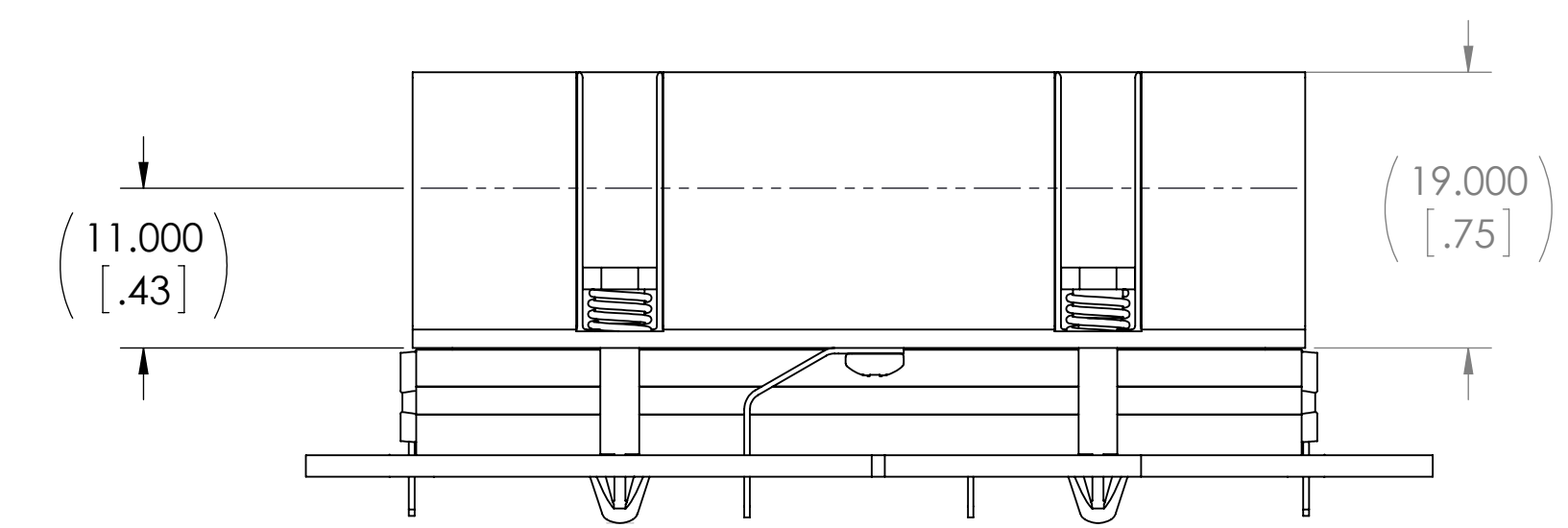

APPLIES TO BOTH 11MM AND 19MM HEATSINKS

ISO ASSY REF ONLY
LONGITUDINAL FLOW

ISO REF ONLY

THERMAL
INTERFACE
MATERIAL

GROUND TABS
AND SCREWS
TORQUE M2 SCREWS
TO 2 IN-LB (.2 Nm)

BOTTOM VIEW

X-FLOW (XF)
(HEAT SINK ONLY SHOWN)

LONGITUDINAL FLOW (LF)
(HEAT SINK ONLY SHOWN)

- NOTES:
- FOR PCB LAYOUT SEE VICOR APPLICATION DRAWING 39983.
 - THE SOLDERING METHOD USED FOR CHIPS (AND OPTIONAL HEATSINK GROUNDING) IS IMPORTANT WHEN SELECTING A THERMAL INTERFACE MATERIAL (TIM). THE PHASE-CHANGE TIM SHOWN IN THESE ILLUSTRATIONS MAY BE DAMAGED BY TEMPERATURES OVER 125C. SO TWO ASSEMBLY PROCEDURES ARE DESCRIBED BELOW: (A) FOR HAND-SOLDERING ONLY. (B) FOR WAVE-SOLDERING AND/OR HAND-SOLDERING.

(A) PLACE CHIP AND TOP-SIDE HEATSINK (WITH PRE-ATTACHED TIM AND GROUNDING TABS) ON PCB. WHILE SUPPORTING PCB, INSERT PLASTIC PUSH-PINS THROUGH HEATSINK AND PCB. (SELECT PROPER PUSH-PIN LENGTH FROM TABLE ON THIS DRAWING.) HAND-SOLDER CHIP AND GROUNDING PINS.

(B) WAVE SOLDERING TEMPERATURES ARE UNSUITABLE FOR PLASTIC PUSH-PINS AND PHASE-CHANGE TIM, SO VICOR TIM 40325 (PARKER CHOMERICS GEL8010) IS RECOMMENDED. APPLY A UNIFORM .003" (.076MM) LAYER OF TIM 40325 TO THE TOP SURFACE OF THE CHIP, OR TO THE BOTTOM SURFACE OF THE HEATSINK. PLACE CHIP ON PCB AND TOP-SIDE HEATSINK ON CHIP. WITH A CUSTOM FIXTURE APPLY APPROX. 10 LBS LOAD TO THE TOP-SIDE HEATSINK AND THEN WAVE-SOLDER ALL PINS. REMOVE FIXTURE AND, WHILE SUPPORTING PCB, INSERT PLASTIC PUSH-PINS THROUGH HEATSINK AND PCB. (SELECT PROPER PUSH-PIN LENGTH FROM TABLE ON THIS DRAWING.)
 - CARE SHOULD BE TAKEN TO AVOID FULLY COMPRESSING THE PUSH-PIN SPRING DURING INSTALLATION AS THIS WOULD EXPOSE THE CHIP TO FORCES GREATER THAN THE RECOMMENDED LIMIT OF 3.1 LBF (13.8 N) PER PUSH-PIN.
 - RoHS COMPLIANT PER CST-0001 LATEST REVISION.

PUSH-PIN FOR CHIP HEATSINK CHART

PUSH-PINS W/ SPRINGS (100/BAG)	COLOR	PCB THK NOMINAL RANGE	PCB THK MINIMUM	PCB THK MAXIMUM
32434	WHITE	1.143 MM TO 1.422 MM [.045"] TO [.056"]	1.016 MM [.040"]	1.575 MM [.062"]
32435	BLACK	1.448 MM TO 2.311 MM [.057"] TO [.091"]	1.295 MM [.051"]	2.565 MM [.101"]
32436	BLUE	2.337 MM TO 3.023 MM [.092"] TO [.119"]	2.083 MM [.082"]	3.353 MM [.132"]
32437	GRAY	3.048 MM TO 3.607 MM [.120"] TO [.142"]	2.743 MM [.108"]	3.988 MM [.157"]

	HEATSINK TYPE	P/N HEATSINK ONLY	P/N HEATSINK W/ TIM ONLY	P/N HEATSINK, TIM AND GROUND TAB	P/N HEATSINK W/GROUND TAB ONLY
SOLDERING METHOD (SEE NOTE 2)	-	2(B) WITH VICOR 40325 THERMAL GEL	2(A) HAND SOLDER ONLY	2(A) HAND SOLDER ONLY	2(B) WITH VICOR 40325 THERMAL GEL
	4623	XF 11MM	39970	40492	40140
LF 11MM		39969	40493	40144	40483
XF 19MM		40431	TBD	40531	TBD
6123	LF 19MM	40432	TBD	40532	TBD
	XF 11MM	39972	40494	40141	40484
	LF 11MM	39971	40495	40145	40485
	XF 19MM	40406	TBD	40533	TBD
	LF 19MM	40407	TBD	40534	TBD

DRAWN BY Robert Wasik	DATE 07/24/2013	VICOR	
UNLESS OTHERWISE SPECIFIED DIMENSIONS ARE: INCH / [MM]		APP DWG, CHIP PUSHPIN TOPSIDE HS, 6123, 4623	
TOLERANCES ARE: DECIMALS: .001" (0.025) ANGLES: ±1° XXX (X.X) = ±0.01 (0.25) X.XXX (X.XXX) = ±0.005 (0.127)		SIZE D	CAGE CODE 67131
THIRD ANGLE PROJECTION DO NOT SCALE DRAWING		DWG NO 40113	REV 1
SCALE 2:1		SHEET 1 OF 1	