



Chipsmall Limited consists of a professional team with an average of over 10 year of expertise in the distribution of electronic components. Based in Hongkong, we have already established firm and mutual-benefit business relationships with customers from,Europe,America and south Asia,supplying obsolete and hard-to-find components to meet their specific needs.

With the principle of “Quality Parts,Customers Priority,Honest Operation,and Considerate Service”,our business mainly focus on the distribution of electronic components. Line cards we deal with include Microchip,ALPS,ROHM,Xilinx,Pulse,ON,Everlight and Freescale. Main products comprise IC,Modules,Potentiometer,IC Socket,Relay,Connector.Our parts cover such applications as commercial,industrial, and automotives areas.

We are looking forward to setting up business relationship with you and hope to provide you with the best service and solution. Let us make a better world for our industry!



## Contact us

Tel: +86-755-8981 8866 Fax: +86-755-8427 6832

Email & Skype: info@chipsmall.com Web: www.chipsmall.com

Address: A1208, Overseas Decoration Building, #122 Zhenhua RD., Futian, Shenzhen, China



## PmodSF™ Reference Manual

Revised May 24, 2016

This manual applies to the PmodSF rev. C

---

### Overview

The PmodSF provides users with 16Mbit of non-volatile memory through the use of [ST Microelectronics M25P16](#). By using the SPI protocol, users can both write to and read from the flash memory.

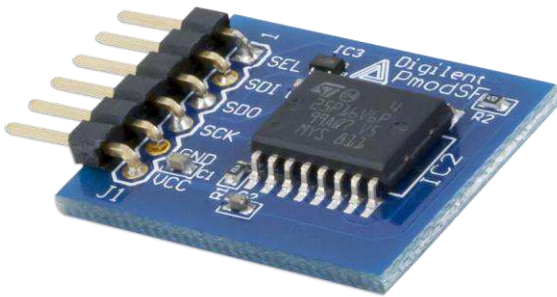

*The PmodSF.*

Features include:

- 16Mbit serial Flash memory
- Data retention greater than 20 years
- Small PCB size for flexible designs 1.0" × 20/8" (2.5 cm × 2.0 cm)
- 6-pin Pmod connector with SPI interface
- Follows [Digilent Interface Specification](#) Type 2
- Library and example code available in [resource center](#)

## 1 Functional Description

The PmodSF utilizes ST Microelectronics M25P16 which provides 16 Mbits of flash memory that can be accessed through the SPI protocol. Although this amount of memory is very small compared to modern flash drives, the PmodSF is a great way to get introduced to controlling non-volatile memory and can be easily incorporated into projects that need a way to store some information without using the USB interface.

## 2 Interfacing with the Pmod

The PmodSF communicates with the host board via the SPI protocol. By bringing the Chip Select (CS) line low, users are able to issue a variety of read, write, and erase commands to the memory chip. A table of the available commands for the M25P16 from its respective datasheet is provided below:

Instruction	Description	One-Byte Instruction Code	Number of Address Bytes	Number of Dummy Bytes	Number of Data Bytes
WREN	Write Enable	0x06	0	0	0
WRDI	Write Disable	0x04	0	0	0
RDID	Read Identification	0x9F	0	0	1 to 3
RDSR	Read Status Register	0x05	0	0	1 to ∞
WRSR	Write Status Register	0x01	0	0	1
READ	Read Data Bytes	0x03	3	0	1 to ∞
FAST_READ	Read Data Bytes at Higher Speed	0x0B	3	1	1 to ∞
PP	Page Program	0x02	3	0	1 to 256
SE	Sector Erase	0xD8	3	0	0
BE	Bulk Erase	0xC7	0	0	0
DP	Deep Power-down	0xB9	0	0	0
RES	Release from DP and Read Electronic Signature	0xAB	0	3	1 to ∞
	Release from DP		0	0	0

The address bits range from 0x000000 to 0x1FFFFFF, with the first two hexadecimal bits indicating which memory sector the data is located in. Thankfully, users do not have to explicitly worry about writing to and reading from the memory module, as there is a library that takes care of these commands for us.

Pin	Signal	Description
1	~CS	Chip Select
2	MOSI	Master-Out-Slave-In
3	MISO	Master-In-Slave-Out
4	SCK	Serial Clock
5	GND	Power Supply Ground
6	VCC	Positive Power Supply (3.3V)

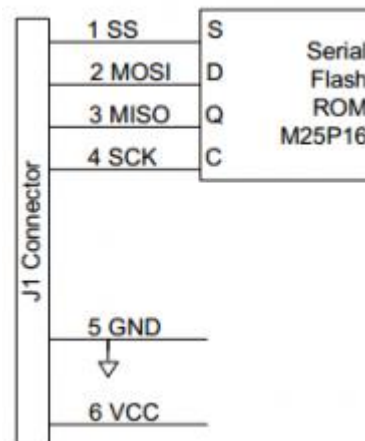

Any external power applied to the PmodSF must be within 2.7V and 3.6V; it is recommended that the Pmod is operated at 3.3V.

## 2 Physical Dimensions

The pins on the pin header are spaced 100 mil apart. The PCB is 1 inch long on the sides parallel to the pins on the pin header and 0.8 inches long on the sides perpendicular to the pin header. .