



Chipsmall Limited consists of a professional team with an average of over 10 year of expertise in the distribution of electronic components. Based in Hongkong, we have already established firm and mutual-benefit business relationships with customers from,Europe,America and south Asia,supplying obsolete and hard-to-find components to meet their specific needs.

With the principle of “Quality Parts,Customers Priority,Honest Operation,and Considerate Service”,our business mainly focus on the distribution of electronic components. Line cards we deal with include Microchip,ALPS,ROHM,Xilinx,Pulse,ON,Everlight and Freescale. Main products comprise IC,Modules,Potentiometer,IC Socket,Relay,Connector.Our parts cover such applications as commercial,industrial, and automotives areas.

We are looking forward to setting up business relationship with you and hope to provide you with the best service and solution. Let us make a better world for our industry!



Contact us

Tel: +86-755-8981 8866 Fax: +86-755-8427 6832

Email & Skype: info@chipsmall.com Web: www.chipsmall.com

Address: A1208, Overseas Decoration Building, #122 Zhenhua RD., Futian, Shenzhen, China



PmodOD1™ Reference Manual

Revised March 30, 2015

This manual applies to the PmodOD1 rev. A

Overview

The Digiilent PmodOD1 uses open-drain MOSFETs to drive high current applications.

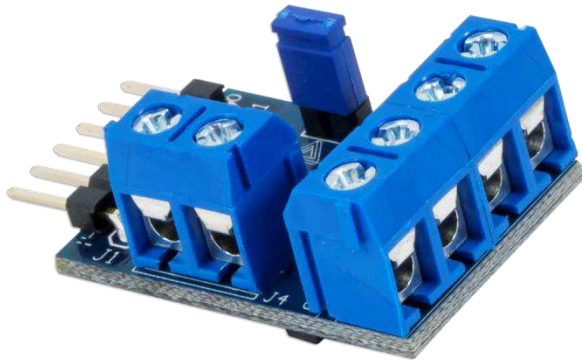

The PmodOD1.

Features include:

- Two [NTHD4508](#) dual power N-Channel ChipFET™s ¹⁾
- 4.1A peak output current ($t < 5s$)
- 3.0A continuous current (at 25°C)
- 20V max. output voltage

1 Functional Description

The PmodOD1 utilizes two NTHD4508 dual power N-FETs. Each channel can comfortably drive 3.0 A of continuous current at 25°C and up to 4.1 A of current for under 5 seconds, making this Pmod ideal for high current applications that require a simple on/off switch mechanism.

2 Interfacing with the Pmod

The PmodOD1 communicates with the host board via the GPIO protocol. A logic high signal “turns on” a particular MOSFET and a logic low signal turns off the MOSFET.

Pin	Signal	Description
1	G1	Output 1
2	G2	Output 2
3	G3	Output 3
4	G4	Output 4
5	GND	Power Supply Ground
6	VCC	Positive Power Supply (3.3/5V)

Table 1. Pinout description table.

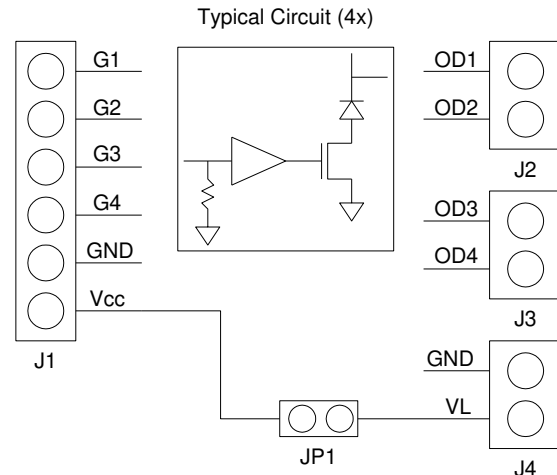

Figure 1. PmodOD1 block diagram.

Each output provides a clamp diode to prevent damage due to flyback voltages generated by inductive loads. Each output transistor functions independently of the others, so they can be used individually or simultaneously.

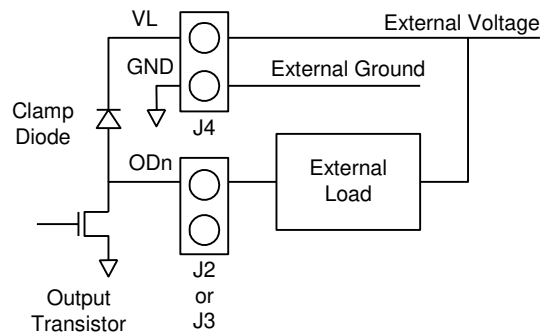

Figure 2. Output circuit with load connection.

As illustrated in Fig. 2, a load is connected so that current from an external voltage source conducts through the load to ground when the output transistor is turned on. In order to complete the circuit, the GND pin on J4 must be connected to the ground for the external voltage supply. Additionally, the external voltage source must be connected to the VL pin on J4 to complete the circuit for the output clamp diode.

Any external power applied to the PmodOD1 must be within 2.7V and 5.25V; however, it is recommended that Pmod is operated at 3.3V.

3 Physical Dimensions

The pins on the pin header are spaced 100 mil apart. The PCB is 1.15 inches long on the sides parallel to the pins on the pin header and 0.8 inches long on the sides perpendicular to the pin header.