



Chipsmall Limited consists of a professional team with an average of over 10 year of expertise in the distribution of electronic components. Based in Hongkong, we have already established firm and mutual-benefit business relationships with customers from,Europe,America and south Asia,supplying obsolete and hard-to-find components to meet their specific needs.

With the principle of “Quality Parts,Customers Priority,Honest Operation,and Considerate Service”,our business mainly focus on the distribution of electronic components. Line cards we deal with include Microchip,ALPS,ROHM,Xilinx,Pulse,ON,Everlight and Freescale. Main products comprise IC,Modules,Potentiometer,IC Socket,Relay,Connector.Our parts cover such applications as commercial,industrial, and automotives areas.

We are looking forward to setting up business relationship with you and hope to provide you with the best service and solution. Let us make a better world for our industry!



Contact us

Tel: +86-755-8981 8866 Fax: +86-755-8427 6832

Email & Skype: info@chipsmall.com Web: www.chipsmall.com

Address: A1208, Overseas Decoration Building, #122 Zhenhua RD., Futian, Shenzhen, China



ZedBoard

(Zynq™ Evaluation and Development) Hardware User's Guide

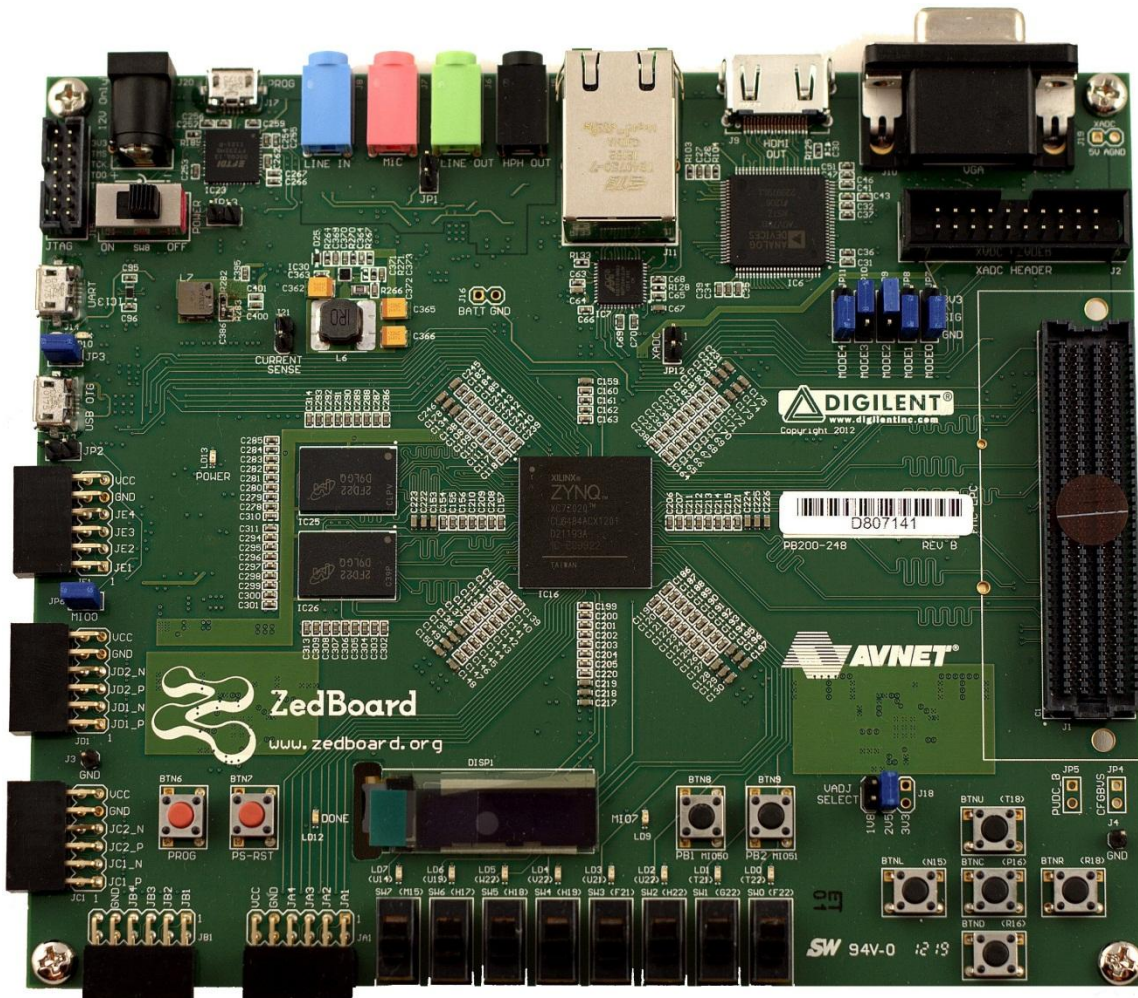

Version 1.1
August 1st, 2012

Revision History

Rev date	Rev #	Reason for change
8/1/12	1.0	Initial ZedBoard User's Guide
8/2/12	1.1	Mapped Configuration Mode Table to match ZedBoard layout

Table of Contents

1	INTRODUCTION.....	3
1.1	ZYNQ BANK PIN ASSIGNMENTS	5
2	FUNCTIONAL DESCRIPTION.....	6
2.1	EPP	6
2.2	MEMORY	6
2.2.1	DDR3.....	6
2.2.2	SPI Flash	9
2.2.3	SD Card Interface.....	11
2.3	USB	12
2.3.1	USB OTG.....	12
2.3.2	USB-to-UART Bridge	12
2.3.3	USB-JTAG	13
2.3.4	USB circuit protection	14
2.4	DISPLAY AND AUDIO.....	14
2.4.1	HDMI Output.....	14
2.4.2	VGA Connector.....	17
2.4.3	I2S Audio Codec	18
2.4.4	OLED.....	19
2.5	CLOCK SOURCES.....	19
2.6	RESET SOURCES	19
2.6.1	Power-on Reset (PS_POR_B).....	19
2.6.2	Program Push Button Switch.....	20
2.6.3	Processor Subsystem Reset.....	20
2.7	USER I/O	20
2.7.1	User Push Buttons	20
2.7.2	User DIP Switches.....	20
2.7.3	User LEDs	21
2.8	10/100/1000 ETHERNET PHY	21
2.9	EXPANSION HEADERS	22
2.9.1	LPC FMC Connector.....	22
2.9.2	Digilent Pmod™ Compatible Headers (2x6).....	23
2.9.3	Agile Mixed Signaling (AMS) Connector, J2.....	24
2.10	CONFIGURATION MODES	27
2.10.1	JTAG.....	28
2.11	POWER	29
2.11.1	Primary Power Input	29
2.11.2	On/Off Switch	29
2.11.3	Regulators.....	29
2.11.4	Sequencing.....	30
2.11.5	Power Good LED	31
2.11.6	Power Estimation	31
2.11.7	Testing	31
2.11.8	Probes.....	32
3	ZYNQ EPP BANKS.....	33
3.1	ZYNQ EPP BANK VOLTAGES.....	34
4	JUMPER SETTINGS	35
5	MECHANICAL	37

1 Introduction

The ZedBoard is an evaluation and development board based on the Xilinx Zynq-7000 Extensible Processing Platform. Combining a dual Corex-A9 Processing System (PS) with 85,000 Series-7 Programmable Logic (PL) cells, the Zynq-7000 EPP can be targeted for broad use in many applications. The ZedBoard's robust mix of on-board peripherals and expansion capabilities make it an ideal platform for both novice and experienced designers. The features provided by the ZedBoard consist of:

- Xilinx® XC7Z020-1CSG484CES EPP
 - Primary configuration = QSPI Flash
 - Auxiliary configuration options
 - Cascaded JTAG
 - SD Card
- Memory
 - 512 MB DDR3 (128M x 32)
 - 256 Mb QSPI Flash
- Interfaces
 - USB-JTAG Programming using Digilent SMT1-equivalent circuit
 - Accesses PL JTAG
 - PS JTAG pins connected through PS Pmod
 - 10/100/1G Ethernet
 - USB OTG 2.0
 - SD Card
 - USB 2.0 FS USB-UART bridge
 - Five Digilent Pmod™ compatible headers (2x6) (1 PS, 4 PL)
 - One LPC FMC
 - One AMS Header
 - Two Reset Buttons (1 PS, 1 PL)
 - Seven Push Buttons (2 PS, 5 PL)
 - Eight dip/slide switches (PL)
 - Nine User LEDs (1 PS, 8 PL)
 - DONE LED (PL)
- On-board Oscillators
 - 33.333 MHz (PS)
 - 100 MHz (PL)
- Display/Audio
 - HDMI Output
 - VGA (12-bit Color)
 - 128x32 OLED Display
 - Audio Line-in, Line-out, headphone, microphone
- Power
 - On/Off Switch
 - 12V @ 5A AC/DC regulator
- Software
 - ISE® WebPACK Design Software
 - License voucher for ChipScope™ Pro locked to XC7Z020

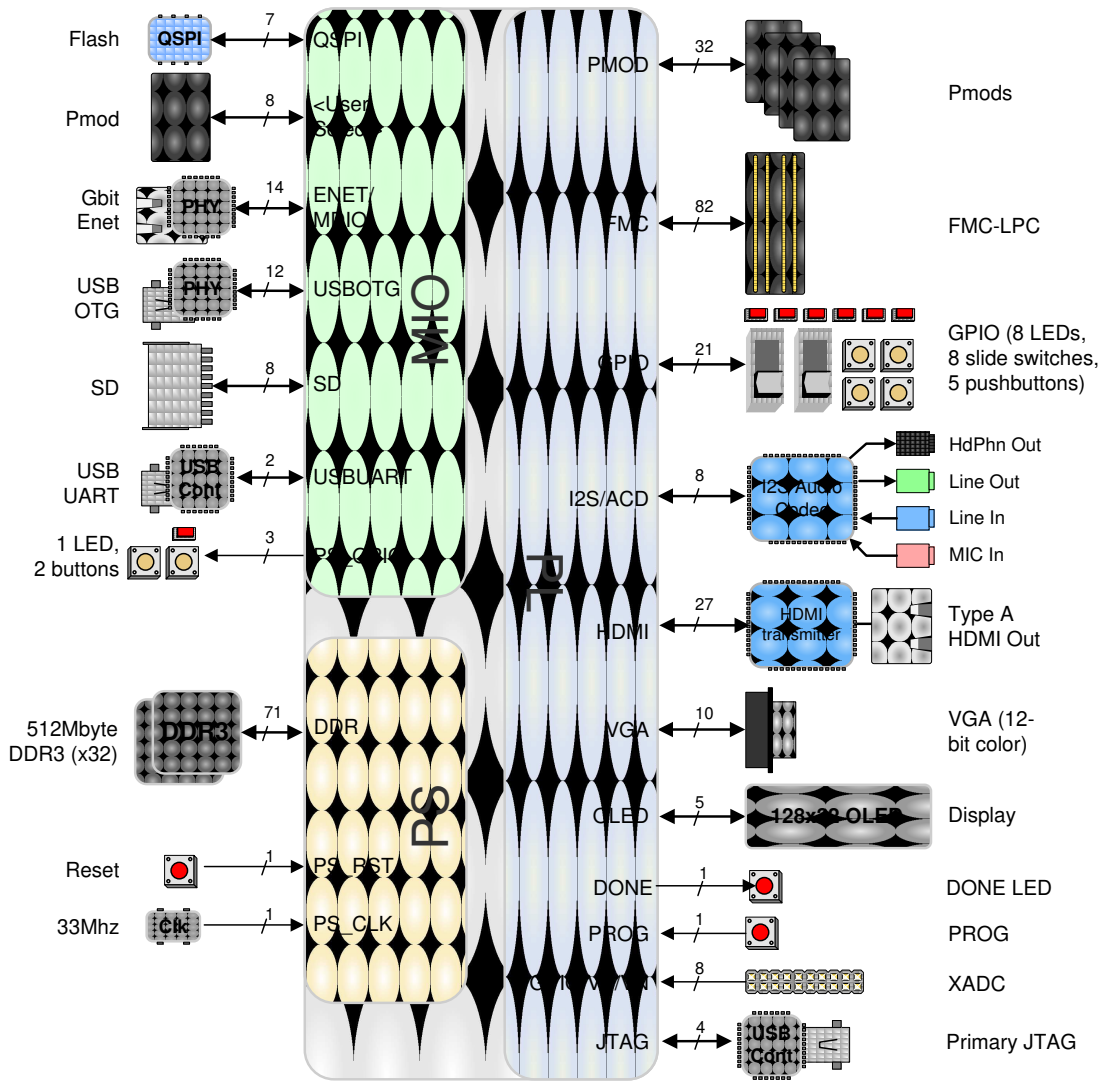

ZYNQ XC7Z020-CSG484

Figure 1 – ZedBoard Block Diagram

1.1 Zynq Bank Pin Assignments

The following figure shows the Zynq bank pin assignments on the ZedBoard followed by a table that shows the detailed I/O connections.

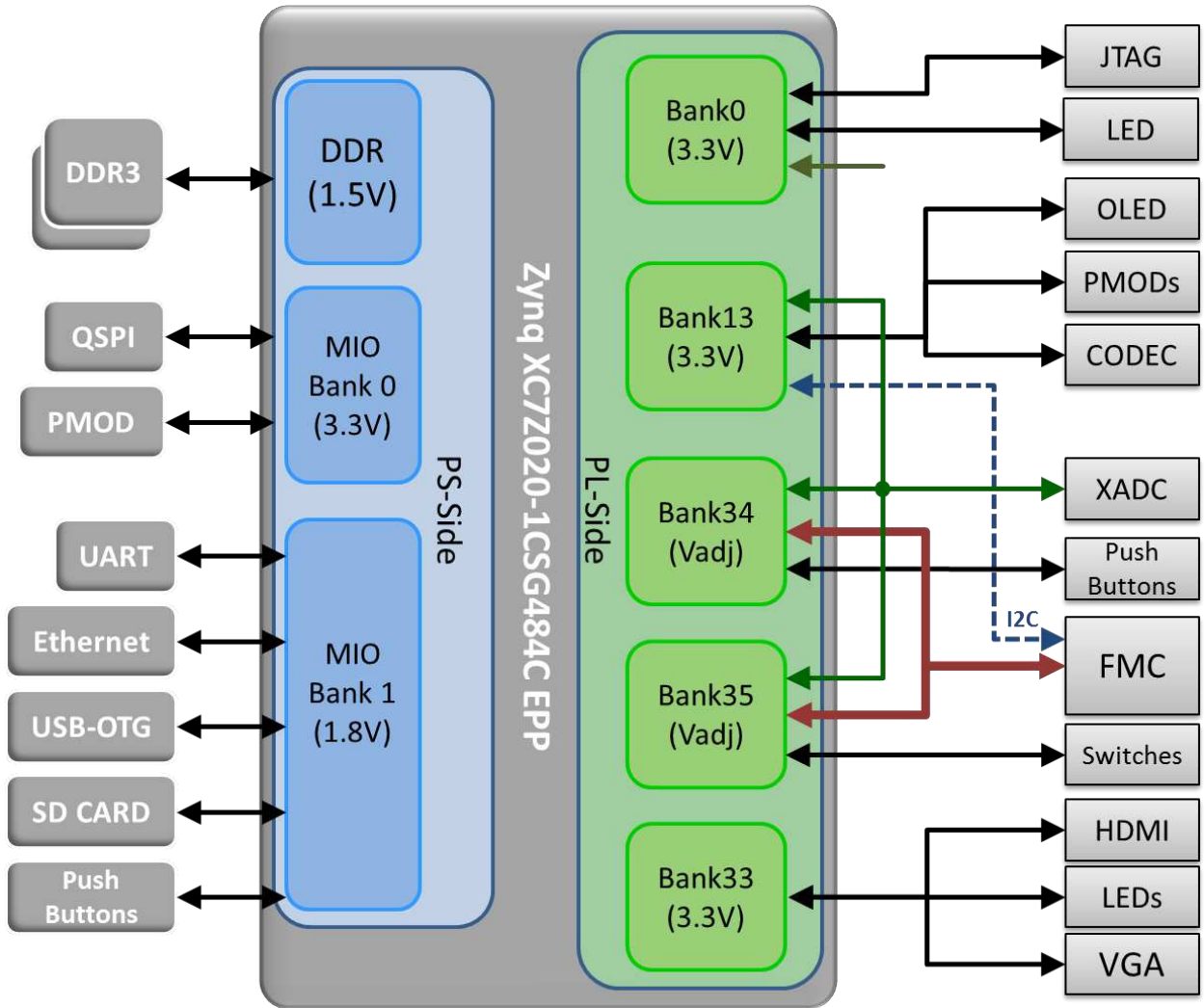

Figure 2 - Zynq Z7020 CSG484 Bank Assignments

2 Functional Description

2.1 EPP

The ZedBoard features a Xilinx Zynq XC7Z020-1CSG484 EPP. The initial ZedBoards ship with Engineering Sample "CES" grade silicon. Later shipments will eventually switch to production "C" grade silicon once they become available. The EPP part markings indicate the silicon grade.

2.2 Memory

Zynq contains a hardened PS memory interface unit. The memory interface unit includes a dynamic memory controller and static memory interface modules.

2.2.1 DDR3

The ZedBoard includes two Micron MT41K128M16HA-15E:D DDR3 memory components creating a 32-bit interface. The DDR3 is connected to the hard memory controller in the Processor Subsystem (PS) as outlined in the Zynq datasheet.

The multi-protocol DDR memory controller is configured for 32-bit wide accesses to a 512 MB address space. The PS incorporates both the DDR controller and the associated PHY, including its own set of dedicated I/Os. DDR3 memory interface speeds up to 533MHz (1066Mbs) are supported.

The DDR3 uses 1.5V SSTL-compatible inputs. DDR3 Termination is utilized on the ZedBoard. The EPP and DDR3 have been placed close together keeping traces short and matched.

DDR3 on the PS was routed with 40 ohm trace impedance for single-ended signals, and DCI resistors (VRP/VRN) as well as differential clocks set to 80 ohms. Each DDR3 chip needs its own 240-ohm pull-down on ZQ.

DDR-VDDQ is set to 1.5V to support the DDR3 devices selected. DDR-VTT is the termination voltage which is $\frac{1}{2}$ DDR-VDDQ. DDR-VREF is a separate buffered output that is equal to $\frac{1}{2}$ nominal DDR-VDDQ. The DDR-VREF is isolated to provide a cleaner reference for the DDR level transitions.

The PCB design guidelines outlined in Zynq datasheet must be followed for trace matching, etc.

Table 1 - DDR3 Connections

Signal Name	Description	Zynq EPP pin	DDR3 pin
DDR_CK_P	Differential clock output	N4	J7
DDR_CK_N	Differential clock output	N5	K7
DDR_CKE	Clock enable	V3	K9
DDR_CS_B	Chip select	P6	L2
DDR_RAS_B	RAS row address select	R5	J3
DDR_CAS_B	RAS column address select	P3	K3
DDR_WE_B	Write enable	R4	L3
DDR_BA[2:0]	Bank address	PS_DDR_BA[2:0]	BA[2:0]
DDR_A[14:0]	Address	PS_DDR_A[14:0]	A[14:0]
DDR_ODT	Output dynamic termination	P5	K1
DDR_RESET_B	Reset	F3	T2
DDR_DQ[31:0]	I/O Data	PS_DDR_[31:0]	DDR3_DQ pins
DDR_DM[3:0]	Data mask	PS_DDR_DM[3:0]	LDM/UDM x2
DDR_DQS_P[3:0]	I/O Differential data strobe	PS_DDR_DQS_P[3:0]	UDQS/LDQS
DDR_DQS_N[3:0]	I/O Differential data strobe	PS_DDR_DQS_N[3:0]	UDQS#/LDQS#
DDR_VRP	I/O Used to calibrate input termination	N7	N/A
DDR_VRN	I/O Used to calibrate input termination	M7	N/A
DDR_VREF[1:0]	I/O Reference voltage	H7, P7	H1

For best DDR3 performance, DRAM training is enabled for write leveling, read gate, and read data eye options in the PS Configuration Tool in Xilinx Platform Studio (XPS). The PS Configuration tools' Memory Configuration Wizard contains two entries to allow for DQS to Clock Delay and Board Delay information to be specified for each of the four byte lanes. These parameters are specific to every PCB design. [Xilinx Answer Record 46778](#) provides a tool for calculating these parameters by a printed circuit board design engineers. The Excel worksheet file **ar46778_board_delay_calc.xlsx** included in the answer record provides instructions in the worksheet for calculating these board training details based upon specific trace lengths for certain DDR3 signals. Using the information from the trace length reports pertaining to the DDR3 interface for ZedBoard these delay values can be recreated by following the directions found in the Excel worksheet.

The PCB lengths are contained in the ZedBoard PCB trace length reports. The DQS to CLK Delay and Board Delay values are calculated specific to the ZedBoard memory interface PCB design. The AR46778 worksheet allows for up to 4 memory devices to be configured for DDR3 4x8 flyby topology. Note that ZedBoard is configured for DDR3 2x16 flyby routing topology. The first two clock trace midpoint values (CLK0 and CLK1) are used to represent the Micron device electrically nearest to 7Z020 (IC26) and the second two clock trace midpoint values (CLK2 and

CLK3) are used to represent the Micron device electrically furthest from 7Z020 (IC25). The worksheet calculation results are shown in the following table.

Table 2 - DDR3 Worksheet Calculations

Pin Group	Length (mm)	Length (mils)	Package Length (mils)	Total Length (mils)	Propagation Delay (ps/inch)	Total Delay (ns)	DQS to CLK Delay (ns)	Board Delay (ns)
CLK0	55.77	2195.9	470	2665.9	160	0.427		
CLK1	55.77	2195.9	470	2665.9	160	0.427		
CLK2	41.43	1631.1	470	2101.1	160	0.336		
CLK3	41.43	1631.1	470	2101.1	160	0.336		
DQS0	51.00	2008.0	504	2512.0	160	0.402	0.025	
DQS1	50.77	1998.8	495	2493.8	160	0.399	0.028	
DQS2	41.59	1637.6	520	2157.6	160	0.345	-0.009	
DQS3	41.90	1649.4	835	2484.4	160	0.398	-0.061	
DQ[7:0]	50.63	1993.3	465	2458.3	160	0.393		0.410
DQ[15:8]	50.71	1996.4	480	2476.4	160	0.396		0.411
DQ[23:16]	40.89	1609.9	550	2159.9	160	0.346		0.341
DQ[31:24]	40.58	1597.8	780	2377.8	160	0.380		0.358

The DQS to CLK Delay fields in the PS7 DDR Configuration window should be populated using the corresponding values from the previous table.

The configuration fields of the tool may not allow you to input a negative delay value, this is a known problem with the 14.1 tools and scheduled for correction in the 14.2 tools release. In the case of DQS2 and DQS3 fields for DQS to CLK Delay, simply enter a value of zero rather than the negative delay values. This is an acceptable workaround since the calculated values are relatively close to zero and the values provided in these fields are used as initial values for the read/write training for DDR3. Keep in mind for LPDDR2 there is no write leveling, and for DDR2 there is no training whatsoever. In these memory use cases, the accuracy of the trace length info is more important. This is covered in further detail in section 10.6.8 of the [Xilinx Zynq TRM, UG585](#).

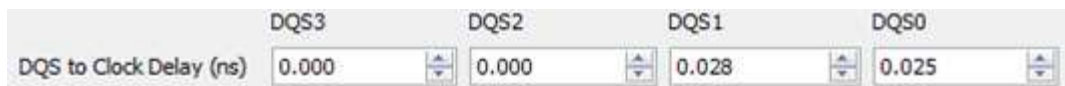

Figure 3 - DQS to Clock Delay Settings

The Board Delay fields in the PS7 DDR Configuration window should be populated using the corresponding values from the table above.

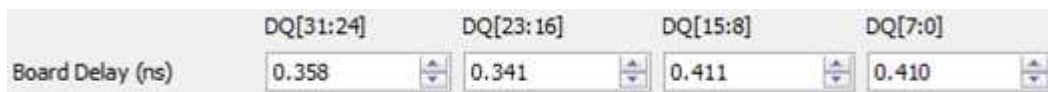

Figure 4 - DDR3 Board Delay Settings

2.2.2 SPI Flash

The ZedBoard features a 4-bit SPI (quad-SPI) serial NOR flash. The Spansion S25FL256S is used on this board. The Multi-I/O SPI Flash memory is used to provide non-volatile code, and data storage. It can be used to initialize the PS subsystem as well as configure the PL subsystem (bitstream). Spansion provides Spansion Flash File System (FFS) for use after booting the Zynq EPP.

The relevant device attributes are:

- 256Mbit
- x1, x2, and x4 support
- Speeds up to 104 MHz, supporting Zynq configuration rates @ 100 MHz
 - In Quad-SPI mode, this translates to 400Mbs
- Powered from 3.3V

The SPI Flash connects to the EPP supporting up to Quad-I/O SPI interface. This requires connection to specific pins in MIO Bank 0/500, specifically MIO[1:6,8] as outlined in the Zynq datasheet. Quad-SPI feedback mode is used, thus `qspi_sclk_fb_out/MIO[8]` is connected to a 20K pull-up resistor to 3.3V. This allows a QSPI clock frequency greater than FQSPICLK2.

Note: Zynq only supports 24-bit addressing, however the full capacity of the 256Mb Flash can be accessed via internal bank switching. As of now the S25FL256S is not supported in iMPACT.

Note: 14.x is required for in-direct QSPI Flash Programming.

Table 3 – QSPI Flash Pin Assignment and Definitions

Signal Name	Description	Zynq EPP Pin	QSPI Pin
DQ0	Data0	A2 (Bank MIO0/500)	5
DQ1	Data1	F6 (MIO Bank 0/500)	2
DQ2	Data2	E4 (MIO Bank 0/500)	3
DQ3	Data3	A3 (MIO Bank 0/500)	7
SCK	Serial Data Clock	A4 (MIO Bank 0/500)	6
CS	Chip Select	A1 (MIO Bank 0/500)	1
FB Clock	QSPI Feedback	E5 (MIO Bank 0/500)	N/C

Note: The QSPI data and clock pins are shared with the Boot Mode jumpers.

Two packages can be used on the ZedBoard; SO-16 and WSON. For the WSON package, there is a heat sink slug under the package that is not connected to any signal on the PCB.

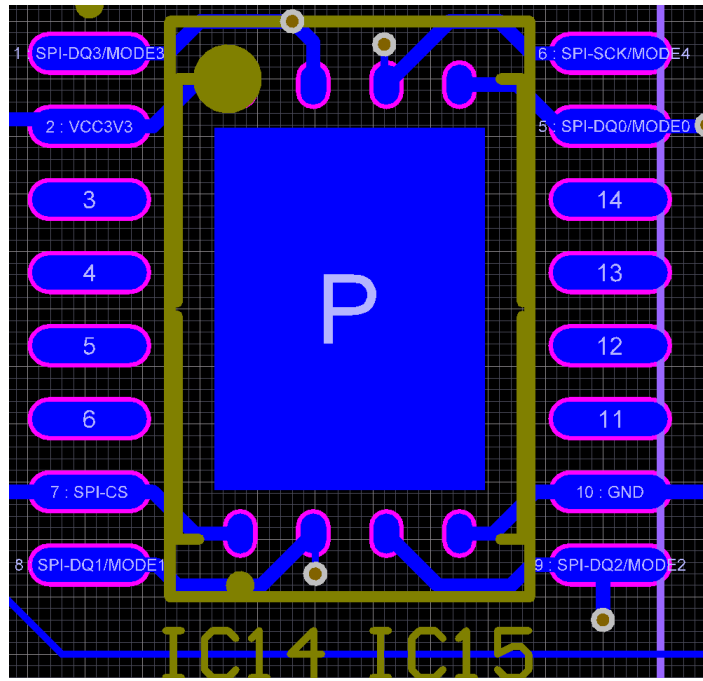

Figure 5 - Overlying Packages for SPI Flash

2.2.3 SD Card Interface

The Zynq PS SD/SDIO peripheral controls communication with the ZedBoard SD Card (A 4GB Class 4 card is included in the ZedBoard kit.) The SD card can be used for non-volatile external memory storage as well as booting the Zynq EPP. PS peripheral sd0 is connected through Bank 1/501 MIO[40-47], including, Card Detect and Write Protect.

The SD Card is a 3.3V interface but is connected through MIO Bank 1/501 (1.8V). Therefore, a TI TXS02612 level shifter performs this translation. The TXS02612 is a 2-port SDIO port expander with level translation. ZedBoard only makes use of one of these parts. TI offered an alternative TXS0206 device, but the 0.4mm pitch of that device's packaging was too fine for our manufacturer.

Based on the Zynq TRM, host mode is the only mode supported.

The ZedBoard SD Card is connected through a 9-pin standard SD card connector, J12, TE [2041021-1](http://www.te.com/2041021-1). A Class 4 card or better is recommended.

Note: To use the SD Card, JP6 must be shorted.

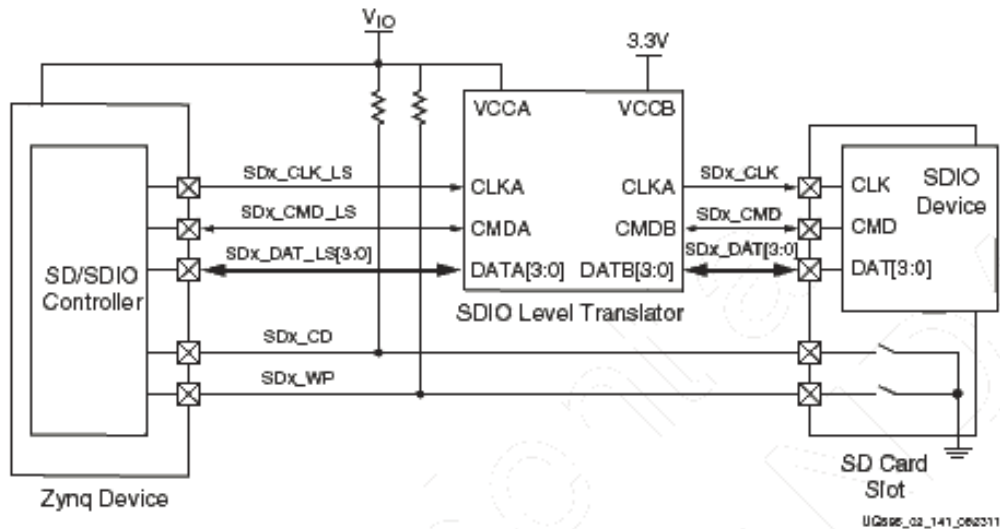

Figure 6 - SD Card Interface

Table 4 – SD Card Pin Assignment and Definitions

Signal Name	Description	Zynq EPP Pin	Level Shift Pin	SD Card Pin
CLK	Clock	E14 (MIO Bank 1/501)	Pass-Thru	5
CMD	Command	C8 ((MIO Bank 1/501)	Pass-Thru	2
Data[3:0]	Data	MIO Bank 1/501 D0: D8 D1: B11 D2: E13 D3: B9	Pass-Thru	Data Pins 7 8 9 1
CD	Card Detect	B10 (MIO Bank 1/501)	Pass-Thru	CD
WP	Write Protect	D12 ((MIO Bank 1/501)	Pass-Thru	WP

2.3 USB

2.3.1 USB OTG

ZedBoard implements one of the two available PS USB OTG interfaces. An external PHY with an 8-bit ULPI interface is required. A TI TUSB1210 Standalone USB Transceiver Chip is used as the PHY. The PHY features a complete HS-USB Physical Front-End supporting speeds of up to 480Mbps. This part is available in a 32-pin QFN package. VCCio for this device is 1.8V and cannot be connected through level shifters. The PHY is connected to MIO Bank 1/501, which is powered at 1.8V. Additionally the USB chip must clock the ULPI interface which requires an oscillator. A Fox XPRESSO oscillator (767-26-31) is used on ZedBoard.

The external USB interface connects through a TE [1981584-1](#).

The usb0 peripheral is used on the PS, connected through MIO[28-39] in MIO Bank 1/501.

This USB port will not power the board. However, ZedBoard provides 5V when in Host or OTG modes. REFCLK pin of TUSB1210 is tied to ground as the EPP will drive the CLOCK input of this part.

Table 5 - USB OTG Pin Assignment and Definitions

Signal Name	Description	Zynq EPP Pin	TUSB1210 Pin	USB Conn Pin
OTG_Data[8:0]	USB Data lines	MIO Bank 1/501	Data[7:0]	N/C
OTG_CLOCK	USB Clock	MIO Bank 1/501	26	N/C
OTG_DIR	ULPI DIR output signal	MIO Bank 1/501	31	N/C
OTG_STP	ULPI STP input signal	MIO Bank 1/501	29	N/C
OTG_NXT	ULPI NXT output signal	MIO Bank 1/501	2	N/C
OTG_CS	USB Chip Select		11	N/C
DP	DP pin of USB Connector	N/C	18	2
DM	DM pin of USB Connector	N/C	19	3
ID	Identification pin of the USB connector	N/C	23	4
OTG_RESET_B	Reset	MIO Bank 1/501	27	N/C
OTG_VBUS_OC	VBus Output Control	Bank 34	L16	TPS2051

See the Jumper Settings section for configuring the USB interface for Host, Device and OTG mode. The jumpers control the Vbus supply as well.

2.3.2 USB-to-UART Bridge

The ZedBoard implements a USB-to-UART bridge connected to a PS UART peripheral. A Cypress CY7C64225 USB-to-UART Bridge device allows connection to a host computer. The USB/UART device connects to the USB Micro B connector, J14, (TE 1981584-1) on the board. Only basic TXD/RXD connection is implemented. If flow control is required this can be added through Extended MIO on a PL-Pmod™.

Cypress provides royalty-free Virtual COM Port (VCP) drivers which permit the CY7C64225 USB-to-UART bridge to appear as a COM port to host computer communications application software (for example, HyperTerm or TeraTerm). Please refer to the CY7C64225 Setup Guide posted on zedboard.org for detailed instructions for installing the driver.

The UART 1 Zynq PS peripheral is accessed through MIO[48:49] in MIO Bank 1/501 (1.8V). Since the CY7C64225 device requires either 3.3V or 5V signaling, a TI TXS0102 level shifter is used to level shift between 3.3V and 1.8V.

This USB port will not power the board. Therefore, Vbus needs to be connected to 3.3V through a 1K Ω series resistor. The Wake pin, pin 22, connects to GND. A 24 Ω series resistor was placed on each of the data lines, D+ and D-.

Table 6 – CY7C6 Connections

EPP Pin	UART Function in EPP	Schematic Net Name	CY7C6 Pin	UART Function in CY7C64225
D11 (MIO Bank 1/501)	TX, data out	USB_1_RXD	23	RXD, data in
C14 (MIO Bank 1/501)	RX, data in	USB_1_TXD	4	TXD, data out

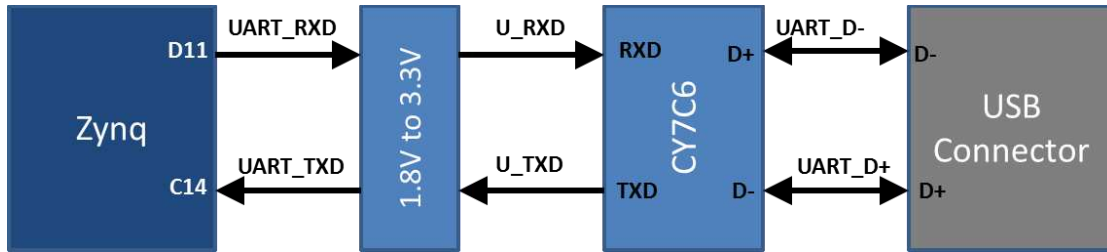

Figure 7 – USB-UART Bridge Interface

2.3.3 USB-JTAG

The ZedBoard provides JTAG functionality based on the Digilent USB High Speed JTAG Module, SMT1 device. This USB-JTAG circuitry is fully supported and integrated into Xilinx ISE tools, including iMPACT, ChipScope, and SDK Debugger. Designers who want to re-use this circuit on their board can do so by acquiring these modules from Avnet.

<http://www.em.avnet.com/en-us/design/drc/Pages/Digilent-JTAG-SMT1-Surface-Mount-Programming-Module.aspx>

The JTAG is available through a Micro B USB connector, J17, TE [1981568-1](#). TCK has a series termination resistor, 20-30 Ω , to prevent signal integrity issues.

For the JTAG Chain setup, please refer to the Configuration section.

2.3.4 USB circuit protection

All USB data lines, D+/-, are protected with a TE SESD0402Q2UG-0020-090.

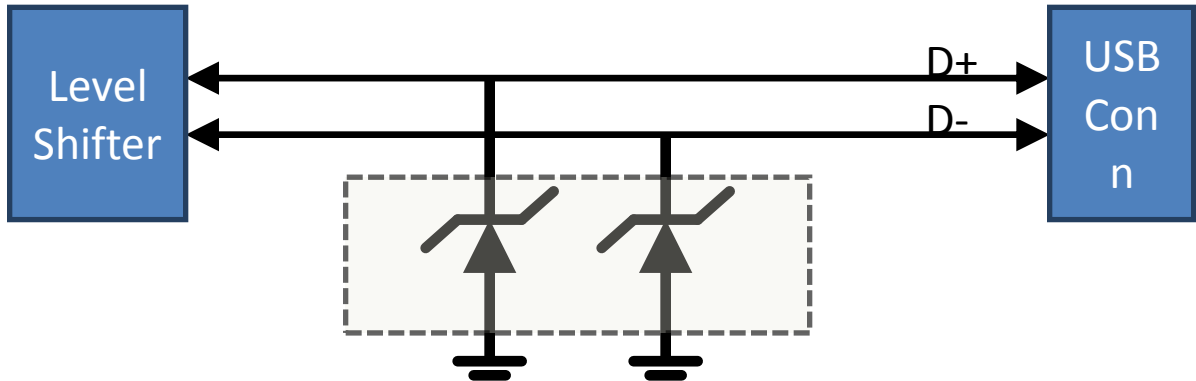

Figure 8 – ESD Protection

2.4 Display and Audio

2.4.1 HDMI Output

An Analog Devices ADV7511 HDMI Transmitter provides a digital video interface to the ZedBoard. This 225MHz transmitter is HDMI 1.4- and DVI 1.0-compatible supporting 1080p60 with 16-bit, YCbCr, 4:2:2 mode color.

The ADV7511 supports both S/PDIF and 8-channel I2S audio. The S/PDIF can carry compressed audio including Dolby® Digital, DTS®, and THX®. There is an independent DPDIF input and output. The I2S interface is not connected on ZedBoard. Analog Devices offers Linux drivers and reference designs illustrating how to interface to this device.

The HDMI Transmitter has 25 connections to Bank 35 (3.3V) of the EPP:

Table 7 - HDMI Interface Connections

Signal Name	Description	Zynq EPP pin	ADV7511 pin
HDP	Hot Plug Detect signal input	N/C	30
HD-INT	Interrupt signal output	W16	45
HD-SCL	I2C Interface. Supports CMOS logic levels from 1.8V to 3.3V	AA18	55
HD-SDA		Y16	56
HD-CLK	Video Clock Input. Supports typical CMOS logic levels from 1.8V up to 3.3V	W18	79
HD-VSYNC	Vertical Sync Input (Not required if using embedded syncs)	W17	2
HD-HSYNC	Horizontal Sync Input (Not required if using embedded syncs)	V17	98
HD-DE	Data Enable signal input for Digital Video (Not required if using embedded syncs)	U16	97
HD_D[15:0]	Video Data Input	Bank 35 D0: Y13 D1: AA12 D2: AA14 D3: Y14 D4: AB15 D5: AB16 D6: AA16 D7: AB17 D8: AA17 D9: Y15 D10: W13 D11: W15 D12: V15 D13: U17 D14: V14 D15: V13	88 87 86 85 84 83 82 81 80 78 74 73 72 71 70 69
HD-SPDIF	Sony/Philips Digital Interface Audio Input	U15	10
HD-SPDIFO	Sony/Philips Digital Interface Audio Output	Y18	46

Figure 2 Timing for Video Data Interface

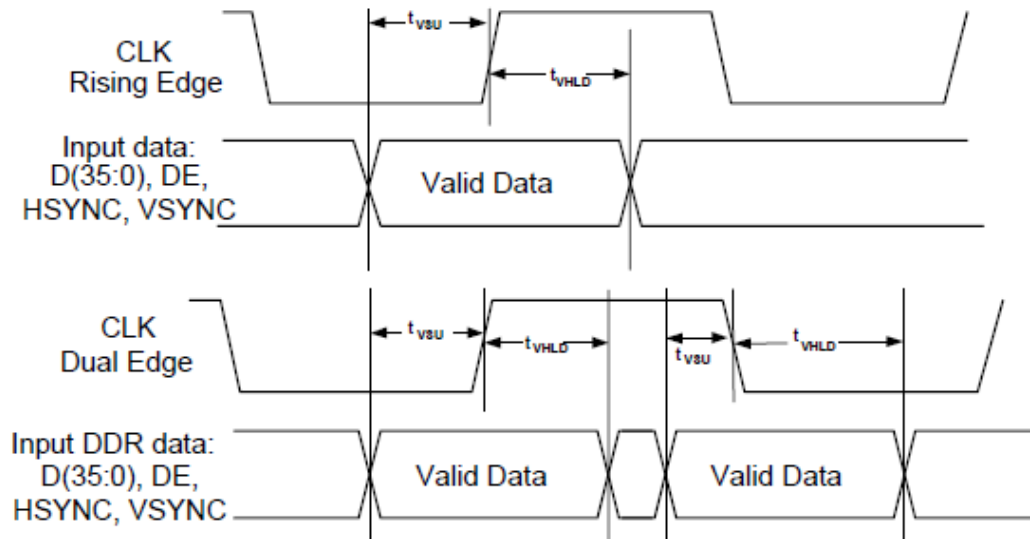

Figure 9 - HDMI Video Interface Timing

The HDMI transmitter connects externally via a HDMI Type A connector, J9, TE [1903015-1](#).

Circuit protection for the HDMI interface is provided by a Tyco Electronics SESD0802Q4UG.

2.4.2 VGA Connector

The ZedBoard also allows 12-bit color video output through a through-hole VGA connector, TE [4-1734682-2](#). Each color is created from resistor-ladder from four PL pins.

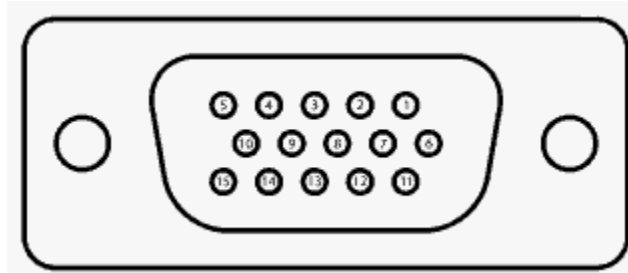

Figure 10 - DB15

Table 8 - VGA Connections

VGA Pin	Signal	Description	EPP Pin
1	RED	Red video	V20, U20, V19, V18
2	GREEN	Green video	AB22, AA22, AB21, AA21
3	BLUE	Blue video	Y21, Y20, AB20, AB19
4	ID2/RES	formerly Monitor ID bit 2	NC
5	GND	Ground (HSync)	NC
6	RED_RTN	Red return	NC
7	GREEN_RTN	Green return	NC
8	BLUE_RTN	Blue return	NC
9	KEY/PWR	formerly key	NC
10	GND	Ground (VSync)	NC
11	ID0/RES	formerly Monitor ID bit 0	NC
12	ID1/SDA	formerly Monitor ID bit 1	NC
13	HSync	Horizontal sync	AA19
14	VSync	Vertical sync	Y19
15	ID3/SCL	formerly Monitor ID bit 3	NC

2.4.3 I2S Audio Codec

An Analog Devices ADAU1761 Audio Codec provides integrated digital audio processing to the EPP. It allows for stereo 48KHz record and playback. Sample rates from 8KHz to 96KHz are supported. Additionally, the ADAU1761 provides digital volume control. The Codec can be configured using Analog Devices SigmaStudio™ for optimizing audio for specific acoustics, numerous filters, algorithms and enhancements. Analog Devices provides Linux drivers for this device.

http://www.analog.com/en/content/cu_over_sigmastudio_graphical_dev_tool_overview/fca.html

The Codec interface to the EPP consists of the following connections:

Table 9 - CODEC Connections

Signal Name	Description	Zynq EPP pin	ADAU1761 pin
AC-ADR0	I2C Address Bit 0/SPI Latch Signal	AB1	3
AC-ADR1	I2C Address Bit 1/SPI Data Input	Y5	30
AC-MCLK	Master Clock Input	AB2	2
AC-GPIO2	Digital Audio Bit Clock Input/Output	AA6	28
AC-GPIO3	Digital Audio Left-Right Clock Input/Output	Y6	29
AC-GPIO0	Digital Audio Serial-Data DAC Input	Y8	27
AC-GPIO1	Digital Audio Serial Data ADC Output	AA7	26
AC-SDA	I2C Serial Data interface	AB5	31
AC-SCK	I2C Serial Data interface	AB4	32

The Codec connects to the following connectors:

Table 10 - External Codec Connections

3.5mm Audio (Mic In) Pink	TE	1734152-5
3.5mm Audio (Line In) Light Blue	TE	1734152-6
3.5mm Audio (Line Out) Lime	TE	1734152-4
3.5mm Audio (Headphone) Black	TE	1734152-7

2.4.4 OLED

An Inteltronic/Wisechip UG-2832HSWEG04 OLED Display is used on the ZedBoard. This provides a 128x32 pixel, passive-matrix, monochrome display. The display size is 30mm x 11.5mm x 1.45mm.

Table 11 - OLED Connections

Pin Number	Symbol	EPP Pin	Function
Power Supply			
7	VDD	U12	<i>Power Supply for Logic</i>
6	VSS	N/C	<i>Ground of OEL System</i>
15	VCC	N/C	<i>Power Supply for OEL Panel</i>
Driver			
13	IREF	N/C	<i>Current Reference for Brightness Adjustment</i>
14	VCOMH	N/C	<i>Voltage Output High Level for COM Signal</i>
DC/DC Converter			
5	VBAT	U11	<i>Power Supply for DC/DC Converter Circuit</i>
3 / 4 1 / 2	C1P / C1N C2P / C2N	N/C	<i>Positive Terminal of the Flying Inverting Capacitor Negative Terminal of the Flying Boost Capacitor</i>
Interface			
9	RES#	U9	<i>Power Reset for Controller and Driver</i>
8	CS#	N/C	<i>Chip Select – Pulled Down on Board</i>
10	D/C#	U10	<i>Data/Command Control</i>
11	SCLK	AB12	<i>Serial Clock Input Signal</i>
12	SDIN	AA12	<i>Serial Data Input Signal</i>

2.5 Clock sources

The EPP's PS subsystem uses a dedicated 33.3333 MHz clock source, IC18, Fox 767-33.333333-12, with series termination. The PS infrastructure can generate up to four PLL-based clocks for the PL system. An on-board 100 MHz oscillator, IC17, Fox 767-100-136, supplies the PL subsystem clock input on bank 13, pin Y9.

2.6 Reset Sources

2.6.1 Power-on Reset (PS_POR_B)

The Zynq PS supports external power-on reset signals. The power-on reset is the master reset of the entire chip. This signal resets every register in the device capable of being reset. ZedBoard drives this signal from a comparator that holds the system in reset until all power supplies are valid. Several other IC's on ZedBoard are reset by this signal as well.

2.6.2 Program Push Button Switch

A PROG push switch, BTN6, toggles EPP PROG_B. This initiates reconfiguring the PL-subsection by the processor.

2.6.3 Processor Subsystem Reset

Power-on reset, labeled PS_RST/BTN7, erases all debug configurations. The external system reset allows the user to reset all of the functional logic within the device without disturbing the debug environment. For example, the previous break points set by the user remain valid after system reset. Due to security concerns, system reset erases all memory content within the PS, including the OCM. The PL is also reset in system reset. System reset does not re-sample the boot mode strapping pins.

2.7 User I/O

2.7.1 User Push Buttons

The ZedBoard provides 7 user GPIO push buttons to the EPP; five on the PL-side and two on the PS-side.

Pull-downs provide a known default state, pushing each button connects to Vcco.

Table 12 - Push Button Connections

Signal Name	Subsection	Zynq EPP pin
BTNU	PL	T18
BTNR	PL	R18
BTND	PL	R16
BTNC	PL	P16
BTNL	PL	N15
PB1	PS	D13 (MIO 50)
PB2	PS	C10 (MIO 51)

2.7.2 User DIP Switches

The ZedBoard has eight user dip switches, SW0-SW7, providing user input. SPDT switches connect the I/O through a 10kΩ resistor to the VADJ voltage supply or GND.

Table 13 - DIP Switch Connections

Signal Name	Zynq EPP pin
SW0	F22
SW1	G22
SW2	H22
SW3	F21
SW4	H19
SW5	H18
SW6	H17
SW7	M15

2.7.3 User LEDs

The ZedBoard has eight user LEDs, LD0 – LD7. A logic high on the EPP I/O causes the LED to turn on. LED's are sourced from 3.3V banks through 390Ω resistors.

Table 14 - LED Connections

Signal Name	Zynq EPP pin
LD0	T22
LD1	T21
LD2	U22
LD3	U21
LD4	V22
LD5	W22
LD6	U19
LD7	U14

2.8 10/100/1000 Ethernet PHY

The ZedBoard implements a 10/100/1000 Ethernet port for network connection using a Marvell 88E1518 PHY. This part operates at 1.8V. The PHY connects to MIO Bank 1/501 (1.8V) and interfaces to the Zynq EPP via RGMII. The RJ-45 connector is a TE Connectivity PlanarMAG (1840808-7) featuring integrated, auto-wound magnetics that enhance performance, quality and reliability. The RJ-45 has two status indicator LEDs that indicate traffic and valid link state.

A high-level block diagram of one 10/100/1000 Ethernet interface is shown in the following figure.

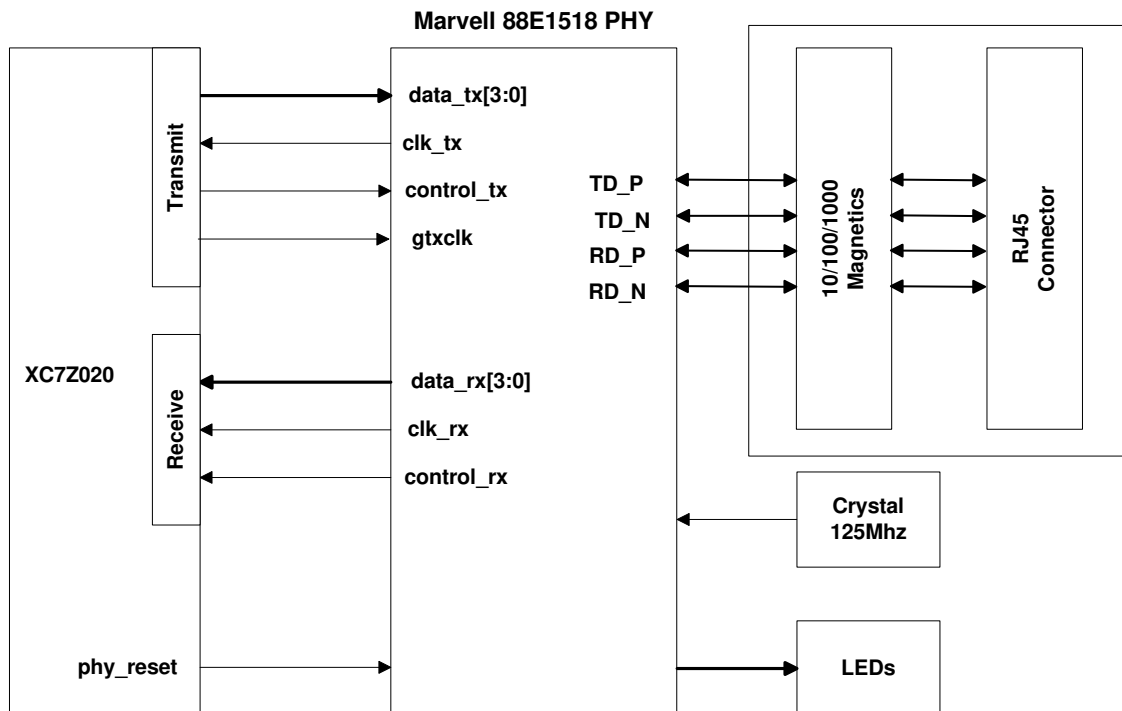

Figure 11 - 10/100/1000 Ethernet Interface

Zynq requires a voltage reference for RGMII interfaces. Thus PS_MIO_VREF, F8, is tied to 0.9V, half the bank voltage of MIO Bank 1/501.

Table 15 – Ethernet PHY Pin Assignment and Definitions

Signal Name	Description	Zynq EPP pin	88E1510 pin
RX_CLK	Receive Clock	A14	40
RX_CTRL	Receive Control	D7	37
RXD[3:0]	Receive Data	RXD0: E11	38
		RXD1: B7	39
		RXD2: F12	41
		RXD3: A13	42
TX_CLK	Transmit Clock	D6	47
TX_CTRL	Transmit Control	F11	2
TXD[3:0]	Transmit Data	TXD0: E9	44
		TXD1: A7	45
		TXD2: E10	48
		TXD3: A8	1
MDIO	Management Data	C12	5
MDC	Management Clock	D10	4

The datasheet for the Marvell 88E1518 is not available publicly. An NDA is required for this information. Please contact your local Avnet or Marvell representative for assistance.

2.9 Expansion Headers

2.9.1 LPC FMC Connector

A single low-pin count (LPC) FMC slot is provided on the ZedBoard to support a large ecosystem of plug-in modules. The LPC FMC exposes 68 single-ended I/O, which can be configured as 34 differential pairs. The FMC interface spans over two PL I/O banks, banks 34 and 35. To meet the FMC spec, these banks are powered from an adjustable voltage set by jumper, J18. Selectable voltages include 1.8V, default, and 2.5V. It is also possible to set Vadj to 3.3V. Since 3.3V could potentially be the most damaging voltage setting for Vadj, this is not available with the default board hardware. To set Vadj to 3.3V, solder a short across the 3V3 pads at J18 or solder in an additional 1x2 header.

WARNING: Before attaching a FMC Card, ensure the correct voltage is selected on jumper, J18. Failure to do so may result in damage to the FMC card and/or the ZedBoard.

Note, the following LPC FMC connections guidelines were followed:

- **CLK_#_M2C**
 - 50 ohm single-ended impedance
 - Less than 10mil skew in P/N pair
 - Connected to GC (Global Clock) preferential or MRCC (Multi-Region) if not available
 - No length matching to any other feature
- **LA bus**
 - 50 ohm single-ended impedance
 - Less than 10mil skew in P/N pair
 - Less than 100mil length skew across all bits in a bus
 - No restriction between LA, HA or HB
 - LA Bus 0:16 to be located in one bank
 - LA Bus 17:33 to be located in one bank
 - CC Pairs 0, 17 to be placed on MRCC pins
 - CC Pairs 1, 18 to be placed on SRCC pins
 - HB_06_CC optional placed on clock pin if available
- To conserve EPP pins, GA[1:0] were removed from EPP and connected to GND.

2.9.2 Digilent Pmod™ Compatible Headers (2x6)

The ZedBoard has five Digilent Pmod™ compatible headers (2x6). These are right-angle, 0.1” female headers that include eight user I/O plus 3.3V and ground signals as show in the figure below.

Four Pmod connectors interface to the PL-side of the EPP. These will connect to EPP Bank 13 (3.3V). One Pmod, JE1, connects to the PS-side of the EPP on MIO pins [7,9-15] in EPP MIO Bank 0/500 (3.3V). Uses for this Pmod include PJTAG access (MIO[10-13]) as well as nine other hardened MIO peripherals (SPI, GPIO, CAN, I2C, UART, SD, QSPI, Trace, Watchdog).

The four PL Pmod connectors are placed in adjacent pairs on the board edge such that the clearance between Pin 6 of header #1 and Pin 1 of header #2 is 10mm.

Two of the Pmods, JC1 and JD1, are aligned in a dual configuration and have their I/O routed differentially to support LVDS running at 525Mbs.

All Pmod data lines, 8 per connector, are protected with two 4-channel TE SESD1004Q4UG-0020-090.

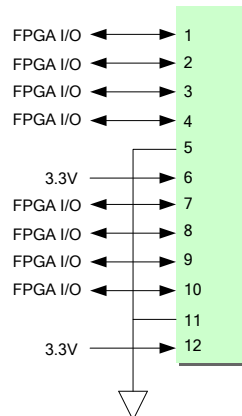

Figure 12 - Pmod Connections

A couple links to Pmod examples are provided:

- <http://www.em.avnet.com/en-us/design/drc/Pages/Digilent-PmodWiFi-802-11bgn-WiFi-Interface.aspx>
- <http://www.em.avnet.com/en-us/design/drc/Pages/Digilent-Pmod-RS232-Serial-Converter-and-Interface.aspx>

Table 16 - Pmod Connections

Pmod	Signal Name	Zynq EPP pin	Pmod	Signal Name	Zynq EPP pin
JA1	JA1	Y11	JB1	JB1	W12
	JA2	AA11		JB2	W11
	JA3	Y19		JB3	V10
	JA4	AA9		JB4	W8
	JA7	AB11		JB7	V12
	JA8	AB10		JB8	W10
	JA9	AB9		JB9	V9
	JA10	AA8		JB10	V8

Pmod	Signal Name	Zynq EPP pin	Pmod	Signal Name	Zynq EPP pin
JC1 Differential	JC1_N	AB6	JD1 Differential	JD1_N	W7
	JC1_P	AB7		JD1_P	V7
	JC2_N	AA4		JD2_N	V4
	JC2_P	Y4		JD2_P	V5
	JC3_N	T6		JD3_N	W5
	JC3_P	R6		JD3_P	W6
	JC4_N	U4		JD4_N	U5
	JC4_P	T4		JD4_P	U6

Pmod	Signal Name	Zynq EPP pin
JE1 MIO Pmod	JE1	A6
	JE2	G7
	JE3	B4
	JE4	C5
	JE7	G6
	JE8	C4
	JE9	B6
	JE10	E6

2.9.3 Agile Mixed Signaling (AMS) Connector, J2

The XADC header provides analog connectivity for analog reference designs, including AMS daughter cards like Xilinx’s AMS Evaluation Card.

The analog header is placed close to the LPC FMC header as shown. Both analog and digital IO can be easily supported for a plug in card. This allows the analog header to be easily connected to the FMC card using a short ribbon cable as shown. The analog header can also be used “stand alone” to support the connection of external analog signals.

The pin out has been chosen to provide tightly coupled differential analog pairs on the ribbon cable and to also provide AGND isolation between channels. The plug in cards which will facilitate a number of reference designs have not yet been designed so this pin out must provide a reasonable degree of freedom while also keeping resource requirements as minimal as possible.

The ZedBoard AMS header is comparable with similar connectors on the Xilinx KC705 and ZC702 boards. Any AMS plug-in cards built for those boards should be compatible with ZedBoard as well.