



Chipsmall Limited consists of a professional team with an average of over 10 year of expertise in the distribution of electronic components. Based in Hongkong, we have already established firm and mutual-benefit business relationships with customers from,Europe,America and south Asia,supplying obsolete and hard-to-find components to meet their specific needs.

With the principle of “Quality Parts,Customers Priority,Honest Operation,and Considerate Service”,our business mainly focus on the distribution of electronic components. Line cards we deal with include Microchip,ALPS,ROHM,Xilinx,Pulse,ON,Everlight and Freescale. Main products comprise IC,Modules,Potentiometer,IC Socket,Relay,Connector.Our parts cover such applications as commercial,industrial, and automotives areas.

We are looking forward to setting up business relationship with you and hope to provide you with the best service and solution. Let us make a better world for our industry!



Contact us

Tel: +86-755-8981 8866 Fax: +86-755-8427 6832

Email & Skype: info@chipsmall.com Web: www.chipsmall.com

Address: A1208, Overseas Decoration Building, #122 Zhenhua RD., Futian, Shenzhen, China



PART NAME: KNOB & SKIRT ASSEMBLY | SCALE: 1:1 | DATE: 2/25/57 | DR. BY LSP

DAVIES MOLDING COMPANY
CAROL STREAM, ILLINOIS 60188

P/N 4107AR

THIS DRAWING IS THE PROPERTY OF DAVIES MOLDING COMPANY, IS SUBMITTED SOLELY AS A DESIGN OR ENGINEERING PROJECT. WE ACCEPT NO RESPONSIBILITY WHATSOEVER FOR THE PRACTICAL APPLICATION OF THE PIECES MADE TO THIS DESIGN.

BASE PART 4101-01

SKIRT 4111AT

SCREWS I0375 (3)

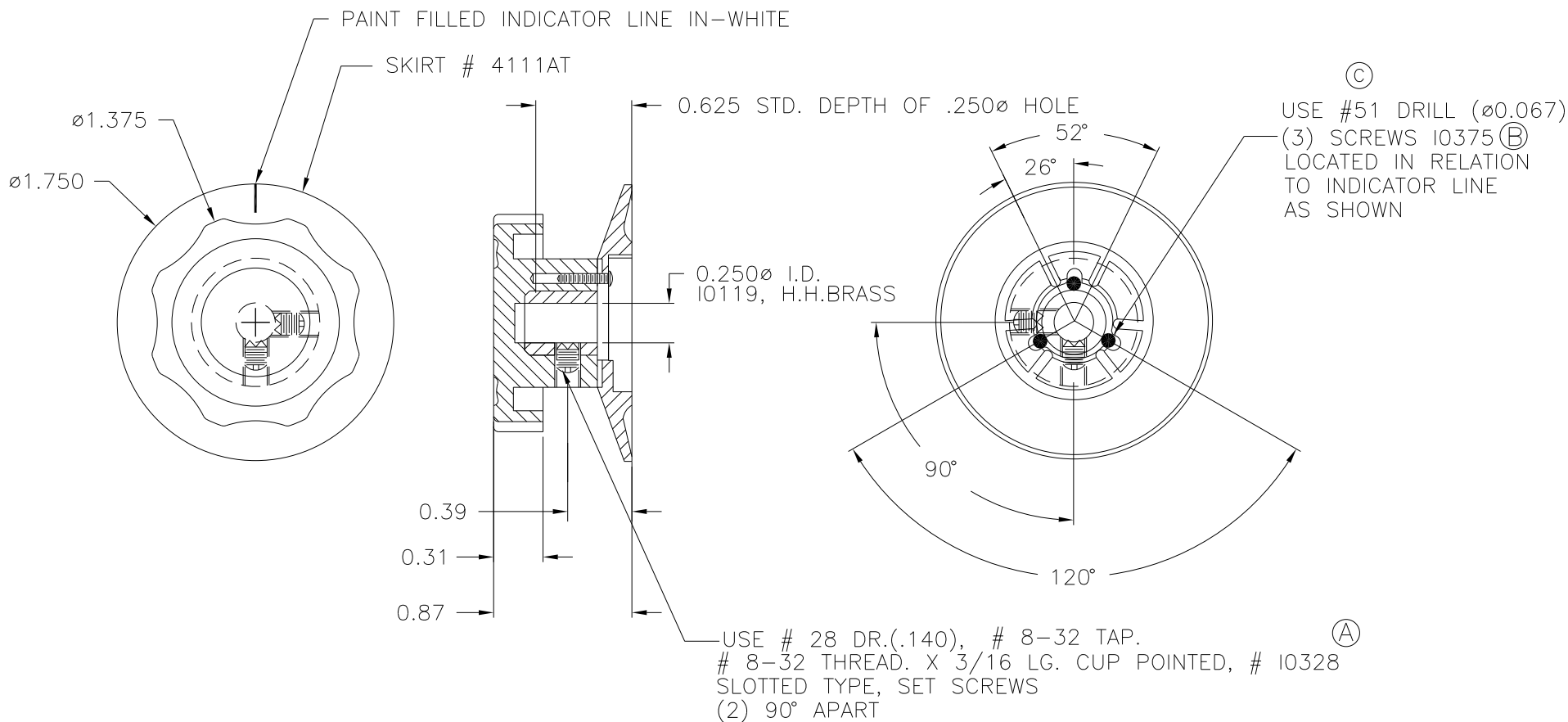

MATERIAL: G.P. PHENOLIC (B11)
COLOR: BLACK

TOLERANCES:
UNLESS OTHERWISE SPECIFIED

DO NOT SCALE
DRAWING

DECIMALS: X.XXX \pm .005
X.XX \pm .015

MM: X.XX \pm 0.15MM
X.X \pm 0.4MM

FRACTIONS \pm 1/64

ANG. \pm 1°

C	ADDED DRILL	JAM	2/5/14
-	UPDATED TOOLBOX	JAM	2/20/03
B	WAS I???	MH	1/08/99
A	ADDED I0328	MH	1/08/99
-	CAD/REDRAWN	HD	5/1/97

CHANGES