



Chipsmall Limited consists of a professional team with an average of over 10 year of expertise in the distribution of electronic components. Based in Hongkong, we have already established firm and mutual-benefit business relationships with customers from,Europe,America and south Asia,supplying obsolete and hard-to-find components to meet their specific needs.

With the principle of “Quality Parts,Customers Priority,Honest Operation,and Considerate Service”,our business mainly focus on the distribution of electronic components. Line cards we deal with include Microchip,ALPS,ROHM,Xilinx,Pulse,ON,Everlight and Freescale. Main products comprise IC,Modules,Potentiometer,IC Socket,Relay,Connector.Our parts cover such applications as commercial,industrial, and automotives areas.

We are looking forward to setting up business relationship with you and hope to provide you with the best service and solution. Let us make a better world for our industry!



Contact us

Tel: +86-755-8981 8866 Fax: +86-755-8427 6832

Email & Skype: info@chipsmall.com Web: www.chipsmall.com

Address: A1208, Overseas Decoration Building, #122 Zhenhua RD., Futian, Shenzhen, China



THIS DRAWING IS UNPUBLISHED. RELEASED FOR PUBLICATION
 © COPYRIGHT - By - ALL RIGHTS RESERVED.

LOC		DIST		REVISIONS			
P	LTR	DESCRIPTION		DATE	DWN	APVD	
AJ	16	J2	ECR-12-005726	27MAR12	RK	MY	

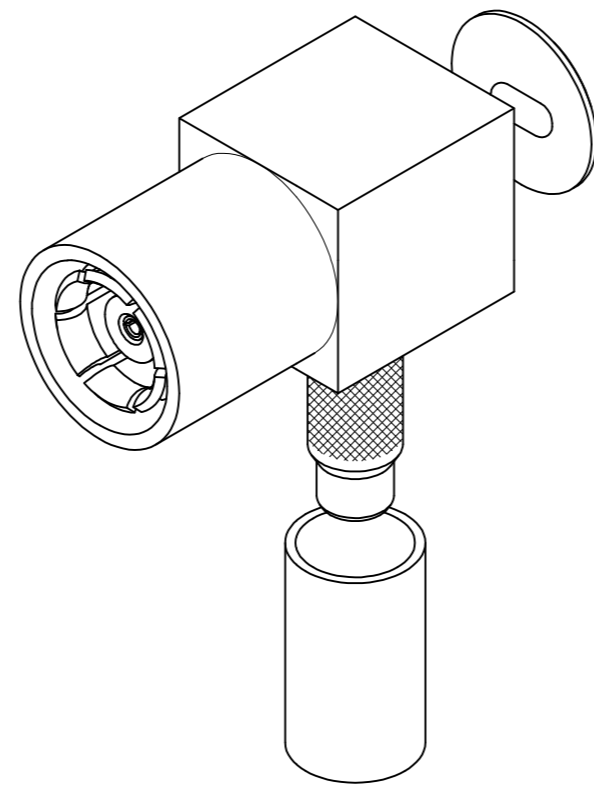
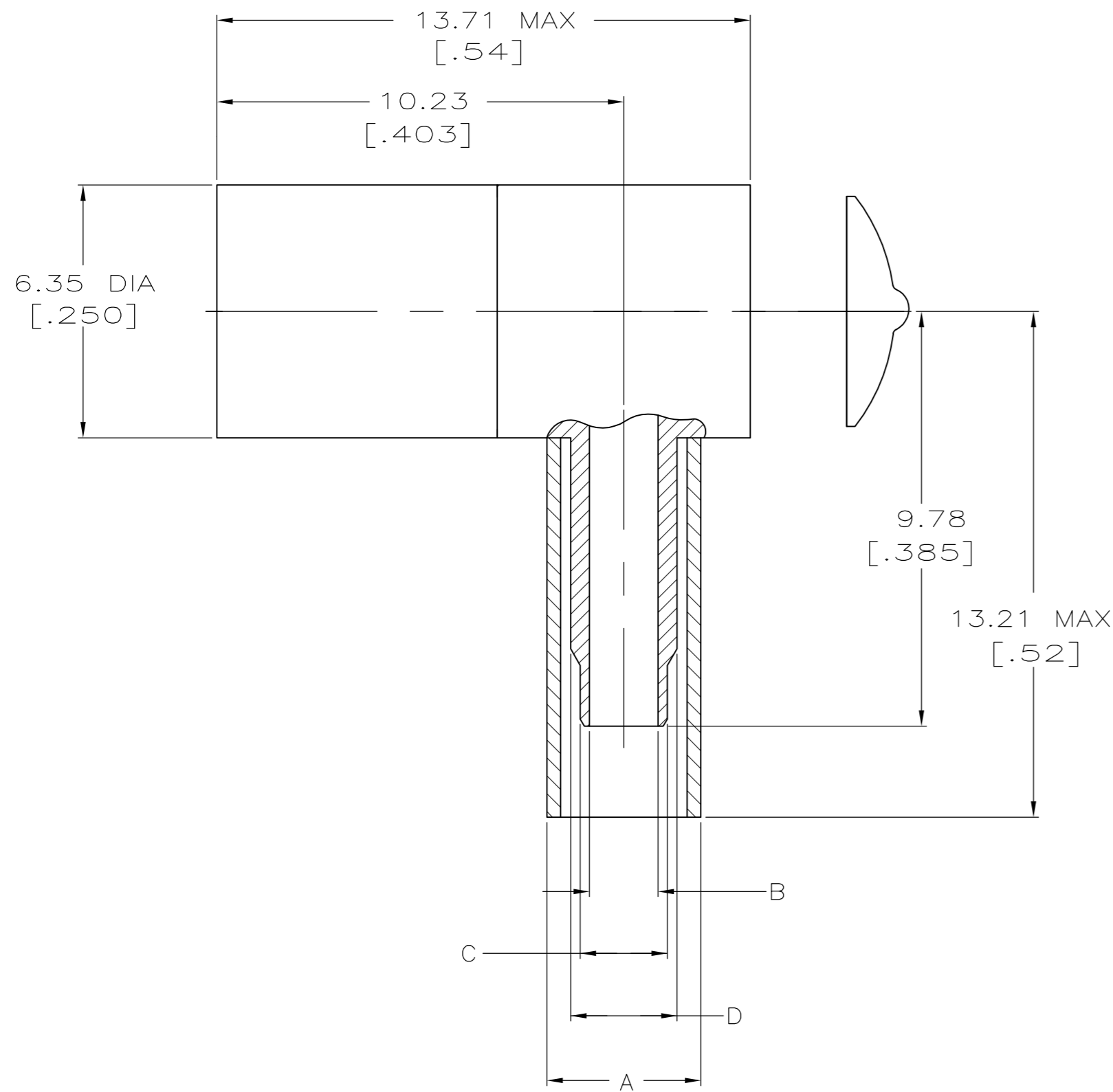

ISOMETRIC VIEW

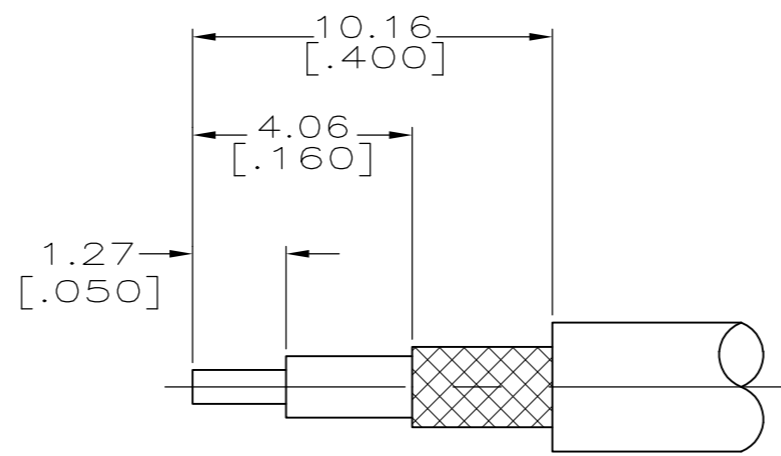

RECOMMENDED STRIP LENGTHS
SCALE NTS

- MATERIALS:
 BODY...BRASS PER QQ-B-626
 INNER AND OUTER CONTACTS...
 BERYLLIUM COPPER PER QQ-C-533
 DIELECTRIC...PTFE PER LP-403
- FINISH:
 BODY AND OUTER CONTACTS...
 GOLD PER MIL-G-45204 OVER
 NICKEL PER QQ-N-290.
 CENTER CONTACT...GOLD PER MIL-G-45204
 AT INTERFACE AND AT SOLDER END; OVER
 NICKEL PER QQ-N-290
- FINISH:
 BODY...NICKEL PER QQ-N-290 OVER
 COPPER PER MIL-C-14550
 OUTER CONTACTS...GOLD PER MIL-G-45204
 OVER NICKEL PER QQ-N-290
 CENTER CONTACT...GOLD PER MIL-G-45204
 AT INTERFACE AND AT SOLDER END; OVER
 NICKEL PER QQ-N-290
- FINISH:
 BODY AND OUTER CONTACT...NICKEL
 PER QQ-N-290 OVER COPPER PER
 MIL-C-14550
 CENTER CONTACT...GOLD PER MIL-C-45204
 AT INTERFACE AND AT SOLDER END; OVER
 NICKEL PER QQ-N-290
- INTERFACE PER MIL-C-39012.
- SEE I.S. SHEET 2987-9

SUPSD BY 414002-4	C	58483-1	.151	HX4-1637	2.64 [.104]	2.16 [.085]	1.70 [.067]	4.54 [.179]	3	RG 174,188,316(ALL DBL SHIELDED)	1-414002-0
	A	58483-1	.105	HX4-1637	1.98 [.076]	1.37 [.055]	0.96 [.040]	3.86 [.152]	4	RG 178,196	414002-9
SUPSD BY 414002-8	A	58483-1	.105	HX4-1637	1.98 [.076]	1.37 [.055]	0.96 [.040]	3.86 [.152]	3	RG 178,196	414002-8
	A	58483-1	.105	HX4-1637	1.98 [.076]	1.37 [.055]	0.96 [.040]	3.86 [.152]	2	RG 178,196	414002-7
SUPSD BY 414363-6	C	58483-1	.151	HX4-1637	2.64 [.104]	2.16 [.085]	1.70 [.067]	4.54 [.179]	4	RG 174,188,316(ALL DBL SHIELDED)	414002-6
	B	58483-1	.128	HX4-1637	2.64 [.104]	2.16 [.085]	1.70 [.067]	3.86 [.152]	4	RG 174,188,316	414002-5
	C	58483-1	.151	HX4-1637	2.64 [.104]	2.16 [.085]	1.70 [.067]	4.54 [.179]	3	RG 174,188,316(ALL DBL SHIELDED)	414002-4
	B	58483-1	.128	HX4-1637	2.64 [.104]	2.16 [.085]	1.70 [.067]	3.86 [.152]	3	RG 174,188,316	414002-3
	C	58483-1	.151	HX4-1637	2.64 [.104]	2.16 [.085]	1.70 [.067]	4.54 [.179]	2	RG 174,188,316(ALL DBL SHIELDED)	414002-2
	B	58483-1	.128	HX4-1637	2.64 [.104]	2.16 [.085]	1.70 [.067]	3.86 [.152]	2	RG 174,188,316	414002-1

POSITION LETTER	TE DIE SET	HEX SIZE	DANIELS DIE SET	D DIA	C DIA	B DIA	A DIA	NOTES	CABLE	PART NO
TE PRO-CRIMPER FOR BRAID CRIMP				M 22520/5-01 FOR BRAID CRIMP						

TOOLING INFORMATION

METRIC

THIS DRAWING IS A CONTROLLED DOCUMENT.		DWN	11/8/90	 TE Connectivity
DIMENSIONS: mm [INCHES]		CHK	11/8/90	
TOLERANCES UNLESS OTHERWISE SPECIFIED:		APVD	11/9/90	
0 PLC ± - 1 PLC ± - 2 PLC ± 0.25 [.010] 3 PLC ± 0.130 [.005] 4 PLC ± - ANGLES ± 1°		PRODUCT SPEC		
MATERIAL SEE NOTES		FINISH	SEE NOTES	NAME
		WEIGHT	-	PLUG,RTANG CRIMP,HEX CRIMP,SMB
		CUSTOMER DRAWING		SIZE
				CAGE CODE
				DRAWING NO
				RESTRICTED TO
				A2 00779 C-414002
				SCALE
				8:1
				SHEET
				1 OF 1
				REV
				J2