



Chipsmall Limited consists of a professional team with an average of over 10 year of expertise in the distribution of electronic components. Based in Hongkong, we have already established firm and mutual-benefit business relationships with customers from,Europe,America and south Asia,supplying obsolete and hard-to-find components to meet their specific needs.

With the principle of “Quality Parts,Customers Priority,Honest Operation,and Considerate Service”,our business mainly focus on the distribution of electronic components. Line cards we deal with include Microchip,ALPS,ROHM,Xilinx,Pulse,ON,Everlight and Freescale. Main products comprise IC,Modules,Potentiometer,IC Socket,Relay,Connector.Our parts cover such applications as commercial,industrial, and automotives areas.

We are looking forward to setting up business relationship with you and hope to provide you with the best service and solution. Let us make a better world for our industry!



Contact us

Tel: +86-755-8981 8866 Fax: +86-755-8427 6832

Email & Skype: info@chipsmall.com Web: www.chipsmall.com

Address: A1208, Overseas Decoration Building, #122 Zhenhua RD., Futian, Shenzhen, China



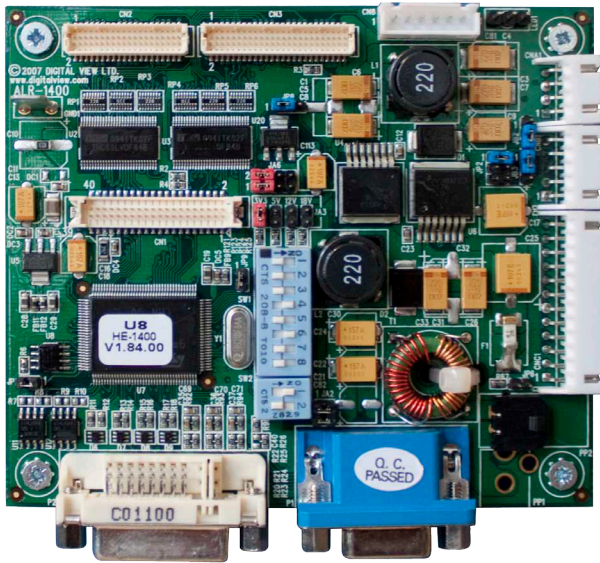

HE-1400

Harsh Environment LCD Controller Board

Key Features :

- > Low Power Consumption
- > Harsh Environment Features
- > DVI, VGA Inputs
- > VGA to WXGA Resolutions

The HE range of COTS controllers are designed to aid in compliance of the strict standards required for Harsh Environment applications. Featuring wide-tolerance power supplies ($\pm 25\%$), low mass tantalum capacitors for maximum vibration and shock tolerance, conformal coating, laboratory certified*** operating temperature range from -40°C to $+80^{\circ}\text{C}$, plus calculated MTBF in excess of 200K hours.

The HE-1400 is a small footprint, highly integrated controller with both DVI and ARGB inputs. Capable of supporting 4:3 format panels up to SXGA and 16:9 panels up to WXGA, the HE-1400 provides support for both LVDS and TTL panels.

Panel Connectivity

1366x768	1024x768	640x480
1280x1024	1024x600	480x234
1280x800	800x600	
1280x768	800x480	

Input

Analog RGB:	60Hz at SXGA, WXGA, XGA, SVGA, VGA
DVI-D:	60Hz at SXGA, WXGA, XGA, SVGA, VGA
	With auto detect of Digital Separate Sync, Sync-On-Green & Composite Sync. Auto detects VGA-SXGA, interlaced & non-interlaced.

Reliability

Calculated Mean Time Between Failures In excess of 200,000 hours.
Warranty: 3 years.

Custom Engineering Services

Custom input timing, panel timing, splash screen, OSD Menu, conformal coatings, layouts etc

Features

Colors :	Up to 8-bit per color, 16.7 million colors.
Functions :	On Screen Display (OSD) menu.
Function Controls :	External buttons, Serial Port Control.
Image Scaling :	Up scaling to fit input to panel resolution.
Image Control :	Brightness, Contrast, RGB adjust, Color Temperature
Other Features :	OSD Position, OSD Timeout, Factory Reset, Input Source Select
Dimensions :	107mm x 92mm (4.2" x 3.60")
Form Factor :	DV standard & mounting holes.
Power Requirements :	+12VDC $\pm 25\%$, 4w (controller only)
Panel Power :	Supports 3.3V, 5V, 12V panels.
Panel Signal :	TTL & LVDS.
Inverter Support :	DPMS, Analog Brightness control via serial port
Plug & Play:	DDC 1,2/b compatible
Status Indicator :	Dual color LED support.
Operating Temperature:	-40°C to $+80^{\circ}\text{C}^{**}$
Storage Temperature:	-40°C to 85°C
Coating:	Silicone resin conformal coating. (MOD) DEF-STAN 59/47 Issue 4 & UL QMJU2 compliant

HE-1400

Harsh Environment LCD Controller Board

Mechanical Drawing

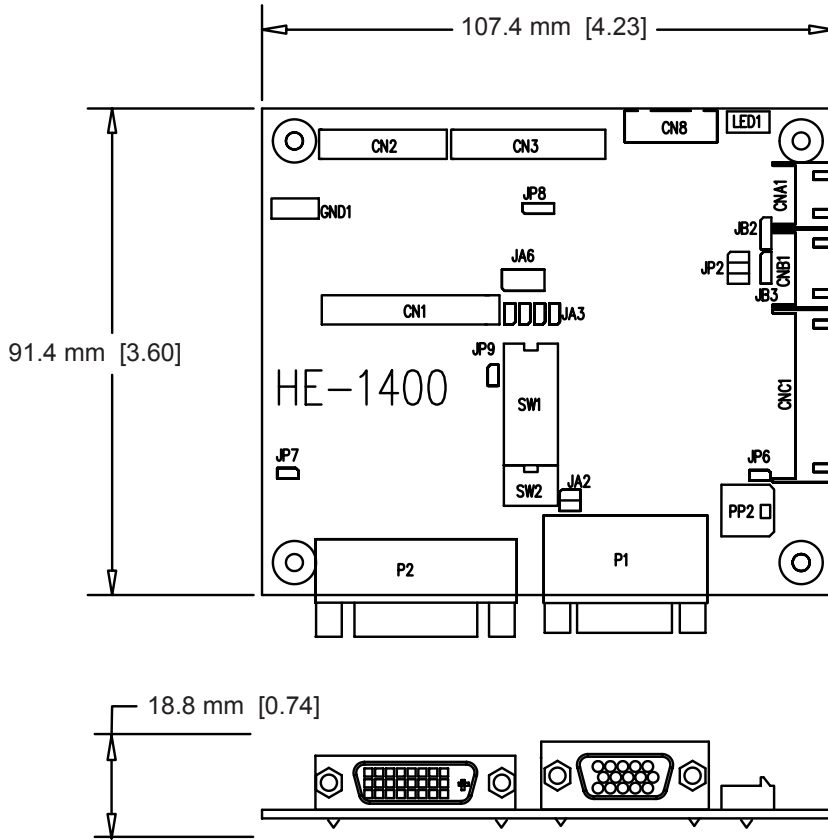

Connector Definitions

CN1	LVDS panel signal
CN2	TTL panel signal
CN7	Audio Board Connector
CN3	TTL Panel Signal
CN8	Serial Control
CNA1	Auxiliary power output
CNB1	Backlight inverter
CNC1	OSD Function controls
LED1	Dual color LED connector for controller status
P1	ARGB signal input
P2	DVI-D signal input
PP2	Main Input Power

Digital View offers a wide range of customization for OEM customers. Services range from unique part number and configuration control, custom layouts and features.

Digital View offers managed product lifecycles with extended product lifetime options and EOL planning. US manufacturing is available on all Digital View products.

Ordering Options

HE-1400 Controller Board	P/N 4171001xx-3
OSD Digital Button Board	Kit 60110-3
OSD Vertical Membrane	Kit 60121-3
OSD Horizontal Membrane	Kit 60125-3
Inverter Interface Board	P/N 416040010-3

3D Drawings (SLDPRT)

Save time and effort for your system volumetric analysis design. Includes jpg file previews.

Please download at www.digitalview.com/products/he-1400-lcd-controller.

Available Resources

- > Instruction Manual
- > Revision Control Documentation**
- > Firmware Upgrade Manual**
- > Mechanical Drawing
- > MTBF Analysis**
- > Certified Laboratory test results
- ** Available on Request

Controller Solution Generator
<http://www.digitalview.com/csg>

EUROPE

6 Marylebone Passage, London, W1W 8EX, UK
 t : +44 (0) 20-7631-2150

ASIA

16th Floor Millennium City 3, 370 Kwun Tong Road, Kwun Tong, Hong Kong
 t : (852) 2861-3615

USA

18440 Technology Drive, Morgan Hill, CA 95037, USA
 t : +1 (408) 782-7773