



Chipsmall Limited consists of a professional team with an average of over 10 year of expertise in the distribution of electronic components. Based in Hongkong, we have already established firm and mutual-benefit business relationships with customers from,Europe,America and south Asia,supplying obsolete and hard-to-find components to meet their specific needs.

With the principle of “Quality Parts,Customers Priority,Honest Operation,and Considerate Service”,our business mainly focus on the distribution of electronic components. Line cards we deal with include Microchip,ALPS,ROHM,Xilinx,Pulse,ON,Everlight and Freescale. Main products comprise IC,Modules,Potentiometer,IC Socket,Relay,Connector.Our parts cover such applications as commercial,industrial, and automotives areas.

We are looking forward to setting up business relationship with you and hope to provide you with the best service and solution. Let us make a better world for our industry!



Contact us

Tel: +86-755-8981 8866 Fax: +86-755-8427 6832

Email & Skype: info@chipsmall.com Web: www.chipsmall.com

Address: A1208, Overseas Decoration Building, #122 Zhenhua RD., Futian, Shenzhen, China



THIS DRAWING IS UNPUBLISHED. RELEASED FOR PUBLICATION
 © COPYRIGHT - By - ALL RIGHTS RESERVED.

LOC	DIST	REVISIONS					
AF	50	P	LTR	DESCRIPTION	DATE	DWN	APVD
		B1		REVISED PER ECR-11-006644	05APR11	HMR	GJ

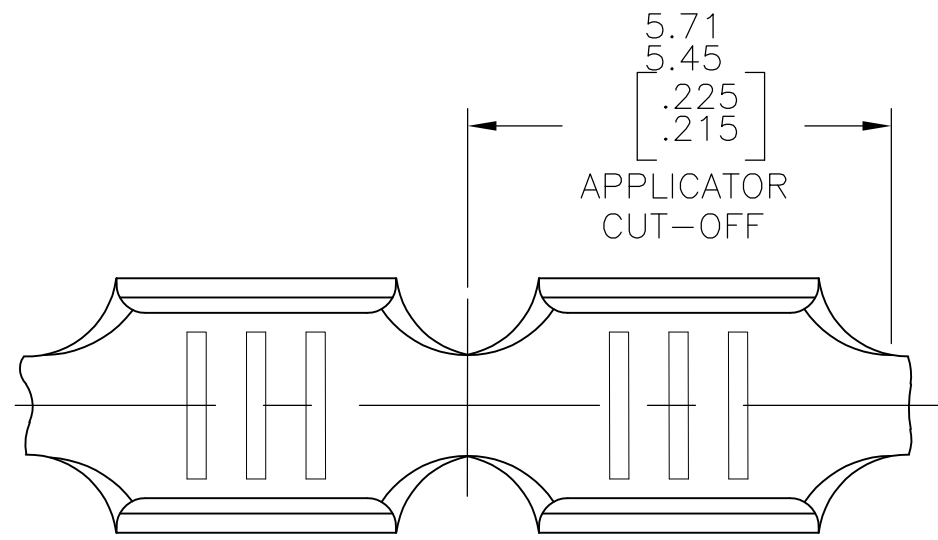

- 1 PRODUCT PROVIDED IN STRIP FORM ON REELS; BREAKS MAY BE PRESENT
- 2 WIRE RANGE: 0.51-1.62 mm²[1000-3200 CMA]
- 3 CRIMP WIDTH: 2.79[.110]F TYPE.
CRIMP HEIGHT IN INCHES (+/- .002)=(TOTAL CMA OF WIRES + 9267)/ 183333.

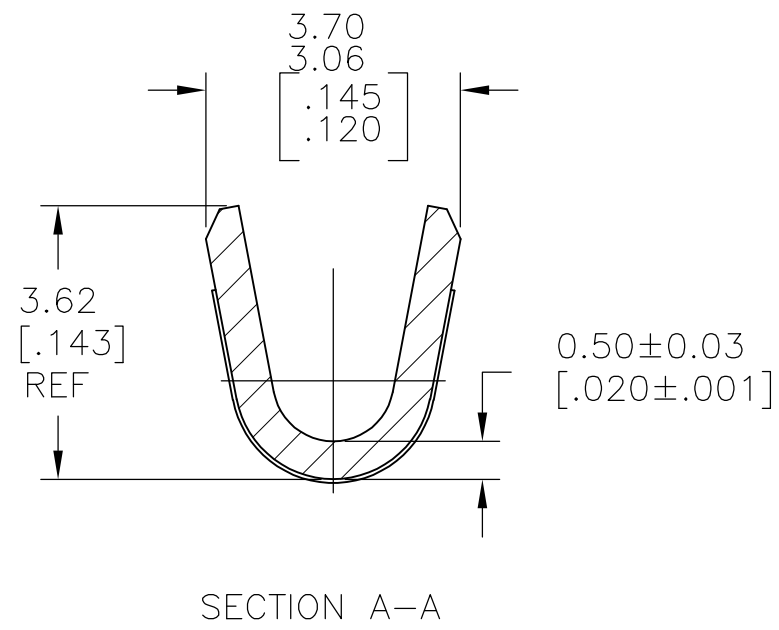
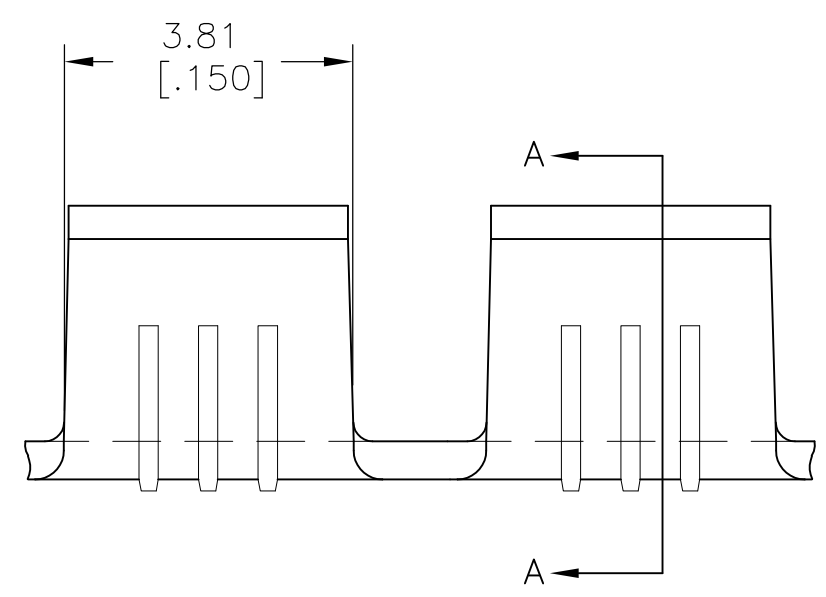

41975
PART NO

THIS DRAWING IS A CONTROLLED DOCUMENT.		DWN RAGHAVENDRA 02JUL07	TE Connectivity				
DIMENSIONS: mm [INCHES]		CHK G.D.PORTA 02JUL07					
TOLERANCES UNLESS OTHERWISE SPECIFIED:		APVD G.D.PORTA 02JUL07	NAME				
0 PLC ± - 1 PLC ± - 2 PLC ± 0.25[.010] 3 PLC ± - 4 PLC ± - ANGLES ± -		PRODUCT SPEC -	SPLICE				
MATERIAL BRASS		FINISH TIN	APPLICATION SPEC 114-2088	SIZE A3	CAGE CODE 00779	DRAWING NO C-41975	RESTRICTED TO -
CUSTOMER DRAWING			WEIGHT -	SCALE 10:1	SHEET 1 OF 1	REV B1	