



Chipsmall Limited consists of a professional team with an average of over 10 year of expertise in the distribution of electronic components. Based in Hongkong, we have already established firm and mutual-benefit business relationships with customers from,Europe,America and south Asia,supplying obsolete and hard-to-find components to meet their specific needs.

With the principle of "Quality Parts,Customers Priority,Honest Operation,and Considerate Service",our business mainly focus on the distribution of electronic components. Line cards we deal with include Microchip,ALPS,ROHM,Xilinx,Pulse,ON,Everlight and Freescale. Main products comprise IC,Modules,Potentiometer,IC Socket,Relay,Connector.Our parts cover such applications as commercial,industrial, and automotives areas.

We are looking forward to setting up business relationship with you and hope to provide you with the best service and solution. Let us make a better world for our industry!



Contact us

Tel: +86-755-8981 8866 Fax: +86-755-8427 6832

Email & Skype: info@chipsmall.com Web: www.chipsmall.com

Address: A1208, Overseas Decoration Building, #122 Zhenhua RD., Futian, Shenzhen, China



MARKETING SALES DRAWING
 DIMENSIONS IN INCHES - DO NOT SCALE THIS DRAWING
 DIMENSIONS IN METRIC - []

Electrical Testing
 per Tusonix standard
 test plans and Mil-Std-202
 Test Methods.

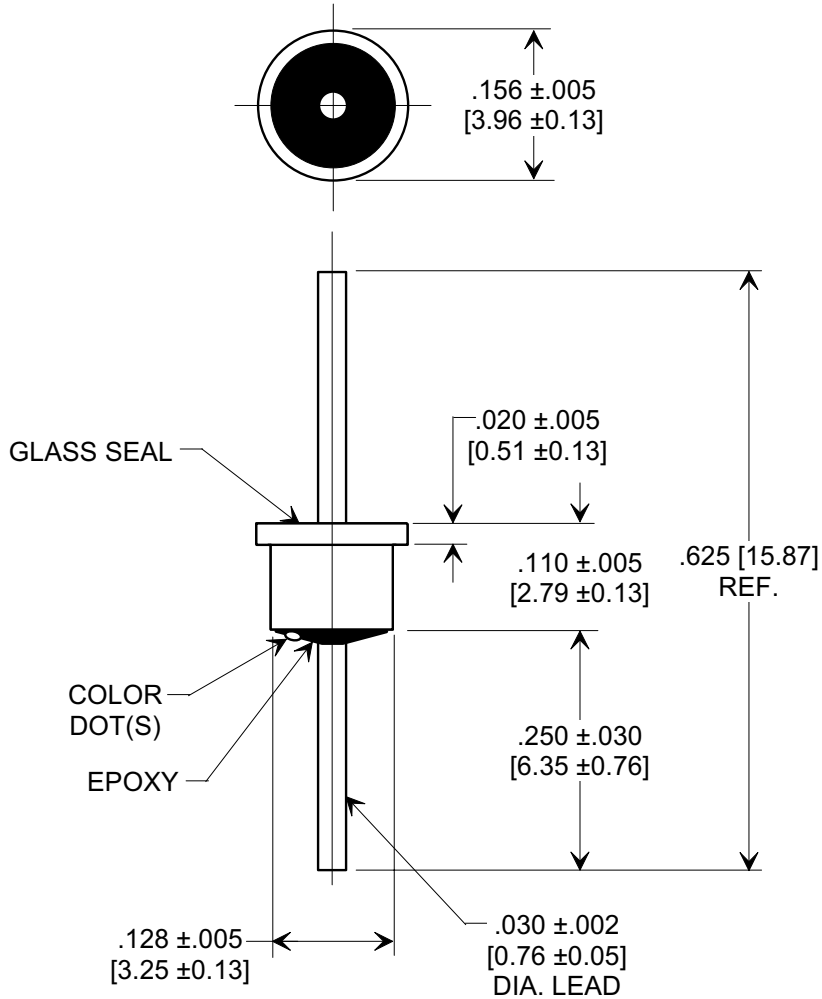
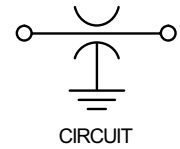
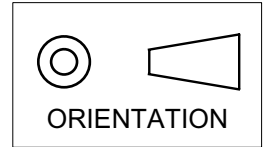

NOTES:

1. Operating temperature range: -55°C to +125°C.
2. Gold plated case and lead.
3. Epoxy sealed on opposite end from glass seal.
4. Max. recommended soldering temperature: 260°C.
See installation recommendations.
5. Recommended mounting hole: .135 [3.43] dia.
6. Solder preform available for mounting.
7. Tusonix Standard part number: 4300-034.
Tusonix RoHS compliant part number: 4300-034 LF.
Customer must specify Standard or RoHS part number when ordering.
8. RoHS compliant part marked with additional dark green dot for identification.

Cx (pF)	TOL.	DC WORKING VOLTAGE		DC CURRENT (AMPS)	DWV (VDC)	I.R. MIN. @ 100 (VDC.)	MIN. NO LOAD INSERTION LOSS (dB) @ 25° C PER MIL-STD-220					COLOR CODE
		85°C	125°C				1 MHz	10 MHz	100 MHz	1GHz	10 GHz	
50,000	GMV	50	50	5	100	10 G	15	35	45	70	---	BLUE--BLUE

X-2015 Rev-0
REVISION RECORD
 Original Release
 C.O. 20020604-1-01
 ADDED NOTES 7 & 8.
 S.M. 05-23-05
 20050511-2-32

--TOLERANCES-- Unless Otherwise Specified	Title	
	SOLDER MOUNT EMI FILTER	
DECIMAL ± NOTED ANGLES ±	Drawn L.E. 06-04-02	Scale 5 X
TUSONIX TUCSON, ARIZONA	Approved B.Mc. 06-04-02	
	A	4300-034