



Chipsmall Limited consists of a professional team with an average of over 10 year of expertise in the distribution of electronic components. Based in Hongkong, we have already established firm and mutual-benefit business relationships with customers from,Europe,America and south Asia,supplying obsolete and hard-to-find components to meet their specific needs.

With the principle of “Quality Parts,Customers Priority,Honest Operation,and Considerate Service”,our business mainly focus on the distribution of electronic components. Line cards we deal with include Microchip,ALPS,ROHM,Xilinx,Pulse,ON,Everlight and Freescale. Main products comprise IC,Modules,Potentiometer,IC Socket,Relay,Connector.Our parts cover such applications as commercial,industrial, and automotives areas.

We are looking forward to setting up business relationship with you and hope to provide you with the best service and solution. Let us make a better world for our industry!



## Contact us

Tel: +86-755-8981 8866 Fax: +86-755-8427 6832

Email & Skype: info@chipsmall.com Web: www.chipsmall.com

Address: A1208, Overseas Decoration Building, #122 Zhenhua RD., Futian, Shenzhen, China



# OptoTEC™ Series OT15-30-F2A-0610

## Thermoelectric Module



Americas: +1.919.597.7300  
Europe: +46.31.420530  
Asia: +86.755.2714.1166  
ets.sales@lairdtech.com  
[www.lairdtech.com](http://www.lairdtech.com)

The OptoTEC™ Series is a miniature thermoelectric module (TEM). This product series is primarily used in applications to stabilize the temperature of sensitive optical components in telecom and photonics industries.

This product line is available in multiple configurations and surface finishing options. Assembled with Bismuth Telluride semiconductor material and thermally conductive Aluminum Oxide ceramics, the OptoTEC Series is designed for lower current and lower heat-pumping applications. Custom designs are available to accommodate metallization, pretinning, ceramic patterns, and solder posts, however MOQ applies.

### FEATURES

- Miniature geometric sizes
- Precise temperature control
- Reliable solid state operation
- No sound or vibration
- DC operation
- RoHS compliant

### APPLICATIONS

- Laser diodes
- CCD cameras
- Infrared (IR) sensors
- Pump lasers
- Crystal oscillators
- Optical transceivers

### SPECIFICATIONS

PERFORMANCE		
Hot Side Temperature (°C)	25	50
Qmax (Watts)	3.0	3.4
Delta Tmax (°C)	67	77
I <sub>max</sub> (Amps)	1.5	1.5
V <sub>max</sub> (Volts)	3.4	3.9
Module resistance (ohms)	2.09	2.35

SUFFIX	THICKNESS PRIOR TO TINNING	FLATNESS & PARALLELISM	HOT FACE	COLD FACE	LEAD LENGTH
11	0.077" ± 0.002"	0.0002" / 0.002"	Lapped	Lapped	2.0"
TB	0.077" ± 0.0005"	0.0005" / 0.0005"	Lapped	Lapped	2.0"
00	0.087" ± 0.005"	NA / NA	Metallized	Metallized	2.0"
22	0.087" ± 0.005"	NA / NA	Pre-tinned	Pre-tinned	2.0"
GG	0.087" ± 0.005"	NA / NA	AuPlated	AuPlated	2.0"

### SEALING OPTIONS

SUFFIX	SEALANT	COLOR	TEMP RANGE	DESCRIPTION
RT	RTV	White	-60 to 204 °C	Non-corrosive, silicone adhesive sealant
EP	Epoxy	Black	-55 to 150 °C	Low density syntactic foam epoxy encapsulant

### PERFORMANCE CURVES

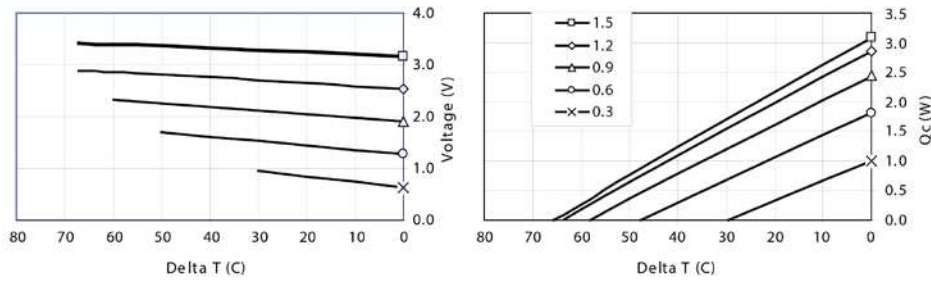

### MECHANICAL DRAWING

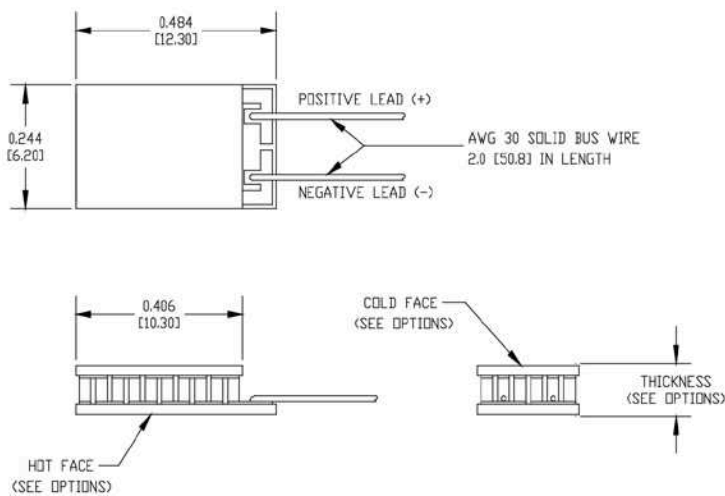

Ceramic Material: 96% Alumina Ceramics  
 Solder Construction: 138°C BiSn

### OPERATING TIPS

- Max operating temperature: 80°C
- Do not exceed I<sub>max</sub> or V<sub>max</sub> when operating module
- Reference assembly guidelines for recommended installation
- Solder tinning also available on metallized ceramics

LAIRD-ETS-OT15-30-F2A-0610-DATA-SHEET-101416

Any information furnished by Laird Technologies, Inc. and its agents is believed to be accurate and reliable. All specifications are subject to change without notice. Responsibility for the use and application of Laird Technologies materials rests with the end user. Laird Technologies makes no warranties as to the fitness, merchantability, suitability or non-infringement of any Laird Technologies materials or products for any specific or general uses. Laird Technologies shall not be liable for incidental or consequential damages of any kind. All Laird Technologies products are sold pursuant to the Laird Technologies' Terms and Conditions of sale in effect from time to time, a copy of which will be furnished upon request. © Copyright 2016 Laird Technologies, Inc. All Rights Reserved. Laird, Laird Technologies, the Laird Technologies Logo, and other marks are trademarks or registered trademarks of Laird Technologies, Inc. or an affiliate company thereof. Other product or service names may be the property of third parties. Nothing herein provides a license under any Laird Technologies or any third party intellectual property rights.