



Chipsmall Limited consists of a professional team with an average of over 10 year of expertise in the distribution of electronic components. Based in Hongkong, we have already established firm and mutual-benefit business relationships with customers from,Europe,America and south Asia,supplying obsolete and hard-to-find components to meet their specific needs.

With the principle of "Quality Parts,Customers Priority,Honest Operation,and Considerate Service",our business mainly focus on the distribution of electronic components. Line cards we deal with include Microchip,ALPS,ROHM,Xilinx,Pulse,ON,Everlight and Freescale. Main products comprise IC,Modules,Potentiometer,IC Socket,Relay,Connector.Our parts cover such applications as commercial,industrial, and automotives areas.

We are looking forward to setting up business relationship with you and hope to provide you with the best service and solution. Let us make a better world for our industry!



## Contact us

Tel: +86-755-8981 8866 Fax: +86-755-8427 6832

Email & Skype: info@chipsmall.com Web: www.chipsmall.com

Address: A1208, Overseas Decoration Building, #122 Zhenhua RD., Futian, Shenzhen, China



**METRAL 5 ROW STANDARD, 1000, 2000, & 4000 SERIES, & EE HEADER / SHROUD INSERTION TOOLING**

**FEATURES:**

- Inserts Metral 5 Row Standard, 1000, 2000, & 4000 Series, & EE headers onto a PCB.
- Inserts Metral 5 Row 1000 Series & 2000 Series shrouds onto the headers installed on the PCB.\*\*  
 \*\*Metral standard 5 row shroud can be installed w/ 166624-xxx shroud press block. See the Info sheet for Metral 4 & 5 Row Standard Shroud Insertion Tooling.
- End-to-End stackable.
- Use manually or in an automatic insertion machine.
- Polarization keys insure proper tooling-to-connector alignment.
- End web design allows tooling to fit within length of connector & prevents end wall damage.
- Press block can be used as bottom PCB support.

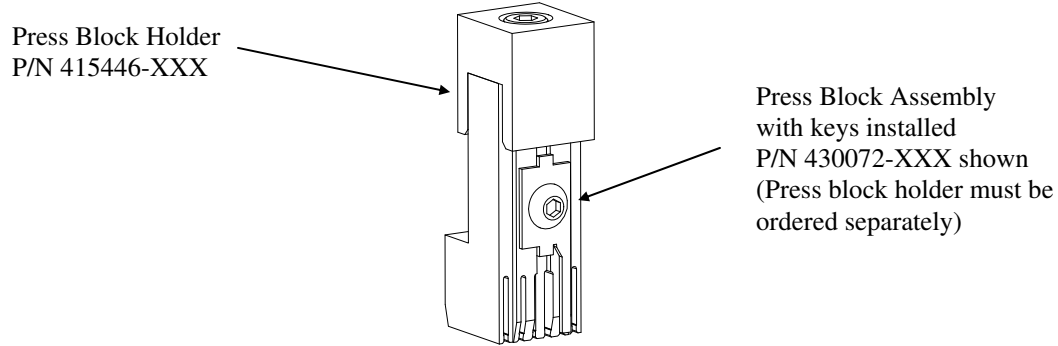

**5 ROW WIDE BODY PRESS BLOCK ASS'Y P/N:**

**TOOLING P/N**

**PRODUCT DESCRIPTION**

<b><u>430072-001</u></b>	1 module Metral 5 row Standard 1000, 2000, & 4000 series & EE header/shroud press block
<b><u>430072-002</u></b>	2 module Metral 5 row Standard 1000, 2000, & 4000 series & EE header/shroud press block
<b><u>430072-003</u></b>	4 module Metral 5 row Standard 1000, 2000, & 4000 series & EE header/shroud press block
<b><u>430072-004</u></b>	8 module Metral 5 row Standard 1000, 2000, & 4000 series & EE header/shroud press block

**5 ROW WIDE BODY EXTENDED PRESS BLOCK ASS'Y P/N:**

**TOOLING P/N**

**PRODUCT DESCRIPTION**

<b><u>430075-001</u></b>	1 Module Metral 5 Row 1000 & 2000 Series Wide Body header/shroud press block
<b><u>430075-002</u></b>	2 Module Metral 5 Row 1000 & 2000 Series Wide Body header/shroud press block
<b><u>430075-003</u></b>	4 Module Metral 5 Row 1000 & 2000 Series Wide Body header/shroud press block
<b><u>430075-004</u></b>	8 Module Metral 5 Row 1000 & 2000 Series Wide Body header/shroud press block

**4 & 5 ROW PRESS BLOCK HOLDER P/N:**

<b><u>415446-001</u></b>	1 – 12 mm module	<b><u>415446-013</u></b>	12 – 12 mm modules
<b><u>415446-002</u></b>	2 – 12 mm modules	<b><u>415446-014</u></b>	13 – 12 mm modules
<b><u>415446-003</u></b>	4 – 12 mm modules	<b><u>415446-015</u></b>	14 – 12 mm modules
<b><u>415446-004</u></b>	8 – 12 mm modules	<b><u>415446-016</u></b>	15 – 12 mm modules
<b><u>415446-005</u></b>	21 – 12 mm modules	<b><u>415446-017</u></b>	16 – 12 mm modules
<b><u>415446-006</u></b>	3 – 12 mm modules	<b><u>415446-018</u></b>	17 – 12 mm modules
<b><u>415446-007</u></b>	5 – 12 mm modules	<b><u>415446-019</u></b>	18 – 12 mm modules
<b><u>415446-008</u></b>	6 – 12 mm modules	<b><u>415446-020</u></b>	19 – 12 mm modules
<b><u>415446-009</u></b>	7 – 12 mm modules	<b><u>415446-021</u></b>	20 – 12 mm modules
<b><u>415446-010</u></b>	9 – 12 mm modules	<b><u>415446-101</u></b>	21 – 12 mm modules
<b><u>415446-011</u></b>	10 – 12 mm modules		
<b><u>415446-012</u></b>	11 – 12 mm modules		

**5 ROW BOARD SUPPORT: (for use with 5 Row Metral Headers Only – not to be used with shrouds)**

<b><u>415609-001</u></b>	1- 12 mm module	<b><u>415609-003</u></b>	1- 48 mm module
<b><u>415609-002</u></b>	1- 24 mm module	<b><u>415609-004</u></b>	1- 96 mm module

## **PRESSES TO INSERT METRAL 5 ROW STANDARD, 1000, 2000, & 4000 SERIES VERTICAL HEADERS & SHROUDS**

Metral vertical press-fit headers and shrouds can be installed with any standard press as long as it has enough force to properly install the number of pins that are being inserted.

FCI also offers a manual press that can be used to insert up to 4 modules at a time. Insertion tooling must be purchased separately. Bottom tooling is not supplied since most customers prefer to design their own support fixtures, or use a PCB with oversized holes.

### **MT-301 HAND PRESS P/N 194205-002**

- Inserts up to 4 modules at a time.
- Height of ram is adjustable from 1.5” to 6.5”
- Throat depth is 4.5” to center of ram
- Press capacity is 1 ton

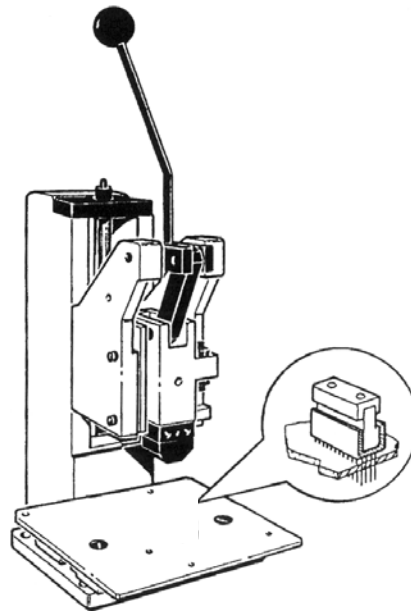

### **Impress Press**

FCI manufactures a complete line of servo-driven electric presses to install all press fit connectors. The Impress line of presses range from a manual placement, operator actuated press to a fully automated pick, place, and press unit. The entire line up of machine features includes state of the art electronic press controls with a closed loop feedback system. Contact your local sales representative for additional information on the Impress line of presses or visit our website at [www.FCICONNECT.COM](http://www.FCICONNECT.COM).