



Chipsmall Limited consists of a professional team with an average of over 10 year of expertise in the distribution of electronic components. Based in Hongkong, we have already established firm and mutual-benefit business relationships with customers from,Europe,America and south Asia,supplying obsolete and hard-to-find components to meet their specific needs.

With the principle of “Quality Parts,Customers Priority,Honest Operation,and Considerate Service”,our business mainly focus on the distribution of electronic components. Line cards we deal with include Microchip,ALPS,ROHM,Xilinx,Pulse,ON,Everlight and Freescale. Main products comprise IC,Modules,Potentiometer,IC Socket,Relay,Connector.Our parts cover such applications as commercial,industrial, and automotives areas.

We are looking forward to setting up business relationship with you and hope to provide you with the best service and solution. Let us make a better world for our industry!



## Contact us

Tel: +86-755-8981 8866 Fax: +86-755-8427 6832

Email & Skype: info@chipsmall.com Web: www.chipsmall.com

Address: A1208, Overseas Decoration Building, #122 Zhenhua RD., Futian, Shenzhen, China





# 4302F-5V, 4302F-12V Series Integrated Resistor 5 Volts 12 Volts T-1 (3mm)



Through-hole LEDs with Built-in 5V and 12V Resistor in the standard T-1 (3mm) size LED package. Available in 3 colors and 60° viewing angle

## Key Features

- Integral current limiting resistor
- Wide viewing angle: 60°.
- TTL compatible requires no external current limiter with 5V or 12V supply.

## Electro-Optical Characteristics and Ratings

PART NUMBER	4302F1-5V	4302F3-5V	4302F5-5V	4302F1-12V	4302F3-12V	4302F5-12V
Output Color	Red	Amber	Green	Red	Amber	Green
Diffusion	Diffused	Diffused	Diffused	Diffused	Diffused	Diffused
Package Color	Red	Amber	Green	Red	Amber	Green
Rated Current (mA)	10	10	10	13	13	13
Forward Voltage Typ. (V)	5	5	5	12	12	12
Forward Voltage Max. (V)	7.5	7.5	7.5	15	15	15
Luminous Intensity Min. (mcd)	2.0	2.0	2.0	2.1	2.0	2.0
Luminous Intensity Typ. (mcd)	8.0	8.0	8.0	8.0	8.0	8.0
Continuous Forward Current Max. (mA)	20	15	15	20	20	20
Peak Wavelength (nm)	635	583	565	635	583	565
Viewing Angle 2θ 1/2 (degrees)	60	60	60	60	60	60
Reverse Breakdown Voltage Min. (V)	5	5	5	5	5	5
Operating Temperature (°C)	-40 to +80	-40 to +85	-40 to +85	-40 to +85	-40 to +85	-20 to +85
Storage Temperature (°C)	-55 to +100	-55 to +100	-55 to +100	-55 to +100	-55 to +100	-55 to +100
Lead Solder Time at 260°C (sec.)	5	5	5	5	5	5

# Product Dimensions

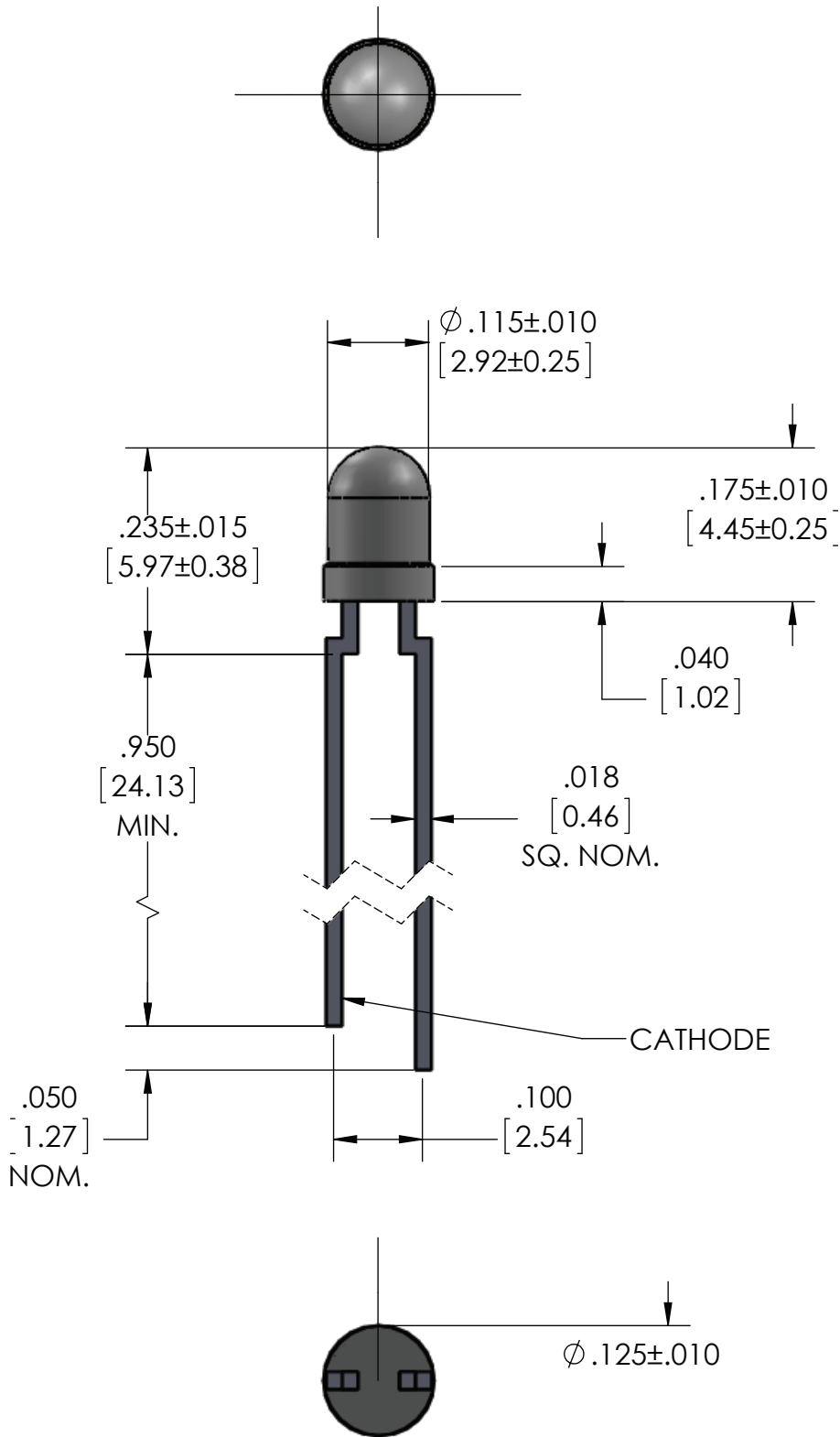

Dimensions in inches [mm]