



Chipsmall Limited consists of a professional team with an average of over 10 year of expertise in the distribution of electronic components. Based in Hongkong, we have already established firm and mutual-benefit business relationships with customers from,Europe,America and south Asia,supplying obsolete and hard-to-find components to meet their specific needs.

With the principle of “Quality Parts,Customers Priority,Honest Operation,and Considerate Service”,our business mainly focus on the distribution of electronic components. Line cards we deal with include Microchip,ALPS,ROHM,Xilinx,Pulse,ON,Everlight and Freescale. Main products comprise IC,Modules,Potentiometer,IC Socket,Relay,Connector.Our parts cover such applications as commercial,industrial, and automotives areas.

We are looking forward to setting up business relationship with you and hope to provide you with the best service and solution. Let us make a better world for our industry!



## Contact us

Tel: +86-755-8981 8866 Fax: +86-755-8427 6832

Email & Skype: info@chipsmall.com Web: www.chipsmall.com

Address: A1208, Overseas Decoration Building, #122 Zhenhua RD., Futian, Shenzhen, China



## Product Description

The PE4304 is a 75-ohm high-linearity, 6-bit RF Digital Step Attenuator (DSA) covering a 31.5 dB attenuation range in 0.5 dB steps. The PE4304 provides both a parallel (latched or direct mode) and serial CMOS control interface, operates on a single 3-volt supply and maintains high attenuation accuracy over frequency and temperature. It also has a unique control interface that allows the user to select an initial attenuation state at power-up. The PE4304 exhibits very low insertion loss and low power consumption. This functionality is delivered in a 4x4 mm QFN footprint.

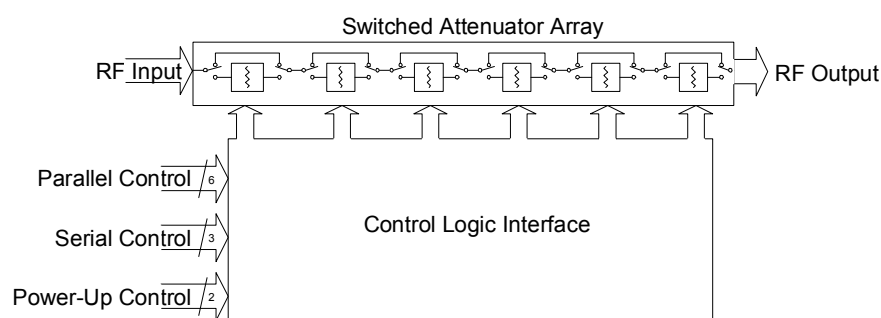
The PE4304 is manufactured on Peregrine's UltraCMOS™ process, a patented variation of silicon-on-insulator (SOI) technology on a sapphire substrate, offering the performance of GaAs with the economy and integration of conventional CMOS.

**75 Ω RF Digital Attenuator**  
**6-bit, 31.5 dB, DC – 2.0 GHz**

### Features

- 75 Ω impedance
- Attenuation: 0.5 dB steps to 31.5 dB
- Low distortion for CATV and multi-carrier applications
- Flexible parallel and serial programming interfaces
- Unique power-up state selection
- Positive CMOS control logic
- High attenuation accuracy and linearity over temperature and frequency
- Very low power consumption
- Single-supply operation
- Packaged in a 20 lead 4x4 mm QFN

**Figure 1. Functional Schematic Diagram**



**Figure 2. Package Type**

4x4 mm 20-Lead QFN



**Table 1. Electrical Specifications @ +25 °C, V<sub>DD</sub> = 3.0 V, Z<sub>o</sub> = 75 Ω**

| Parameter                              | Test Conditions                      | Frequency       | Minimum | Typical | Maximum                             | Units |
|--|--------------------------------------|-----------------|---------|---------|-------------------------------------|-------|
| Operation Frequency                    |                                      |                 | DC      |         | 2000                                | MHz   |
| Insertion Loss <sup>2</sup>            |                                      | DC ≤ 1.2 GHz    | -       | 1.4     | 1.8                                 | dB    |
| Attenuation Accuracy                   | Any Bit or Bit Combination           | DC ≤ 1.2 GHz    | -       | -       | ±(0.15 + 4% of attenuation setting) | dB    |
| 1 dB Compression <sup>3,4</sup>        |                                      | 1 MHz ≤ 1.2 GHz | 30      | 34      | -                                   | dBm   |
| Input IP <sub>3</sub> <sup>1,2,4</sup> | Two-tone inputs up to +18 dBm        | 1 MHz ≤ 1.2 GHz | -       | 52      | -                                   | dBm   |
| Return Loss                            |                                      | DC ≤ 1.2 GHz    | 10      | 13      | -                                   | dB    |
| Switching Speed                        | 50% control to 0.5 dB of final value |                 | -       | -       | 1                                   | μs    |

Notes: 1. Device Linearity will begin to degrade below 1Mhz

2. Max input rating in Table 3 & Figures on Pages 4 to 6 for data across frequency.

3. Note Absolute Maximum in Table 3.

4. Measured in a 50 Ω system.

Figure 3. Pin Configuration (Top View)

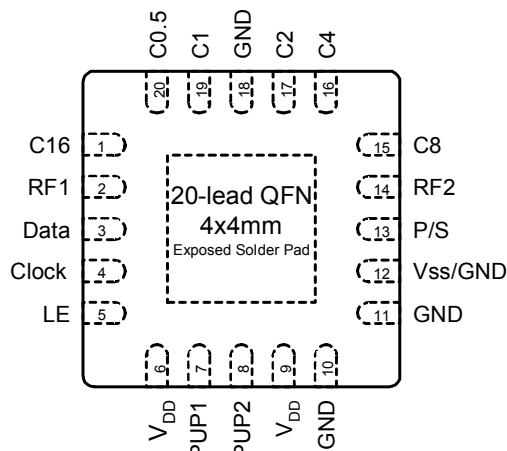


Table 2. Pin Descriptions

| Pin No. | Pin Name             | Description  |
|---------|----------------------|--|
| 1       | C16                  | Attenuation control bit, 16dB (Note 4).            |
| 2       | RF1                  | RF port (Note 1).                                  |
| 3       | Data                 | Serial interface data input (Note 4).              |
| 4       | Clock                | Serial interface clock input.                      |
| 5       | LE                   | Latch Enable input (Note 2).                       |
| 6       | V <sub>DD</sub>      | Power supply pin.                                  |
| 7       | PUP1                 | Power-up selection bit, MSB.                       |
| 8       | PUP2                 | Power-up selection bit, LSB.                       |
| 9       | V <sub>DD</sub>      | Power supply pin.                                  |
| 10      | GND                  | Ground connection.                                 |
| 11      | GND                  | Ground connection.                                 |
| 12      | V <sub>SS</sub> /GND | Negative supply voltage or GND connection (Note 3) |
| 13      | P/S                  | Parallel/Serial mode select.                       |
| 14      | RF2                  | RF port (Note 1).                                  |
| 15      | C8                   | Attenuation control bit, 8 dB.                     |
| 16      | C4                   | Attenuation control bit, 4 dB.                     |
| 17      | C2                   | Attenuation control bit, 2 dB.                     |
| 18      | GND                  | Ground connection.                                 |
| 19      | C1                   | Attenuation control bit, 1 dB.                     |
| 20      | C0.5                 | Attenuation control bit, 0.5 dB.                   |
| Paddle  | GND                  | Ground for proper operation                        |

- Note 1: Both RF ports must be DC blocked with an external series capacitor or held at 0 V<sub>DC</sub>.  
 2: Latch Enable (LE) has an internal 100 kΩ resistor to V<sub>DD</sub>.  
 3: Connect pin 12 to GND to enable internal negative voltage generator. Connect pin 12 to V<sub>SS</sub> (-V<sub>DD</sub>) to bypass and disable internal negative voltage generator.  
 4: Place a 10 kΩ resistor in series, as close to pin as possible.

Table 3. Absolute Maximum Ratings

| Symbol           | Parameter/Conditions           | Min  | Max                  | Units |
|------------------|--------------------------------|------|----------------------|-------|
| V <sub>DD</sub>  | Power supply voltage           | -0.3 | 4.0                  | V     |
| V <sub>I</sub>   | Voltage on any input           | -0.3 | V <sub>DD</sub> +0.3 | V     |
| T <sub>ST</sub>  | Storage temperature range      | -65  | 150                  | °C    |
| P <sub>IN</sub>  | Input power (50Ω)              |      | +30                  | dBm   |
| V <sub>ESD</sub> | ESD voltage (Human Body Model) |      | 500                  | V     |

Table 4. Operating Ranges

| Parameter                            | Min                 | Typ | Max                 | Units |
|--------------------------------------|---------------------|-----|---------------------|-------|
| V <sub>DD</sub> Power Supply Voltage | 2.7                 | 3.0 | 3.3                 | V     |
| I <sub>DD</sub> Power Supply Current |                     |     | 100                 | μA    |
| Digital Input High                   | 0.7xV <sub>DD</sub> |     |                     | V     |
| Digital Input Low                    |                     |     | 0.3xV <sub>DD</sub> | V     |
| Digital Input Leakage                |                     |     | 1                   | μA    |
| Input Power                          |                     |     | +24                 | dBm   |
| Temperature range                    | -40                 |     | 85                  | °C    |

### Exposed Solder Pad Connection

The exposed solder pad on the bottom of the package must be grounded for proper device operation.

### Electrostatic Discharge (ESD) Precautions

When handling this UltraCMOS™ device, observe the same precautions that you would use with other ESD-sensitive devices. Although this device contains circuitry to protect it from damage due to ESD, precautions should be taken to avoid exceeding the rate specified in Table 3.

### Latch-Up Avoidance

Unlike conventional CMOS devices, UltraCMOS™ devices are immune to latch-up.

### Switching Frequency

The PE4304 has a maximum 25 kHz switching rate.

### Resistor on Pin 1 & 3

A 10 kΩ resistor on the inputs to Pin 1 & 3 (see Figure 5) will eliminate package resonance between the RF input pin and the two digital inputs. Specified attenuation error versus frequency performance is dependent upon this condition.

## Evaluation Kit

The Digital Attenuator Evaluation Kit board was designed to ease customer evaluation of the PE4304 Digital Step Attenuator.

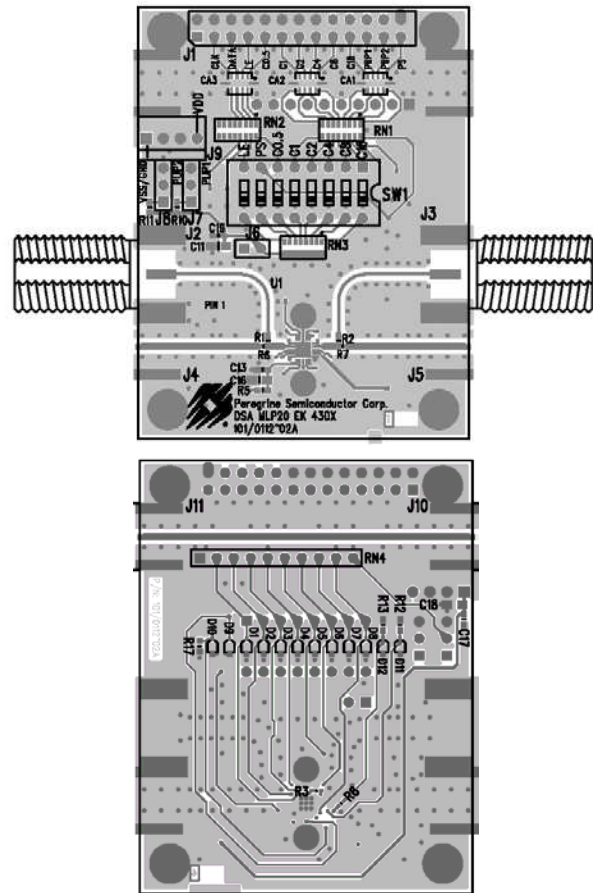
J9 is used in conjunction with the supplied DC cable to supply  $V_{DD}$ , GND, and  $-V_{DD}$ . If use of the internal negative voltage generator is desired, then do not connect  $-V_{DD}$  (Black banana plug). If an external  $-V_{DD}$  is desired, then apply -3V.

J1 should be connected to the parallel port of a PC with the supplied ribbon cable. The evaluation software is written to operate the DSA in serial mode, so Switch 7 (P/S) should be ON with all other switches off. Using the software, enable or disable each attenuation setting to the desired combined attenuation. The software automatically programs the DSA each time an attenuation state is enabled or disabled.

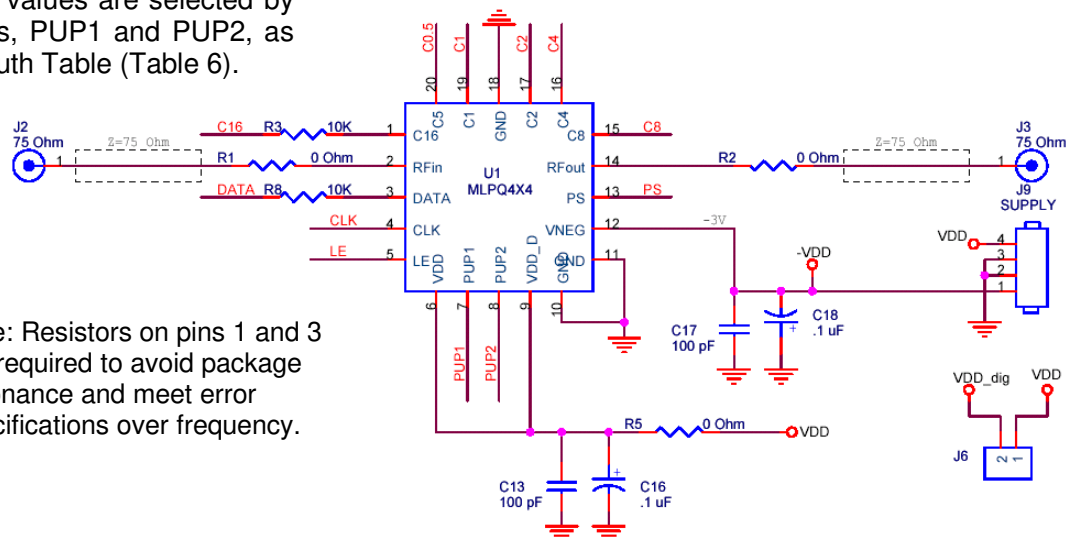
To evaluate the Power up options, first disconnect the parallel ribbon cable from the evaluation board. The parallel cable must be removed to prevent the PC parallel port from biasing the control pins to unknown states. During power up in serial mode (P/S=1 and LE=0) or in parallel mode with P/S=0 and LE=1, the default power-up signal attenuation is set to the value present on the six control bits on the six parallel data inputs (C0.5 to C16). This allows any one of the 64 attenuation settings to be specified as the power-up state.

To power up in Parallel mode (P/S=0) with LE=0, the control bits are automatically set to one of four possible values. These four values are selected by the two power-up control bits, PUP1 and PUP2, as shown in the Parallel PUP Truth Table (Table 6).

**Figure 4. Evaluation Board Layout**  
Peregrine Specification 101/0112



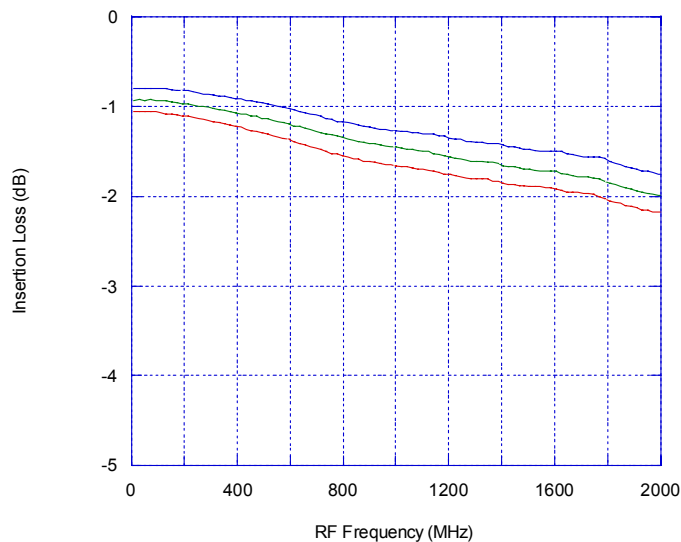
**Figure 5. Evaluation Board Schematic**  
Peregrine Specification 102/0142



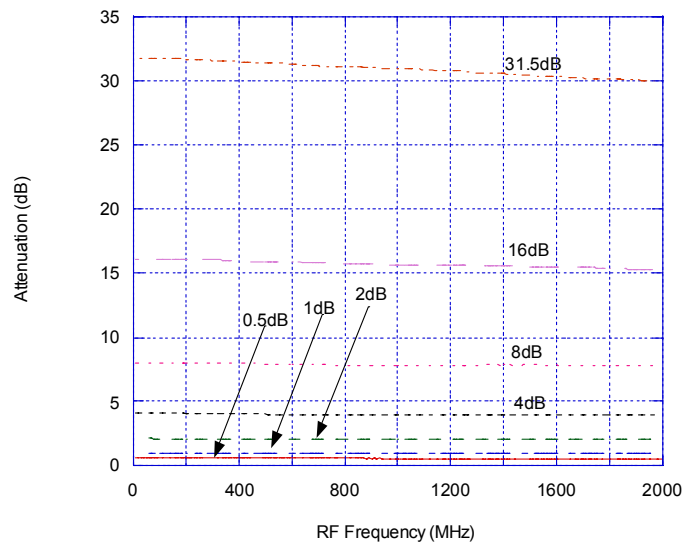
Note: Resistors on pins 1 and 3 are required to avoid package resonance and meet error specifications over frequency.

**Typical Performance Data @ 25°C, V<sub>DD</sub> = 3.0 V (unless otherwise specified)**

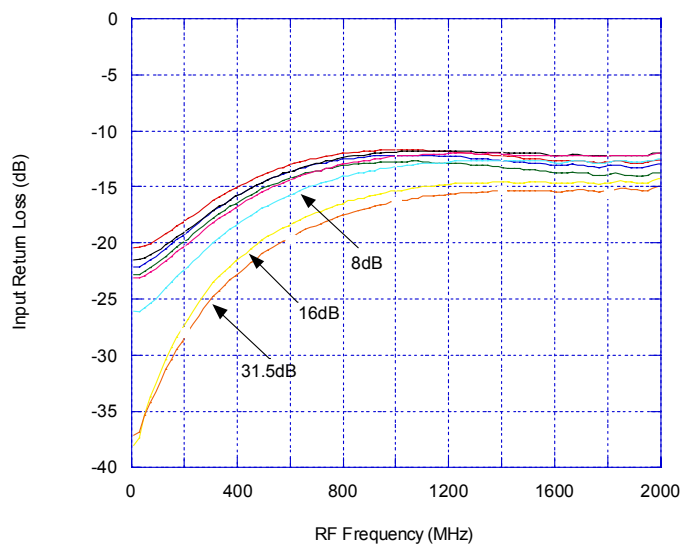
**Figure 6. Insertion Loss**



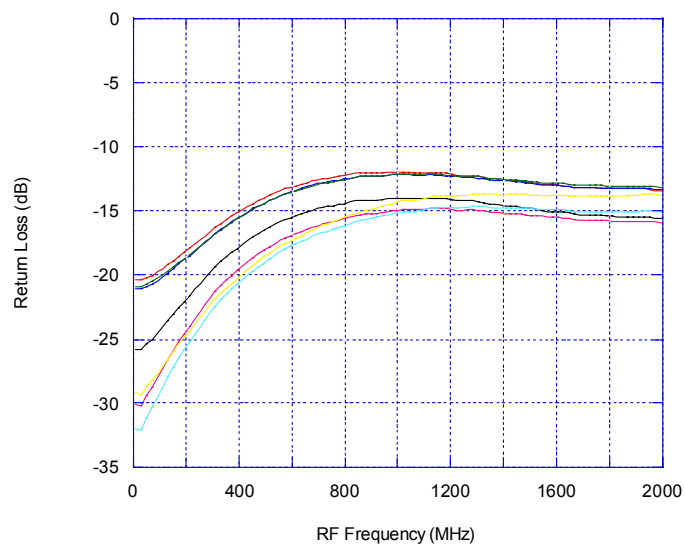
**Figure 7. Attenuation at Major steps**



**Figure 8. Input Return Loss at Major Attenuation Steps**



**Figure 9. Output Return Loss at Major Attenuation Steps**



Typical Performance Data @ 25°C, V<sub>DD</sub> = 3.0 V (unless otherwise specified)

Figure 10. Attenuation Error Vs. Frequency

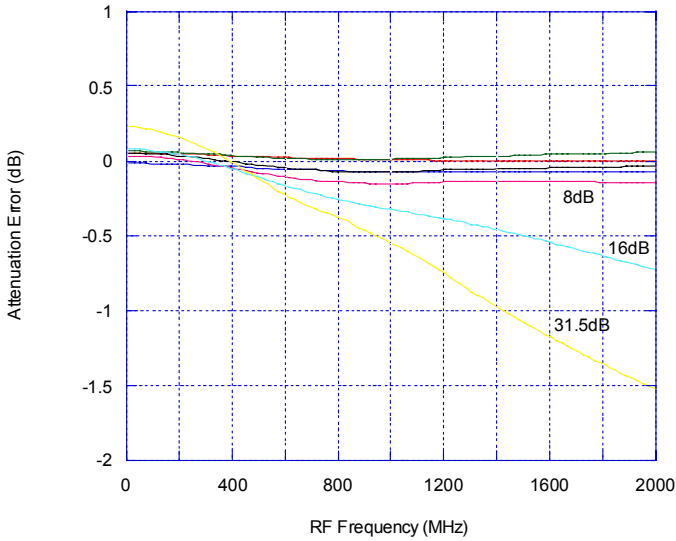


Figure 11. Attenuation Error Vs. Attenuation Setting

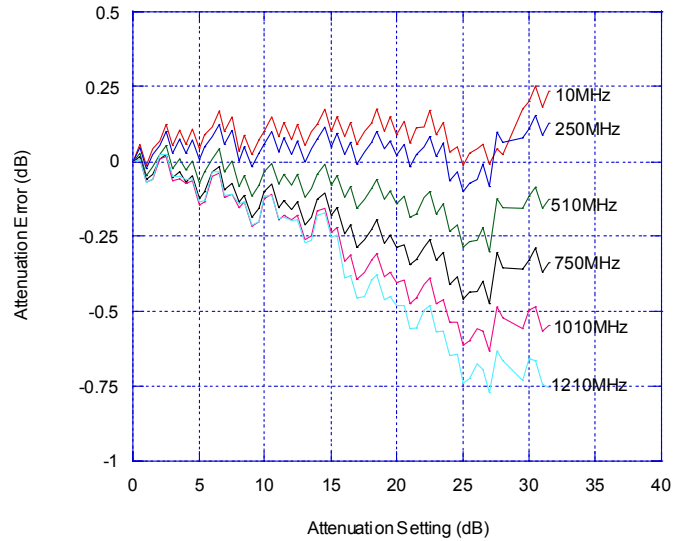


Figure 12. Attenuation Error Vs. Attenuation Setting

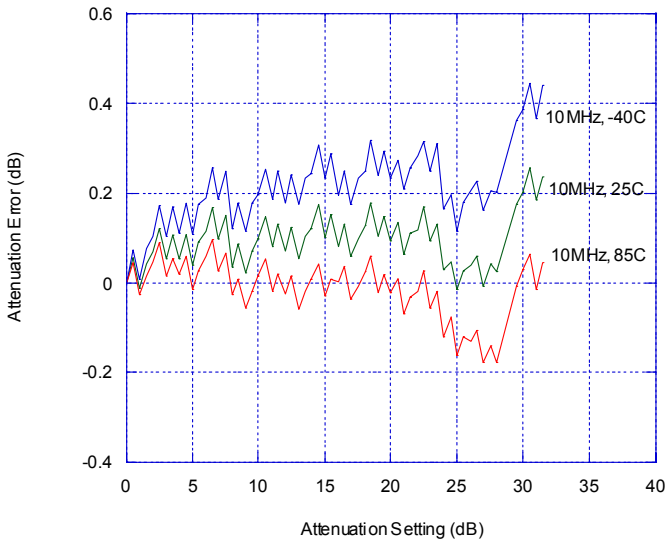
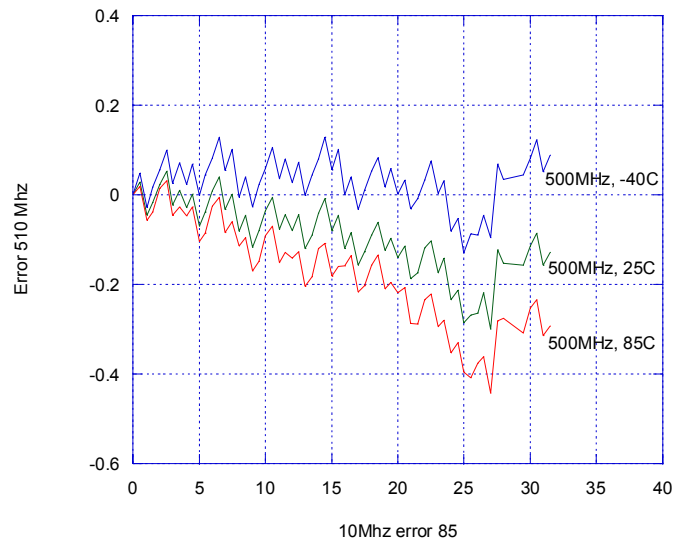


Figure 13. Attenuation Error Vs. Attenuation Setting



Note: Positive attenuation error indicates higher attenuation than target value

Typical Performance Data @ 25°C, V<sub>DD</sub> = 3.0 V (unless otherwise specified)

Figure 14. Attenuation Error Vs. Frequency

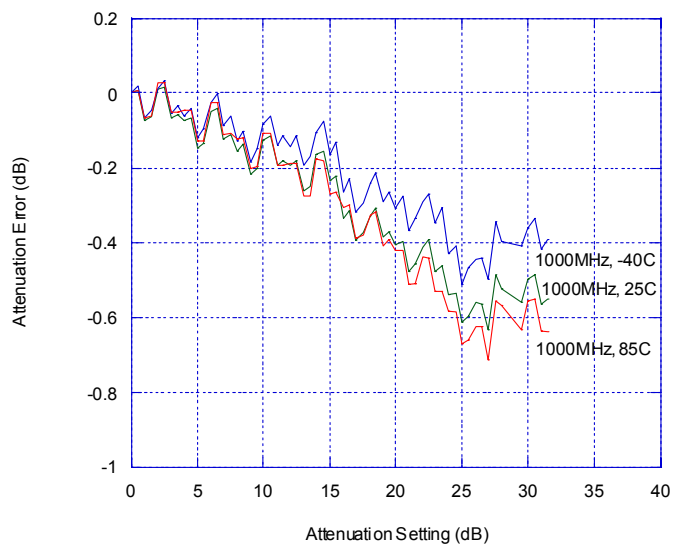


Figure 15. Input IP3 Vs. Frequency

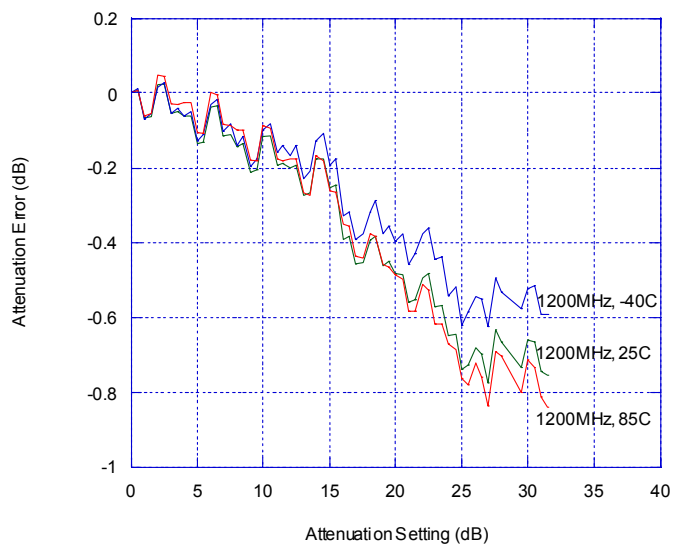


Figure 16. Input 1dB Compression  
(Major attenuation states, 50 Ω System)

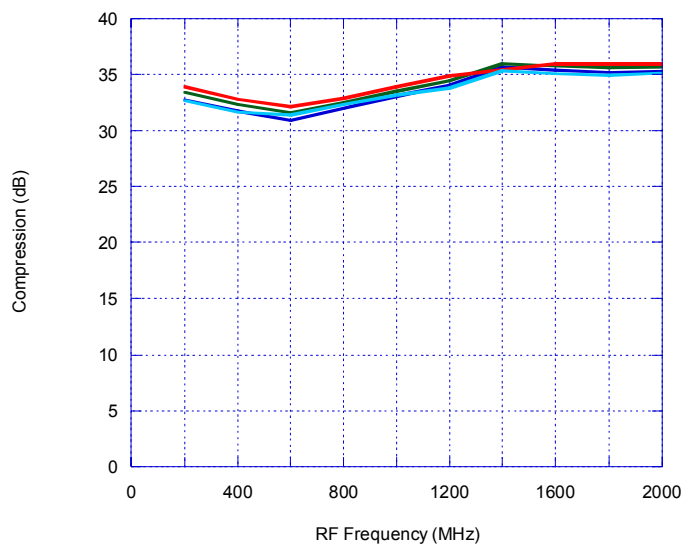
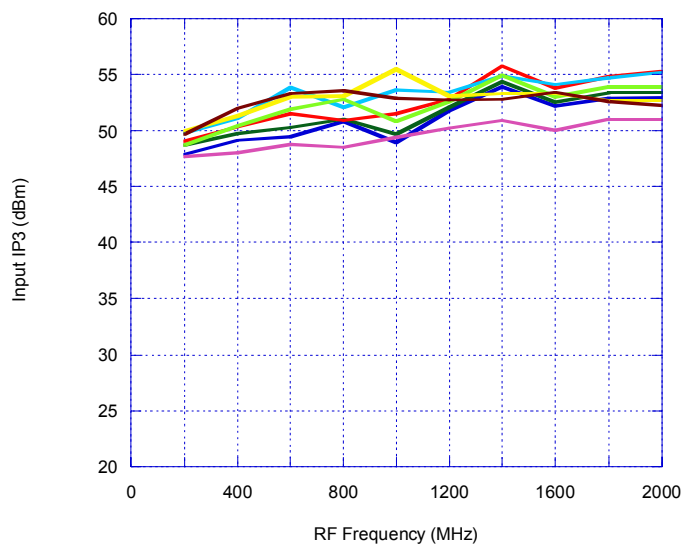


Figure 17. Input IP3 Vs. Frequency  
(Major attenuation states, 50 Ω System)



Note: Positive attenuation error indicates higher attenuation than target value

## Programming Options

### Parallel/Serial Selection

Either a parallel or serial interface can be used to control the PE4304. The P/S bit provides this selection, with P/S=LOW selecting the parallel interface and P/S=HIGH selecting the serial interface.

### Parallel Mode Interface

The parallel interface consists of five CMOS-compatible control lines that select the desired attenuation state, as shown in Table 5.

The parallel interface timing requirements are defined by Figure 19 (Parallel Interface Timing Diagram), Table 9 (Parallel Interface AC Characteristics), and switching speed (Table 1).

For *latched* parallel programming the Latch Enable (LE) should be held LOW while changing attenuation state control values, then pulse LE HIGH to LOW (per Figure 19) to latch new attenuation state into device.

For *direct* parallel programming, the Latch Enable (LE) line should be pulled HIGH. Changing attenuation state control values will change device state to new attenuation. Direct Mode is ideal for manual control of the device (using hardware, switches, or jumpers).

**Table 5. Truth Table**

| P/S | C16 | C8 | C4 | C2 | C1 | C0.5 | Attenuation State |
|-----|-----|----|----|----|----|------|-------------------|
| 0   | 0   | 0  | 0  | 0  | 0  | 0    | Reference Loss    |
| 0   | 0   | 0  | 0  | 0  | 0  | 1    | 0.5 dB            |
| 0   | 0   | 0  | 0  | 0  | 1  | 0    | 1 dB              |
| 0   | 0   | 0  | 0  | 1  | 0  | 0    | 2 dB              |
| 0   | 0   | 0  | 1  | 0  | 0  | 0    | 4 dB              |
| 0   | 0   | 1  | 0  | 0  | 0  | 0    | 8 dB              |
| 0   | 1   | 0  | 0  | 0  | 0  | 0    | 16 dB             |
| 0   | 1   | 1  | 1  | 1  | 1  | 1    | 31.5 dB           |

Note: Not all 64 possible combinations of C0.5-C16 are shown in table

### Serial Interface

The serial interface is a 6-bit serial-in, parallel-out shift register buffered by a transparent latch. It is controlled by three CMOS-compatible signals: Data,

Clock, and Latch Enable (LE). The Data and Clock inputs allow data to be serially entered into the shift register, a process that is independent of the state of the LE input.

The LE input controls the latch. When LE is HIGH, the latch is transparent and the contents of the serial shift register control the attenuator. When LE is brought LOW, data in the shift register is latched.

The shift register should be loaded while LE is held LOW to prevent the attenuator value from changing as data is entered. The LE input should then be toggled HIGH and brought LOW again, latching the new data. The timing for this operation is defined by Figure 18 (Serial Interface Timing Diagram) and Table 8 (AC Characteristics).

### Power-up Control Settings

The PE4304 always assumes a specifiable attenuation setting on power-up. This feature exists for both the Serial and Parallel modes of operation, and allows a known attenuation state to be established before an initial serial or parallel control word is provided.

When the attenuator powers up in Serial mode (P/S=1), the six control bits are set to whatever data is present on the six parallel data inputs (C0.5 to C16). This allows any one of the 64 attenuation settings to be specified as the power-up state.

When the attenuator powers up in Parallel mode (P/S=0) with LE=0, the control bits are automatically set to one of four possible values. These four values are selected by the two power-up control bits, PUP1 and PUP2, as shown in Table 6 (Power-Up Truth Table, Parallel Mode).

**Table 6. Parallel PUP Truth Table**

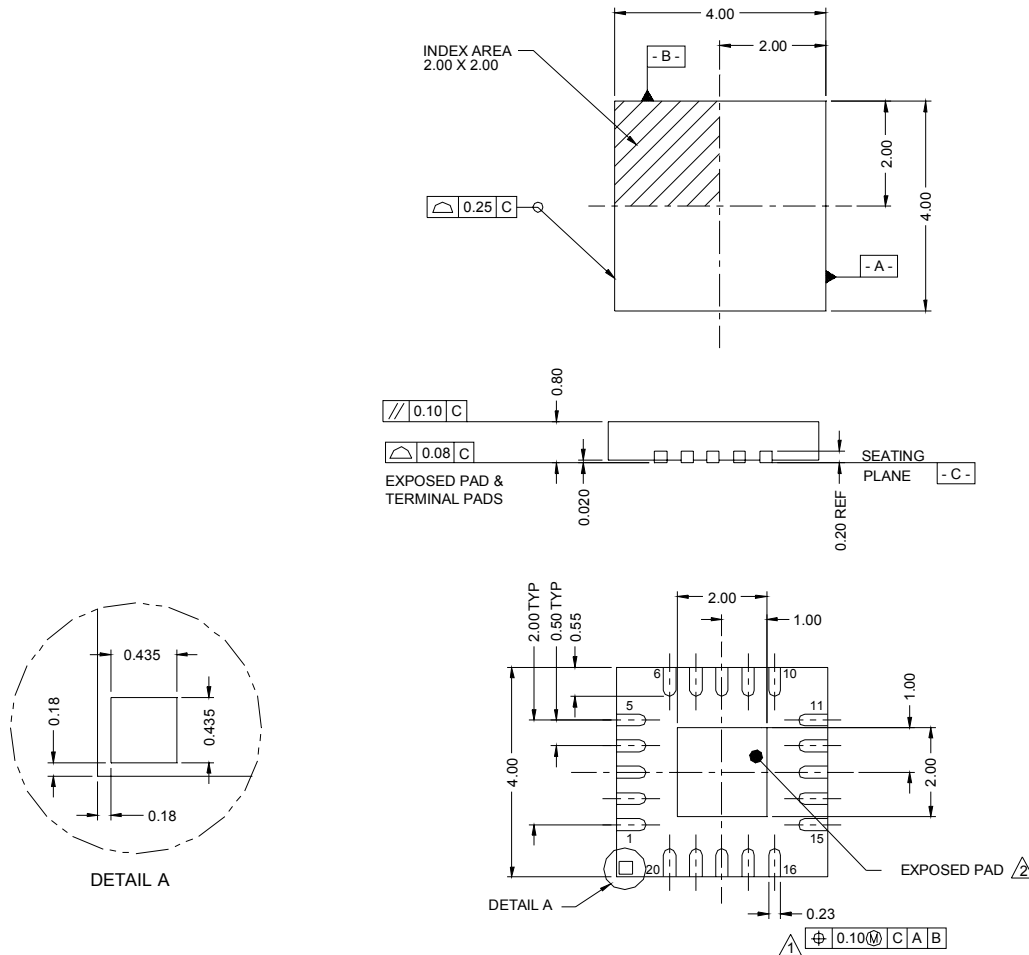
| P/S | LE | PUP2 | PUP1 | Attenuation State   |
|-----|----|------|------|---------------------|
| 0   | 0  | 0    | 0    | Reference Loss      |
| 0   | 0  | 1    | 0    | 8 dB                |
| 0   | 0  | 0    | 1    | 16 dB               |
| 0   | 0  | 1    | 1    | 31 dB               |
| 0   | 1  | X    | X    | Defined by C0.5-C16 |

Note: Power up with LE=1 provides normal parallel operation with C0.5-C16, and PUP1 and PUP2 are not active.



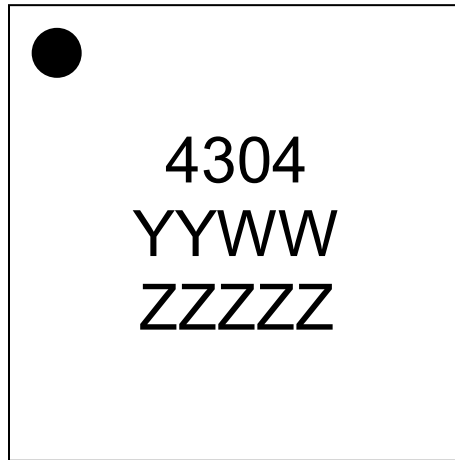


Figure 20. Package Drawing



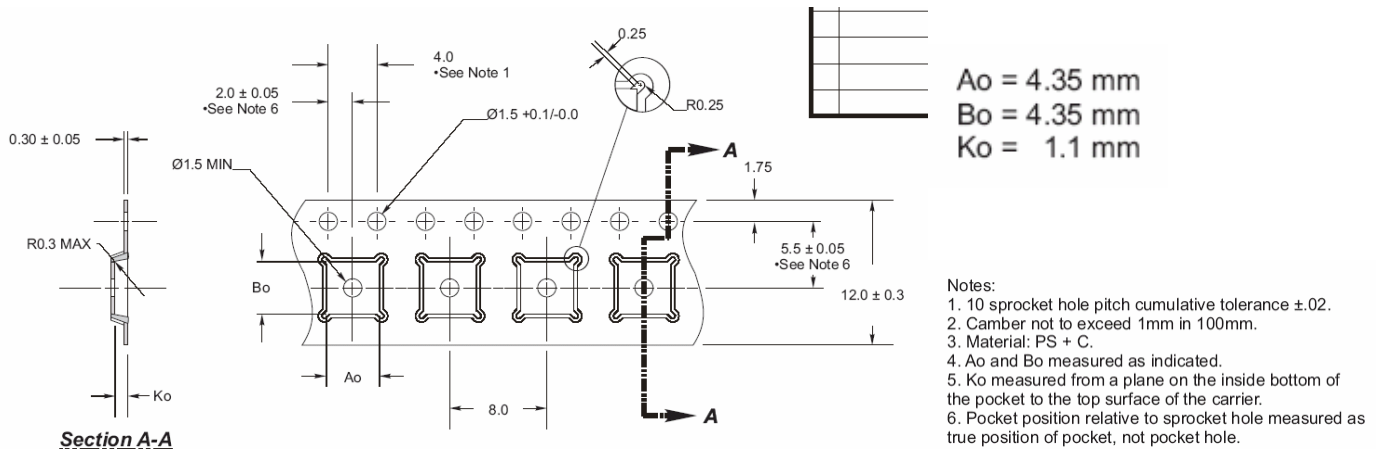
1. Dimension applies to metallized terminal and is measured between 0.25 and 0.30 from terminal tip.
2. Coplanarity applies to the exposed heat sink slug as well as the terminals.
3. Dimensions are in millimeters.

**Figure 21. Marking Specifications**



YYWW = Date Code  
ZZZZZ = Last five digits of PSC Lot Number

**Figure 22. Tape and Reel Drawing**



**Table 10. Ordering Information**

| Order Code | Part Marking | Description               | Package                  | Shipping Method  |
|------------|--------------|---------------------------|--------------------------|------------------|
| 4304-01    | 4304         | PE4304-20MLP 4x4mm-75A    | 20-lead 4x4 mm QFN       | 75 units / Tube  |
| 4304-02    | 4304         | PE4304-20MLP 4x4mm-3000C  | 20-lead 4x4 mm QFN       | 3000 units / T&R |
| 4304-00    | PE4304-EK    | PE4304-20MLP 4x4mm-EK     | Evaluation Kit           | 1 / Box          |
| 4304-51    | 4304         | PE4304G-20MLP 4x4mm-75A   | Green 20-lead 4x4 mm QFN | 75 units / Tube  |
| 4304-52    | 4304         | PE4304G-20MLP 4x4mm-3000C | Green 20-lead 4x4 mm QFN | 3000 units / T&R |

## Sales Offices

### *The Americas*

#### **Peregrine Semiconductor Corporation**

9450 Carroll Park Drive  
San Diego, CA 92121  
Tel: 858-731-9400  
Fax: 858-731-9499

### *Europe*

#### **Peregrine Semiconductor Europe**

Bâtiment Maine  
13-15 rue des Quatre Vents  
F-92380 Garches, France  
Tel: +33-1-4741-9173  
Fax : +33-1-4741-9173

#### **Space and Defense Products**

##### **Americas:**

Tel: 858-731-9453

##### **Europe, Asia Pacific:**

180 Rue Jean de Guiramand  
13852 Aix-En-Provence Cedex 3, France  
Tel: +33-4-4239-3361  
Fax: +33-4-4239-7227

### *North Asia Pacific*

#### **Peregrine Semiconductor K.K.**

Teikoku Hotel Tower 10B-6  
1-1-1 Uchisaiwai-cho, Chiyoda-ku  
Tokyo 100-0011 Japan  
Tel: +81-3-3502-5211  
Fax: +81-3-3502-5213

#### **Peregrine Semiconductor, Korea**

#B-2402, Kolon Tripolis, #210  
Geumgok-dong, Bundang-gu, Seongnam-si  
Gyeonggi-do, 463-480 S. Korea  
Tel: +82-31-728-4300  
Fax: +82-31-728-4305

### *South Asia Pacific*

#### **Peregrine Semiconductor, China**

Shanghai, 200040, P.R. China  
Tel: +86-21-5836-8276  
Fax: +86-21-5836-7652

For a list of representatives in your area, please refer to our Web site at: [www.psemi.com](http://www.psemi.com)

## Data Sheet Identification

### **Advance Information**

The product is in a formative or design stage. The data sheet contains design target specifications for product development. Specifications and features may change in any manner without notice.

### **Preliminary Specification**

The data sheet contains preliminary data. Additional data may be added at a later date. Peregrine reserves the right to change specifications at any time without notice in order to supply the best possible product.

### **Product Specification**

The data sheet contains final data. In the event Peregrine decides to change the specifications, Peregrine will notify customers of the intended changes by issuing a DCN (Document Change Notice).

The information in this data sheet is believed to be reliable. However, Peregrine assumes no liability for the use of this information. Use shall be entirely at the user's own risk.

No patent rights or licenses to any circuits described in this data sheet are implied or granted to any third party.

Peregrine's products are not designed or intended for use in devices or systems intended for surgical implant, or in other applications intended to support or sustain life, or in any application in which the failure of the Peregrine product could create a situation in which personal injury or death might occur. Peregrine assumes no liability for damages, including consequential or incidental damages, arising out of the use of its products in such applications.

The Peregrine name, logo, and UTSi are registered trademarks and UltraCMOS and HaRP are trademarks of Peregrine Semiconductor Corp.