



Chipsmall Limited consists of a professional team with an average of over 10 year of expertise in the distribution of electronic components. Based in Hongkong, we have already established firm and mutual-benefit business relationships with customers from,Europe,America and south Asia,supplying obsolete and hard-to-find components to meet their specific needs.

With the principle of "Quality Parts,Customers Priority,Honest Operation,and Considerate Service",our business mainly focus on the distribution of electronic components. Line cards we deal with include Microchip,ALPS,ROHM,Xilinx,Pulse,ON,Everlight and Freescale. Main products comprise IC,Modules,Potentiometer,IC Socket,Relay,Connector.Our parts cover such applications as commercial,industrial, and automotives areas.

We are looking forward to setting up business relationship with you and hope to provide you with the best service and solution. Let us make a better world for our industry!



Contact us

Tel: +86-755-8981 8866 Fax: +86-755-8427 6832

Email & Skype: info@chipsmall.com Web: www.chipsmall.com

Address: A1208, Overseas Decoration Building, #122 Zhenhua RD., Futian, Shenzhen, China



Product Description

This product is a high linearity, 6-bit RF Digital Step Attenuator (DSA) covering a 31.5 dB attenuation range in 0.5 dB steps. The Peregrine 50Ω RF DSA provides a parallel CMOS control interface and it operates on 3-volt to 5-volt supply. It maintains high attenuation accuracy over frequency and temperature and exhibits very low insertion loss and low power consumption. This Peregrine DSA is available in a 4x4 mm 24 lead QFN footprint with an exposed ground paddle.

The PE4309 is manufactured on Peregrine's UltraCMOS™ process, a patented variation of silicon-on-insulator (SOI) technology on a sapphire substrate, offering the performance of GaAs with the economy and integration of conventional CMOS.

Figure 1. Functional Schematic Diagram

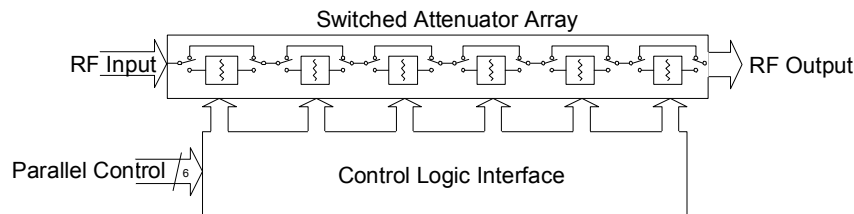

Table 1. Electrical Specifications @ +25°C, V_{DD} = 3.0 V - 5.0 V

Parameter	Test Conditions ⁴	Frequency	Min	Typ	Maximum	Units
Operation Frequency			DC		4000	MHz
Insertion Loss		DC - 2.2 GHz 2.2 - 4.0 GHz	- -	1.6 2.2	2 3.4	dB dB
Attenuation Accuracy	Any Bit or Bit Combination Any Bit or Bit Combination 0.5 - 7.5 dB States ³ 8.0 - 15.5 dB States ³ 16.0 - 31.5 dB States ³	DC ≤ 1.0 GHz 1.0 < 2.2 GHz 2.2 < 3.8 GHz 2.2 < 3.8 GHz 2.2 < 3.8 GHz	- - - - -	- - 0.15 0.7 1.2	±(0.10 + 3% of atten setting), not to exceed +0.20 dB ±(0.15 + 3% of atten setting)	dB dB dB dB
1 dB Compression ²		1 MHz - 2.2 GHz 2.2 - 4.0 GHz	30 -	32 32	- -	dBm dBm
Input IP3 ¹	Two-tone inputs +18 dBm	1 MHz - 2.2 GHz 2.2 - 4.0 GHz	- -	52 45	- -	dBm dBm
Return Loss		DC - 2.2 GHz 2.2 - 4.0 GHz	15 10	20 20	- -	dB dB
Switching Speed	50% of control voltage to 90% of final attenuation level		-	-	1	µs

Notes: 1. Device Linearity will begin to degrade below 5 MHz.

2. Note Absolute Maximum in Table 4.

3. See Figures 12 and 13 for typical attenuation error.

4. Measurements made in a 50 ohm system (see Figure 4, Test Circuit Block Diagram). Resistors (R2, R3, R5, R6, R7) with a value of 10K-ohm are used to decouple the RF path from the control inputs.

Figure 2. Package Type

4x4 mm 24-Lead QFN



Figure 3. Pin Configuration (Top View)

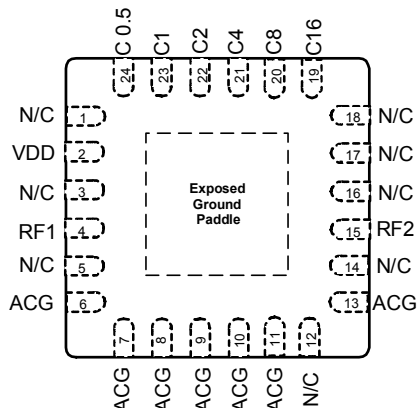

Table 2. Pin Descriptions

Pin No.	Pin Name	Description
1	N/C ⁷	No Connect
2	V _{DD}	Power supply pin
3	N/C ⁵	No Connect
4	RF1	RF port
5	N/C ⁵	No Connect
6	ACG ⁶	AC Ground connection
7	ACG ⁶	AC Ground connection
8	ACG ⁶	AC Ground connection
9	ACG ⁶	AC Ground connection
10	ACG ⁶	AC Ground connection
11	ACG ⁶	AC Ground connection
12	N/C ⁷	No Connect
13	ACG ⁶	AC Ground connection
14	N/C ⁵	No Connect
15	RF2	RF port
16	N/C ⁵	No Connect
17	N/C ⁵	No Connect
18	N/C ⁵	No Connect
19	C16	Attenuation control bit, 16 dB
20	C8	Attenuation control bit, 8 dB
21	C4	Attenuation control bit, 4 dB
22	C2	Attenuation control bit, 2 dB
23	C1	Attenuation control bit, 1 dB
24	C0.5	Attenuation control bit, 0.5 dB
Paddle	GND	Ground for proper operation

Notes: 5. For improved RF performance these No Connect pins can be connected to RF ground.

6. Pins can either be grounded directly or through coupling capacitors

7. Pin can either be grounded or No Connect

Exposed Solder Pad Connection

The exposed solder pad on the bottom of the package must be grounded for proper device operation.

Table 3. Operating Ranges

Parameter	Min	Typ	Max	Units
V _{DD} Power Supply Voltage	3.0	3.3	5.5	V
I _{DD} Power Supply Current		100	250	μA
P _{IN} Input power (50Ω)			+24	dBm

Table 4. Absolute Maximum Ratings

Symbol	Parameter/Conditions	Min	Max	Units
V _{DD}	Power supply voltage	-0.3	6.0	V
V _I	Voltage on any DC input	-0.3	6.0	V
T _{ST}	Storage temperature range	-65	150	°C
T _{OP}	Operating temperature range	-40	85	°C
P _{IN}	Input power (50Ω)		30	dBm
V _{ESD}	ESD voltage (Human Body Model)		2000	V

Electrostatic Discharge (ESD) Precautions

When handling this UltraCMOS™ device, observe the same precautions that you would use with other ESD-sensitive devices. Although this device contains circuitry to protect it from damage due to ESD, precautions should be taken to avoid exceeding the rate specified in Table 4.

Latch-Up Avoidance

Unlike conventional CMOS devices, UltraCMOS™ devices are immune to latch-up.

Switching Frequency

The PE4309 has a maximum 25 kHz switching rate.

Table 5. Control Voltage

State	Bias Condition
Low	0 to +1.0 Vdc at 2 μA (typ)
High	+2.0 to +5 Vdc at 10 μA (typ)

The standard 3V or 5V CMOS control logic is independent of supply voltage.

Table 6. Truth Table

C16	C8	C4	C2	C1	C0.5	Attenuation State
1	1	1	1	1	1	Reference Loss (IL)
1	1	1	1	1	0	0.5 dB
1	1	1	1	0	1	1 dB
1	1	1	0	1	1	2 dB
1	1	0	1	1	1	4 dB
1	0	1	1	1	1	8 dB
0	1	1	1	1	1	16 dB
0	0	0	0	0	0	31.5 dB

Figure 4. Test Circuit Block Diagram
Peregrine Specification 102-0371

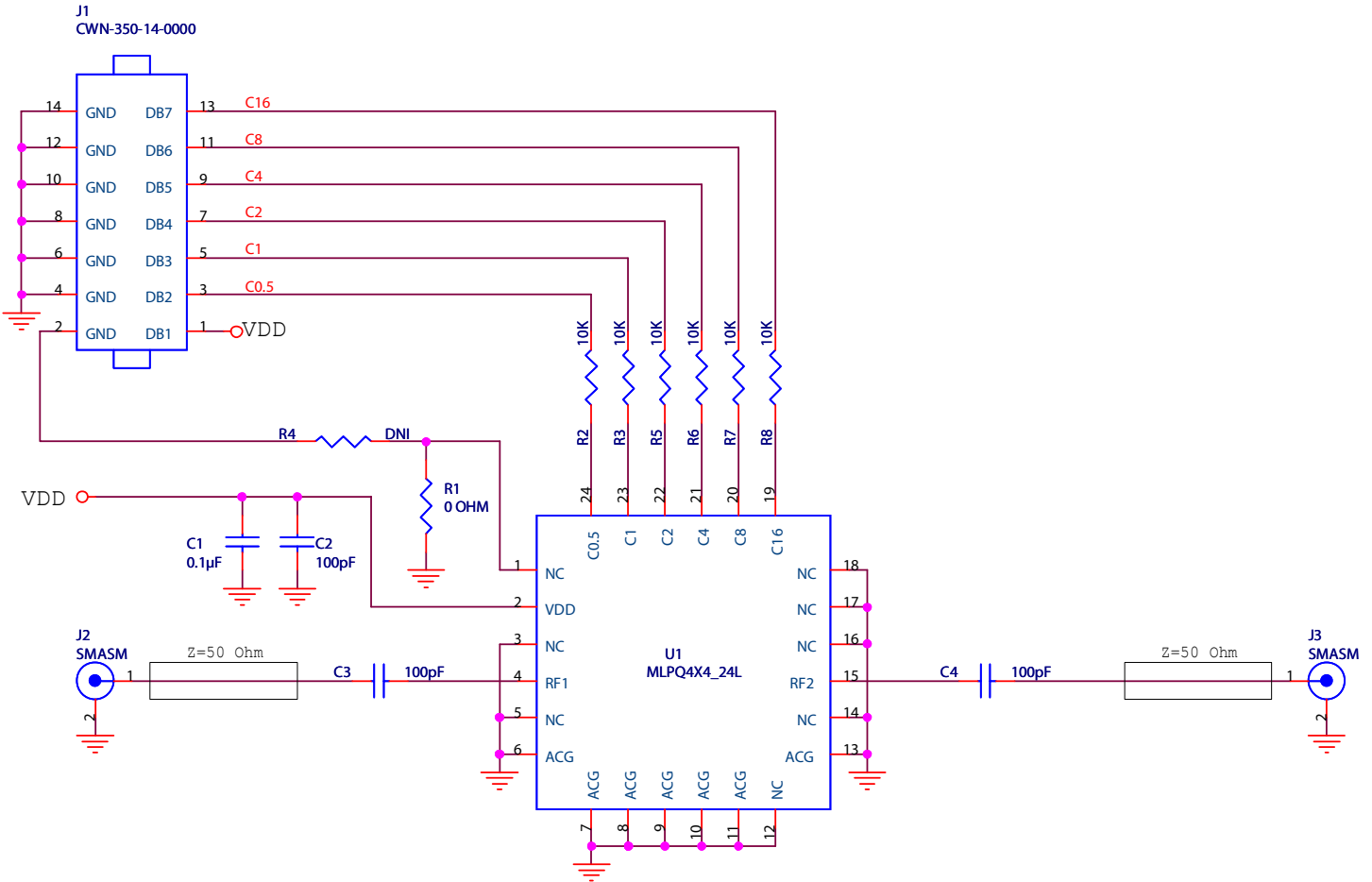

ECT BP050-0024UJ03 4x4
MLP 24 Ld Socket

Evaluation Kit

The Digital Attenuator Evaluation Kit board was designed to ease customer evaluation of the PE4309 Digital Step Attenuator. Connect J2 by mini clip to Vdd to power the IC. Connect J8 by mini clip to power the evaluation board support circuits. The control bits for the six parallel data inputs (C0.5 to C16) are controlled using S2-S7 to select bits or bit combinations. This allows any attenuation setting to be specified as shown in Table 6.

The de-embed trace (J6 to J7) estimates the PCB insertion loss for removal from the evaluation board measurement data.

To evaluate using customer software, J1 can be installed using a standard 0.100 IDC header (some circuit modification required, see schematic).

The ability to supply different voltages for the Control circuitry (using J8) and IC Vdd (using J2) circuits allows for evaluation of circuits using different control vs. supply voltages.

Figure 5. Evaluation Board Layout
Peregrine Specification 101/0299

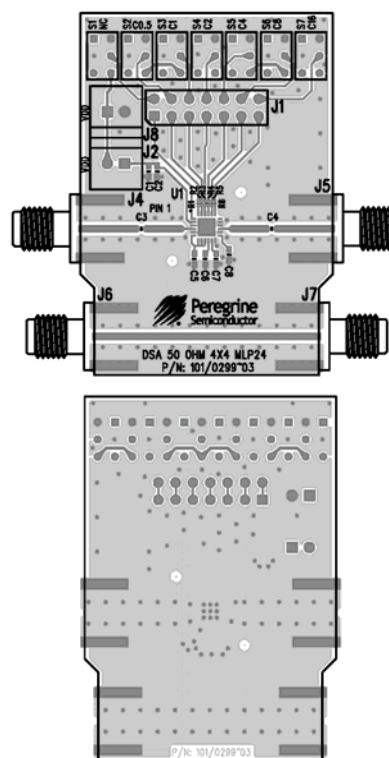
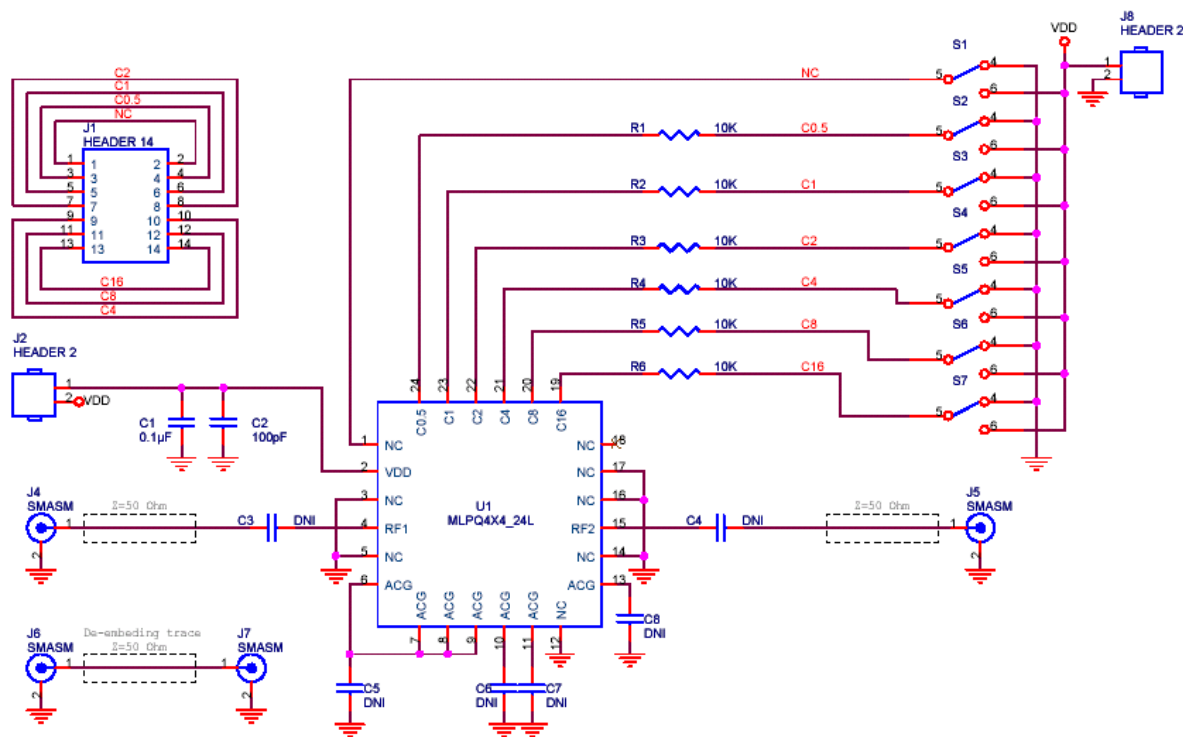

Figure 6. Evaluation Board Schematic
Peregrine Specification 102/0366



Typical Performance Data

Figure 7. Insertion Loss, $V_{dd} = 3.0\text{ V}$

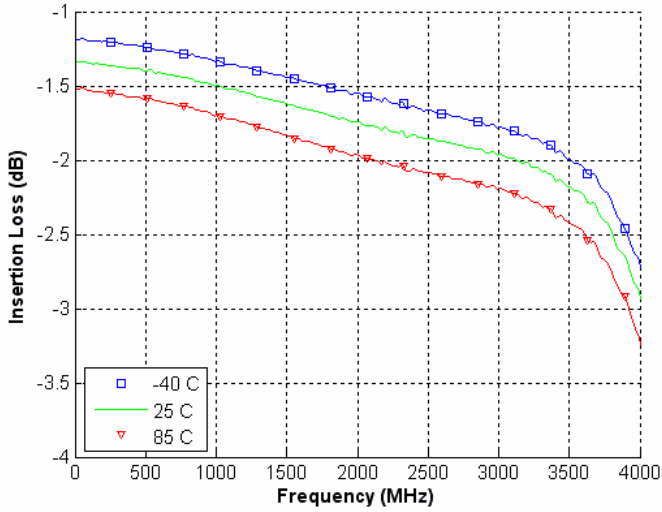

Figure 8. Attenuation at Major Steps

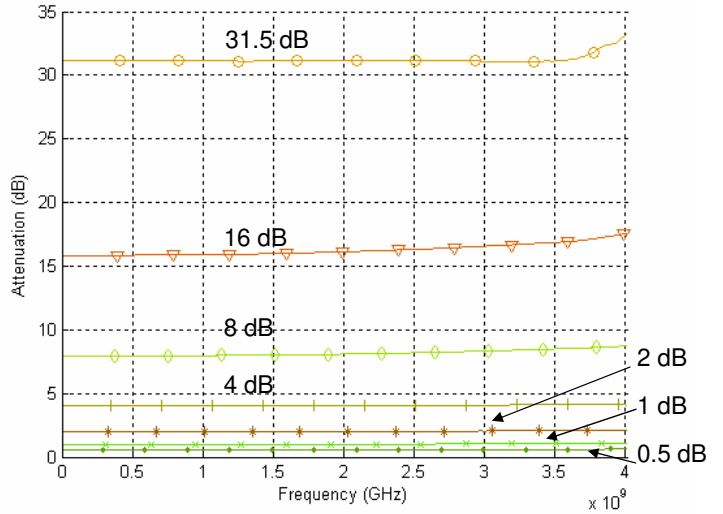

Figure 9. Input Return Loss at Major Attenuation Steps

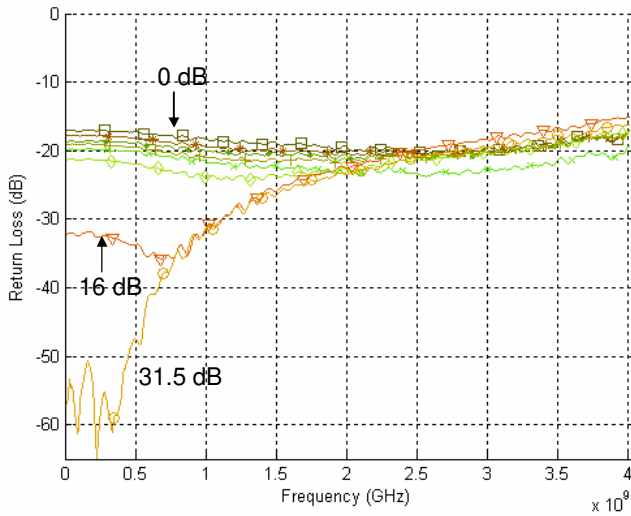
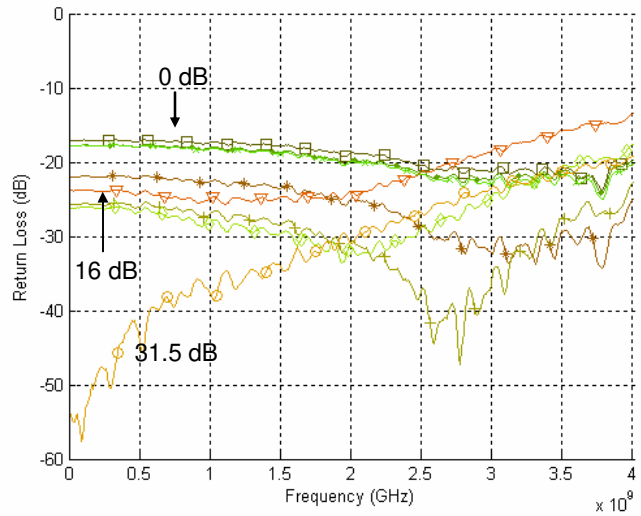

Figure 10. Output Return Loss at Major Attenuation Steps



Typical Performance Data

Figure 11. Attenuation Error Vs. Frequency

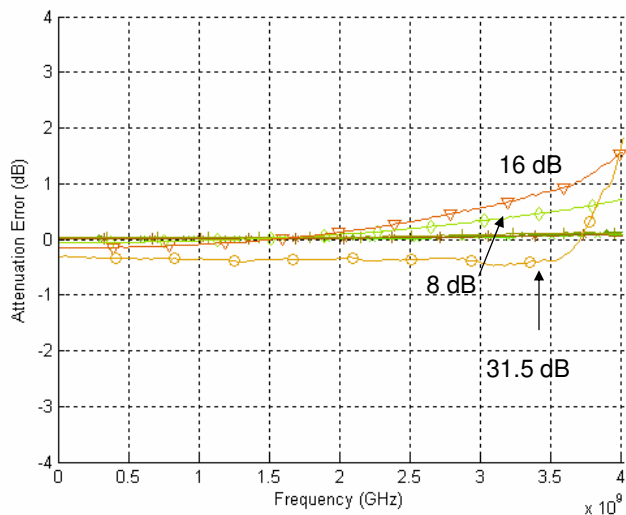

Figure 12. Attenuation Error vs. Setting: Low Frequency

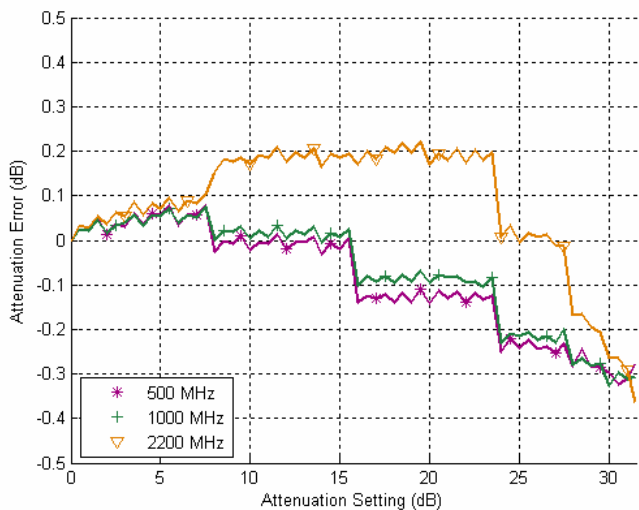

Figure 13. Attenuation Error vs. Setting: High Frequency

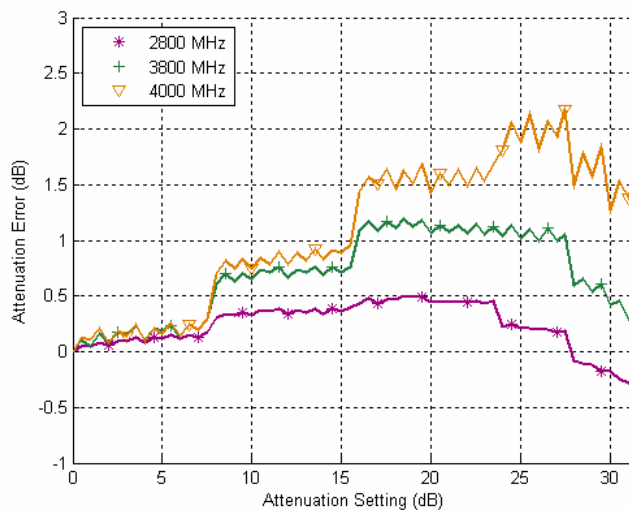
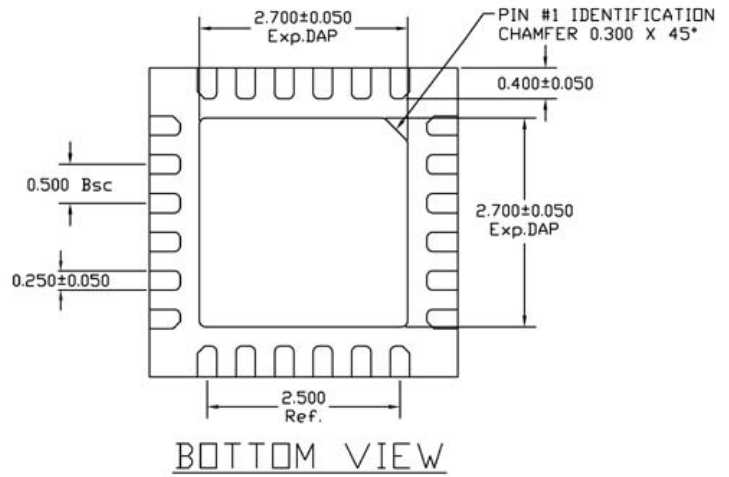
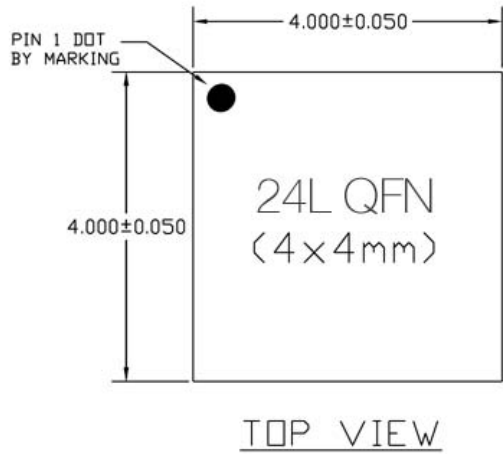

Figure 16. Package Drawing



		QFN 4x4 mm
A	MAX	0.900
	NOM	0.850
	MIN	0.800

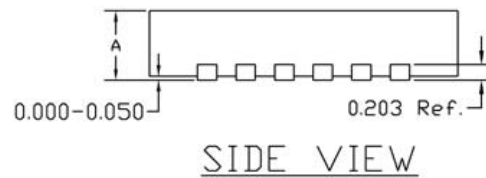
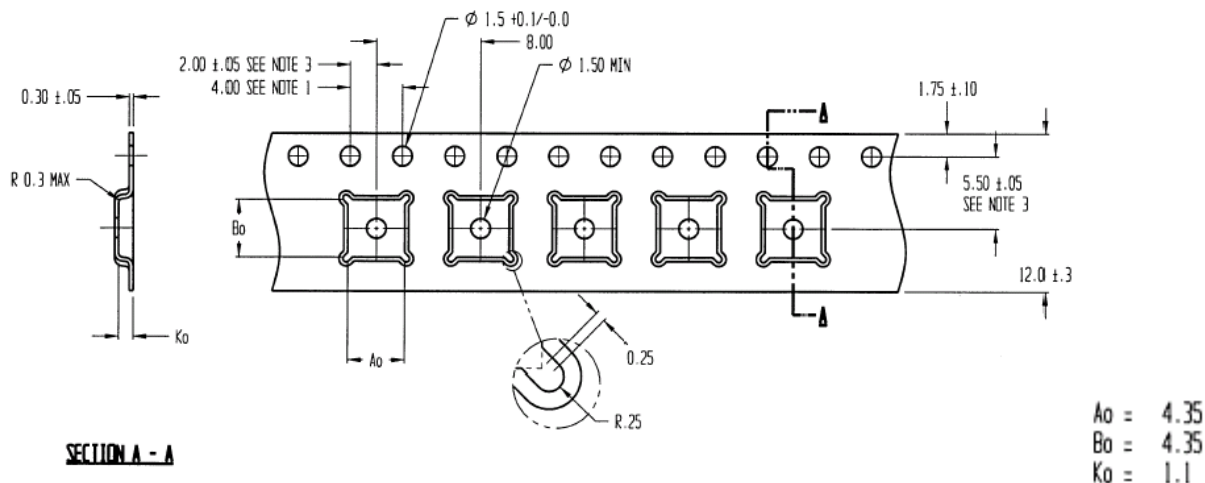

Figure 17. Tape and Reel Drawing



NOTES:

1. 10 SPROCKET HOLE PITCH CUMULATIVE TOLERANCE ± 0.2
2. CAMBER IN COMPLIANCE WITH EIA 481
3. POCKET POSITION RELATIVE TO SPROCKET HOLE MEASURED AS TRUE POSITION OF POCKET, NOT POCKET HOLE

Figure 18. Marking Specifications

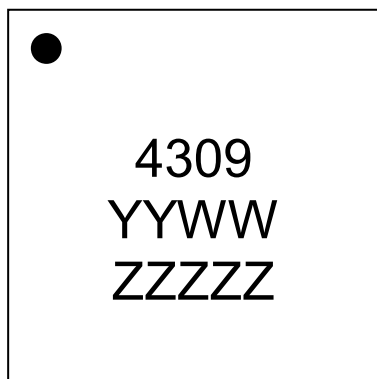

YYWW = Date Code
ZZZZZ = Last five digits of Lot Number

Table 7. Ordering Information

Order Code	Part Marking	Description	Package	Shipping Method
4309-00	PE4309-EK	PE4309-24QFN 4x4mm-EK	Evaluation Kit	1 / Box
4309-51	4309	PE4309G-24QFN 4x4mm-75A	Green 24-lead 4x4mm QFN	75 units / Tube
4309-52	4309	PE4309G-24QFN 4x4mm-3000C	Green 24-lead 4x4mm QFN	3000 units / T&R

Sales Offices

The Americas

Peregrine Semiconductor Corporation

9380 Carroll Park Drive
San Diego, CA 92121
Tel: 858-731-9400
Fax: 858-731-9499

Europe

Peregrine Semiconductor Europe

Bâtiment Maine
13-15 rue des Quatre Vents
F-92380 Garches, France
Tel: +33-1-4741-9173
Fax : +33-1-4741-9173

Space and Defense Products

Americas:

Tel: 858-731-9453

Europe, Asia Pacific:

180 Rue Jean de Guiramand
13852 Aix-En-Provence Cedex 3, France
Tel: +33-4-4239-3361
Fax: +33-4-4239-7227

Peregrine Semiconductor, Asia Pacific (APAC)

Shanghai, 200040, P.R. China
Tel: +86-21-5836-8276
Fax: +86-21-5836-7652

Peregrine Semiconductor, Korea

#B-2607, Kolon Tripolis, 210
Geumgok-dong, Bundang-gu, Seongnam-si
Gyeonggi-do, 463-943 South Korea
Tel: +82-31-728-3939
Fax: +82-31-728-3940

Peregrine Semiconductor K.K., Japan

Teikoku Hotel Tower 10B-6
1-1-1 Uchisaiwai-cho, Chiyoda-ku
Tokyo 100-0011 Japan
Tel: +81-3-3502-5211
Fax: +81-3-3502-5213

For a list of representatives in your area, please refer to our Web site at: www.psemi.com

Data Sheet Identification

Advance Information

The product is in a formative or design stage. The data sheet contains design target specifications for product development. Specifications and features may change in any manner without notice.

Preliminary Specification

The data sheet contains preliminary data. Additional data may be added at a later date. Peregrine reserves the right to change specifications at any time without notice in order to supply the best possible product.

Product Specification

The data sheet contains final data. In the event Peregrine decides to change the specifications, Peregrine will notify customers of the intended changes by issuing a DCN (Document Change Notice).

The information in this data sheet is believed to be reliable. However, Peregrine assumes no liability for the use of this information. Use shall be entirely at the user's own risk.

No patent rights or licenses to any circuits described in this data sheet are implied or granted to any third party.

Peregrine's products are not designed or intended for use in devices or systems intended for surgical implant, or in other applications intended to support or sustain life, or in any application in which the failure of the Peregrine product could create a situation in which personal injury or death might occur. Peregrine assumes no liability for damages, including consequential or incidental damages, arising out of the use of its products in such applications.

The Peregrine name, logo, and UTSi are registered trademarks and UltraCMOS, HaRP and MultiSwitch are trademarks of Peregrine Semiconductor Corp.