



Chipsmall Limited consists of a professional team with an average of over 10 year of expertise in the distribution of electronic components. Based in Hongkong, we have already established firm and mutual-benefit business relationships with customers from,Europe,America and south Asia,supplying obsolete and hard-to-find components to meet their specific needs.

With the principle of “Quality Parts,Customers Priority,Honest Operation,and Considerate Service”,our business mainly focus on the distribution of electronic components. Line cards we deal with include Microchip,ALPS,ROHM,Xilinx,Pulse,ON,Everlight and Freescale. Main products comprise IC,Modules,Potentiometer,IC Socket,Relay,Connector.Our parts cover such applications as commercial,industrial, and automotives areas.

We are looking forward to setting up business relationship with you and hope to provide you with the best service and solution. Let us make a better world for our industry!



## Contact us

Tel: +86-755-8981 8866 Fax: +86-755-8427 6832

Email & Skype: info@chipsmall.com Web: www.chipsmall.com

Address: A1208, Overseas Decoration Building, #122 Zhenhua RD., Futian, Shenzhen, China



## Single and Dual-Channel Safety Edge Controllers

for use with All Safety Edges and Safety Bumpers

- Power requirements
  - 120 VAC or 24 VDC is acceptable for the SCC-1224 single channel units
  - 24 VDC is acceptable for SCC-2124/2224 dual channel units
- Inputs
  - Single channel units accept a single two-wire edge or bumper system
  - Dual channel units accept 1 or 2 two-wire edge or bumper systems
- Outputs
  - Single channel units have two safety outputs and one auxiliary output for signaling
  - Dual channel units have either 1 or 2 safety outputs, and either 1 or 2 auxiliary outputs with DIP switch selection for input channel relationship
- External Device Monitoring –EDM is provided on all units with a N/C loop between Z1 and Z2
- Monitored Reset Modes
  - Monitored manual reset mode that requires closure of the reset circuit followed by opening of the circuit is available on all units
  - Automatic reset mode that occurs upon closure of the reset circuit is available on all units
- Delayed Auxiliary Output – Delayed opening of the auxiliary output for reversal of a door or gate may be selected on all units except SCC1224ND



E

## Specifications

	SCC-1224 & SCC-1224ND DIN Mount, 115 VAC or 24 VAC/DC Single Input, Safety Output and Aux.	SCC-2124 DIN Mount, 24 VDC Dual Independent Inputs, Single Safety Output and Aux.	SCC-2224 DIN Mount, 24 VDC Dual Independent Inputs, Safety Outputs and Aux.
<b>Performance</b>			
Category 3 Safety Device:	Yes		
Operating Area:	Up to 5 sensing devices with a total cable length of max. 25 m in series	Up to 5 sensing devices with a total cable length of max. 25 m in series	
Response Time:	< 13 msec.	< 2 ms	
Indications:	Power – Main power supply = Green Actuate – Edge is depressed = Yellow Fault – Detect an irregular signal = Red Aux. Actuate – Activate Aux. output = Orange	Power – Main power supply = Green CH1 – Edge is depressed = Yellow CH2 – Edge is depressed = Yellow Aux. Relay 1 – Activate Aux. output = Orange	Power – Main power supply = Green CH1 – Edge is depressed = Yellow CH2 – Edge is depressed = Yellow Aux. Relay 1 – Activate Aux. output = Orange Aux. Relay 2 – Activate Aux. output = Orange
Operational Modes (Selectable):	Automatic Start Start/Restart Interlock		
<b>Electrical</b>			
Power Input:	115 VAC, 50/60 Hz, 3 VA or 24 VAC/DC ± 10%, 1.5 W	24 VAC/DC ± 10%, 1 W	
Safety Output:	2 N/O Relay	1 N/O Relay (13 = input + 24 VDC, +10/-50%)	2 N/O Relay (+24 VDC Internally Connected)
Maximum Switched Current:	4 A, 250 VAC / 4 A, 30 VDC	2 ADC, 10 to 26.4 VDC	2 ADC, 10 to 26.4 VDC
Auxiliary Relay Output:	SCC-1224: Activates after approx. 1 s for approx. 3 s if the sensing device is actuated or faulty; SCC-1224ND: Activates if the sensing device is actuated or if a sensing device fault is detected	1 N/O When using the NO DELAY function, the auxiliary relay switches synchronously with the safety edge actuation	2 N/O When using the NO DELAY function, the auxiliary relay switches synchronously with the safety edge actuation
Maximum Switched Current:	4A, 250 VAC / 4A, 30 VDC	2A AC/DC, 50 V AC/DC	2A AC/DC, 50 V AC/DC
Terminal Blocks:	Cage Clamp Terminal Strip Wire Size 0.75-1.5 mm <sup>2</sup>		
Input Connections:	1-2 wire edge sensor circuit		
Input Resistance:	8.2 K ohm		
Input Voltage:	6 V ±2%		
Input Current:	1 mA		
<b>Mechanical</b>			
Enclosure:	Polyamide PA6.6, Self-extinguishing in accordance with UL-94-V2		
Mounting:	35 mm DIN rail		
<b>Environmental</b>			
Protection Rating:	IP20		
Operating Temperature:	-20 to 55°C (-4 to 131°F)		
Shipping Weight:	210 g (7.4 oz.)	160 g (5.6 oz.)	
Standards Conformity:	CE, TUV		
Designed to Meet or Exceed:	Category 3, EN13849-1		

Specifications are subject to change without notice.

E

Dimensions

(mm/in.)

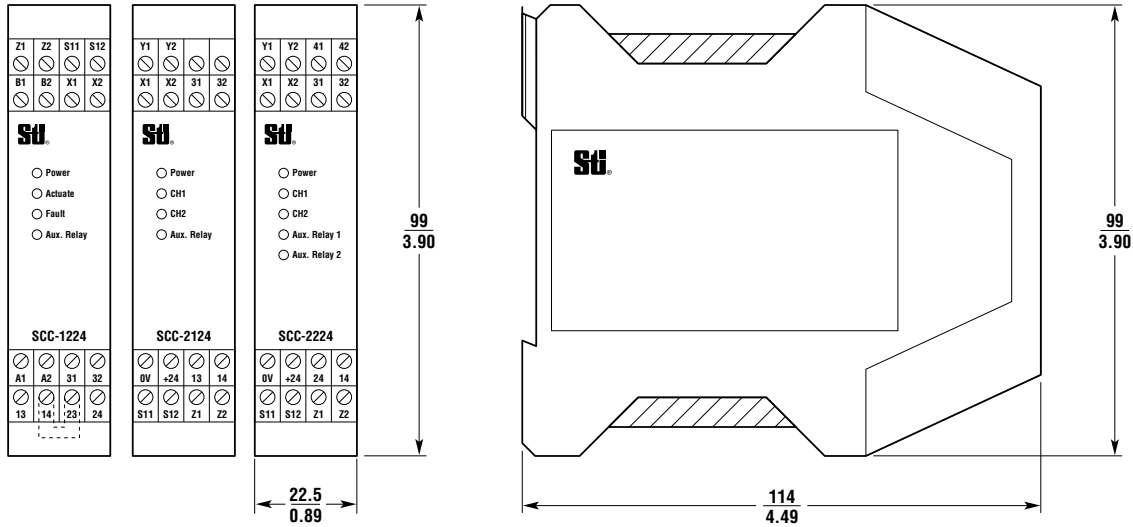

Installation

Mounting

The SCC controllers are DIN rail mounted.

Wiring

As with any electrical apparatus, caution must be used when installing, connecting and operating the SCC controllers and safety edges. Please observe all local electrical codes.

SCC-1224 and SCC-1224ND

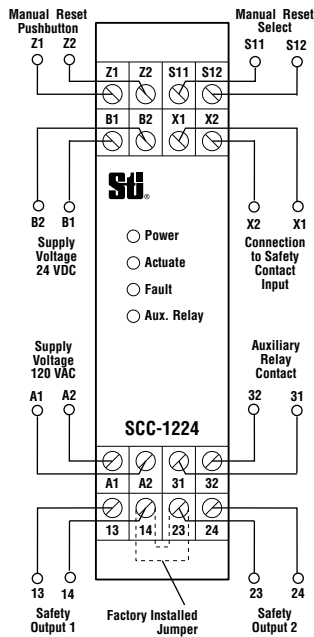

SCC-2124 and SCC-2224

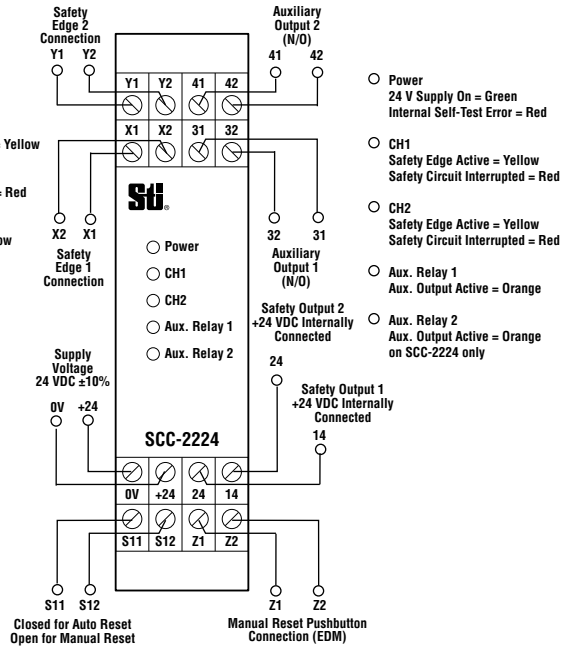

Ordering

Description	Model Number	Part Number
Single-Channel Safety Edge Din-Mount Controller for use with all safety edges, 120 VAC or 24 VDC; Auxiliary contact closes on activation of safety edge for 2 to 3 seconds then opens (even if edge remains activated)	SCC-1224	43872-0020
Single-Channel Safety Edge Din-Mount Controller for use with all safety edges, 120 VAC or 24 VDC; Auxiliary contact closes when the edge is activated and remains closed as long as the edge is activated	SCC-1224ND	43872-0021
Dual-Channel Safety Edge Din-Mount Controller for use with all safety edges, 24 VDC; One safety output and one auxiliary output dip switch selectable for delayed opening	SCC-2124	43872-0040
Dual-Channel Safety Edge Din-Mount Controller for use with all safety edges, 24 VDC; Two safety outputs and two auxiliary outputs dip switch selectable for delayed opening	SCC-2224	43872-0050

For information on Safety Edges, see page E2

For information on Safety Bumpers, see page E12