



Chipsmall Limited consists of a professional team with an average of over 10 year of expertise in the distribution of electronic components. Based in Hongkong, we have already established firm and mutual-benefit business relationships with customers from,Europe,America and south Asia,supplying obsolete and hard-to-find components to meet their specific needs.

With the principle of “Quality Parts,Customers Priority,Honest Operation,and Considerate Service”,our business mainly focus on the distribution of electronic components. Line cards we deal with include Microchip,ALPS,ROHM,Xilinx,Pulse,ON,Everlight and Freescale. Main products comprise IC,Modules,Potentiometer,IC Socket,Relay,Connector.Our parts cover such applications as commercial,industrial, and automotives areas.

We are looking forward to setting up business relationship with you and hope to provide you with the best service and solution. Let us make a better world for our industry!



Contact us

Tel: +86-755-8981 8866 Fax: +86-755-8427 6832

Email & Skype: info@chipsmall.com Web: www.chipsmall.com

Address: A1208, Overseas Decoration Building, #122 Zhenhua RD., Futian, Shenzhen, China



MARKETING SALES DRAWING
DIMENSIONS IN INCHES - DO NOT SCALE THIS DRAWING
DIMENSIONS IN METRIC []

Electrical Testing
per Tusonix standard
test plans and Mil-Std-202
Test Methods.

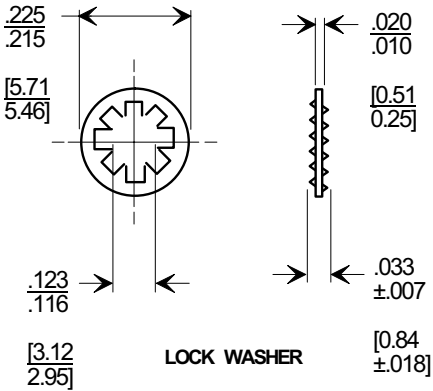
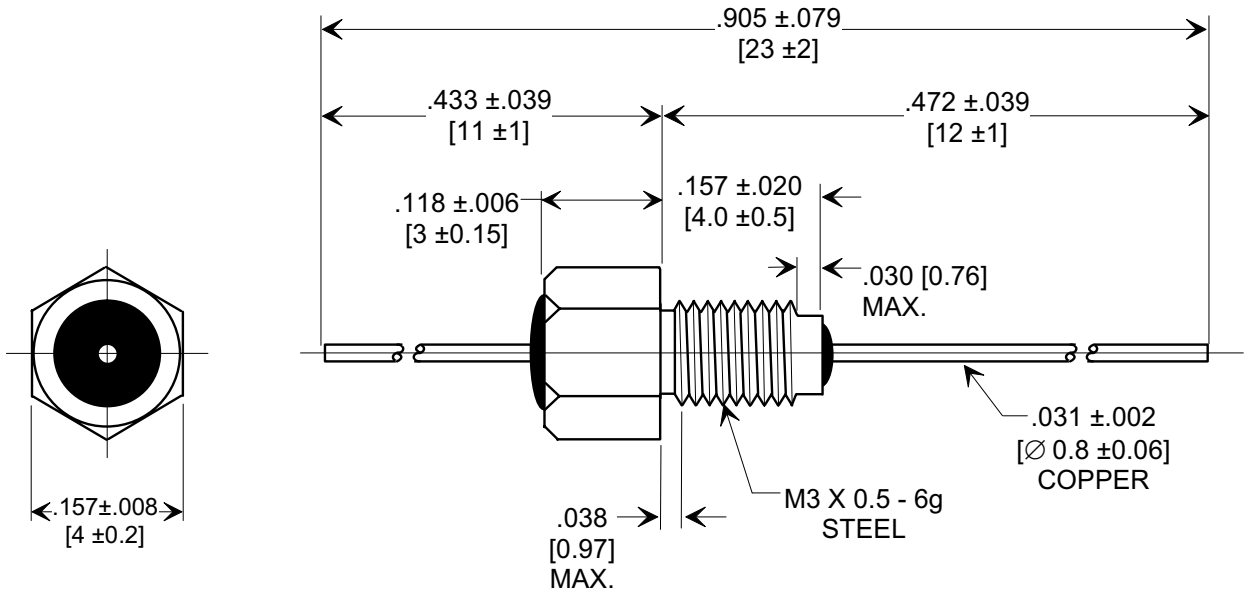
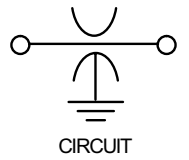
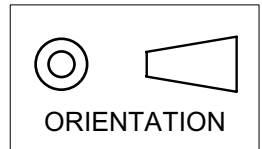

NOTES:

1. TUSONIX STANDARD PART NUMBER: 4400-091.
TUSONIX RoHS COMPLIANT PART NUMBER: 4400-091 LF.
CUSTOMER MUST SPECIFY STANDARD OR RoHS PART NUMBER WHEN ORDERING.
2. MATERIALS: BUSHING; SILVER PLATED. LEAD; SILVER PLATED.
3. PART MARKING: TRADEMARK AND VARIATION NUMBER ON HEX FLATS. STANDARD PART: BLACK INK. RoHS PART: GREEN INK.
4. OPERATING TEMP. RANGE: -55°C TO +125°C.
5. MAX. RECOMMENDED SOLDERING TEMPERATURE : 260° C.
6. SUPPLIED WITH SILVER PLATED INTERNAL TOOTH LOCK WASHER.
7. MAX. RECOMMENDED MOUNTING TORQUE : 2.0 Lb. in. [.226 Nm.].

CAP.(pf)	TOLERANCE	DC WORKING VOLTAGE		DC CURRENT (AMPS)	I.R. MIN. @ 100 (VDC)	DWV (VDC)	MIN. NO LOAD INSERTION LOSS (db) @ 25°C PER MIL-STD-220				
		85°C	125 °C				1 MHz	10 MHz	100 MHz	1 GHz	10 GHz
1,000	GMV	300	200	10	10 G Ω	500	----	5	20	35	45

REVISION RECORD

Original Release	0
C.O. 19980908-3-03	
ADDED IR, ADDED & REVISED NOTES. S.M. 12-01-05	
20051128-1-11	1

--TOLERANCES-- Unless Otherwise Specified		Title BUSHING STYLE EMI FILTER
DECIMAL ± NOTED		
ANGLES ±		
TUSONIX TUCSON, ARIZONA		Drawn S.M. 09-11-98
		Approved J.Mc. 09-11-98
		A 4400-091

X-2015 Rev-0