



Chipsmall Limited consists of a professional team with an average of over 10 year of expertise in the distribution of electronic components. Based in Hongkong, we have already established firm and mutual-benefit business relationships with customers from,Europe,America and south Asia,supplying obsolete and hard-to-find components to meet their specific needs.

With the principle of “Quality Parts,Customers Priority,Honest Operation,and Considerate Service”,our business mainly focus on the distribution of electronic components. Line cards we deal with include Microchip,ALPS,ROHM,Xilinx,Pulse,ON,Everlight and Freescale. Main products comprise IC,Modules,Potentiometer,IC Socket,Relay,Connector.Our parts cover such applications as commercial,industrial, and automotives areas.

We are looking forward to setting up business relationship with you and hope to provide you with the best service and solution. Let us make a better world for our industry!



## Contact us

Tel: +86-755-8981 8866 Fax: +86-755-8427 6832

Email & Skype: info@chipsmall.com Web: www.chipsmall.com

Address: A1208, Overseas Decoration Building, #122 Zhenhua RD., Futian, Shenzhen, China



THIS DRAWING IS UNPUBLISHED. RELEASED FOR PUBLICATION  
 © COPYRIGHT BY TYCO ELECTRONICS CORPORATION. ALL INTERNATIONAL RIGHTS RESERVED.

LOC	DIST	REVISIONS					
DF	SO	P	LTR	DESCRIPTION	DATE	DWN	APVD
		C		REV PER ECO-10-002917	16FEB10	PY	DE

RECOMMENDED KEYING		
OPTION	A	B
#1	LONG	EMPTY
#2	EMPTY	LONG
#3	SHORT	SHORT

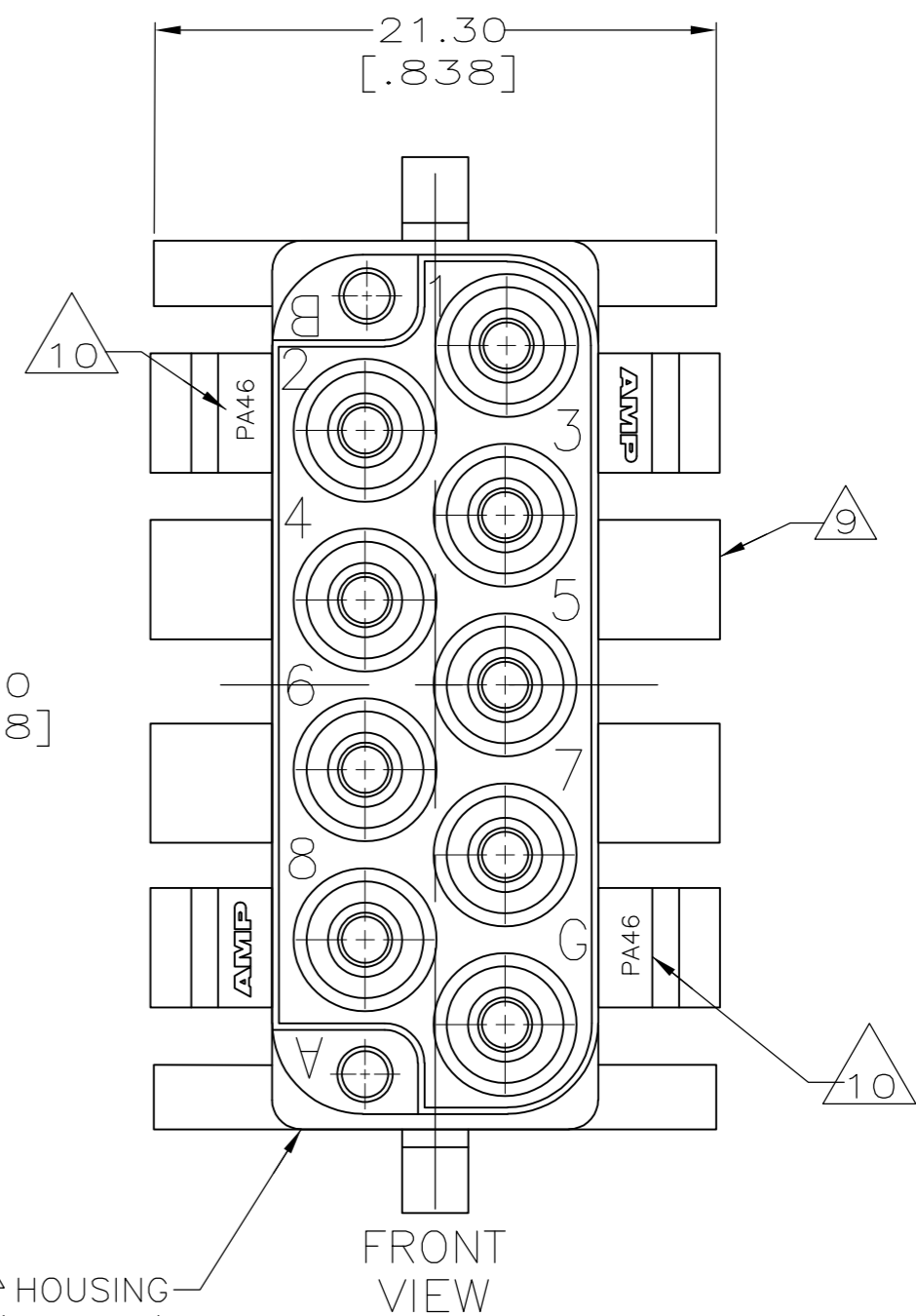
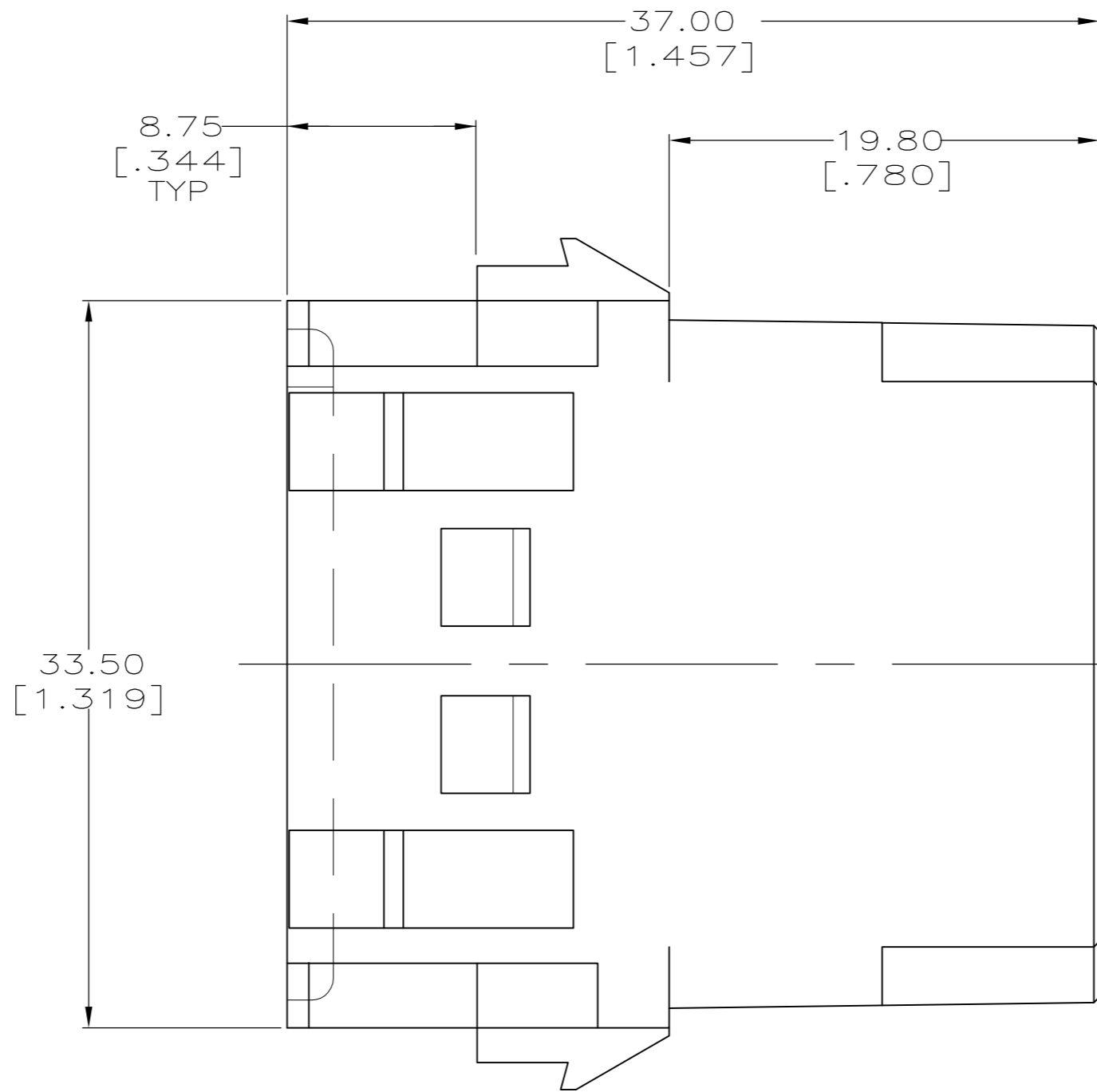
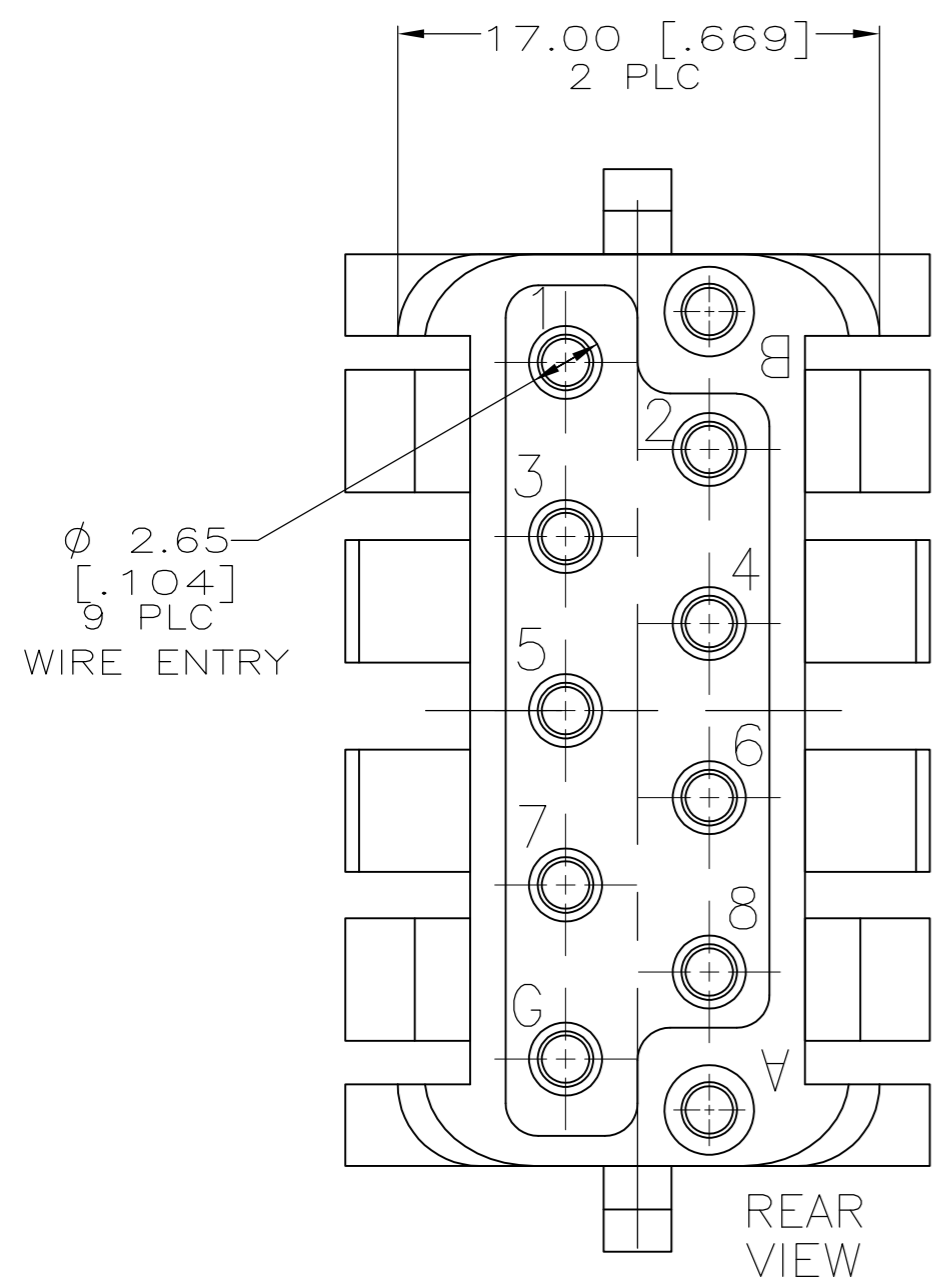
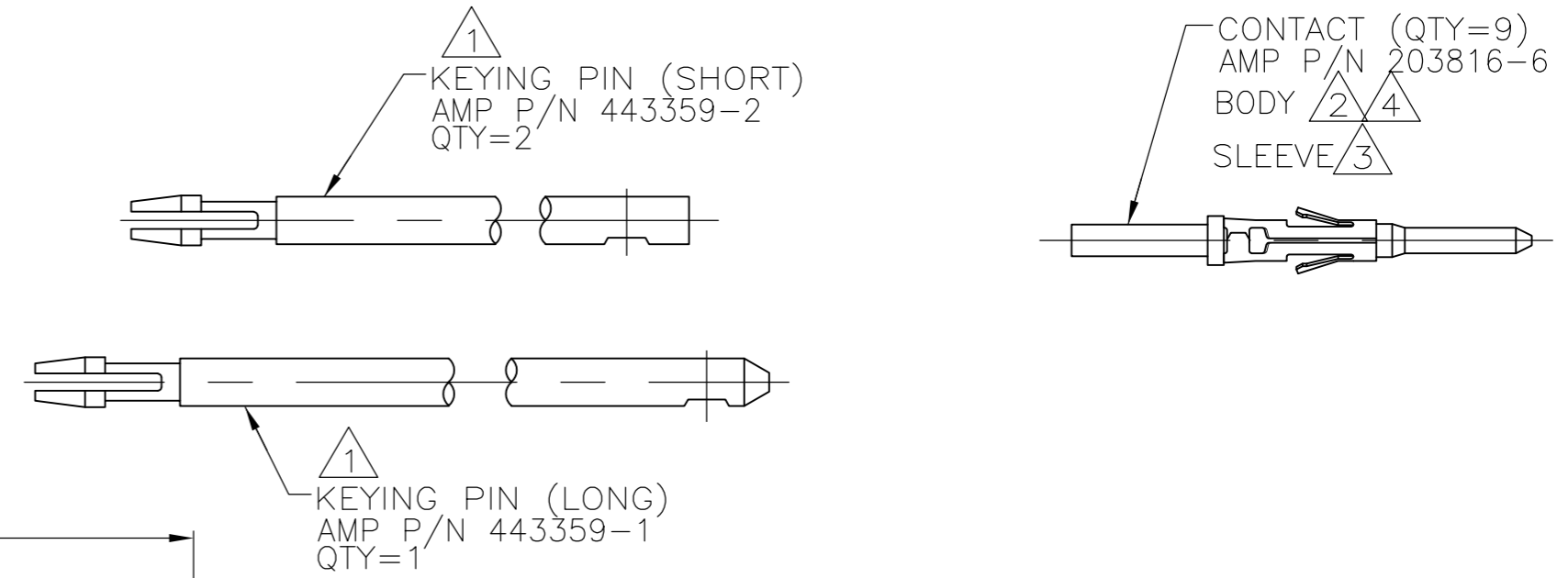
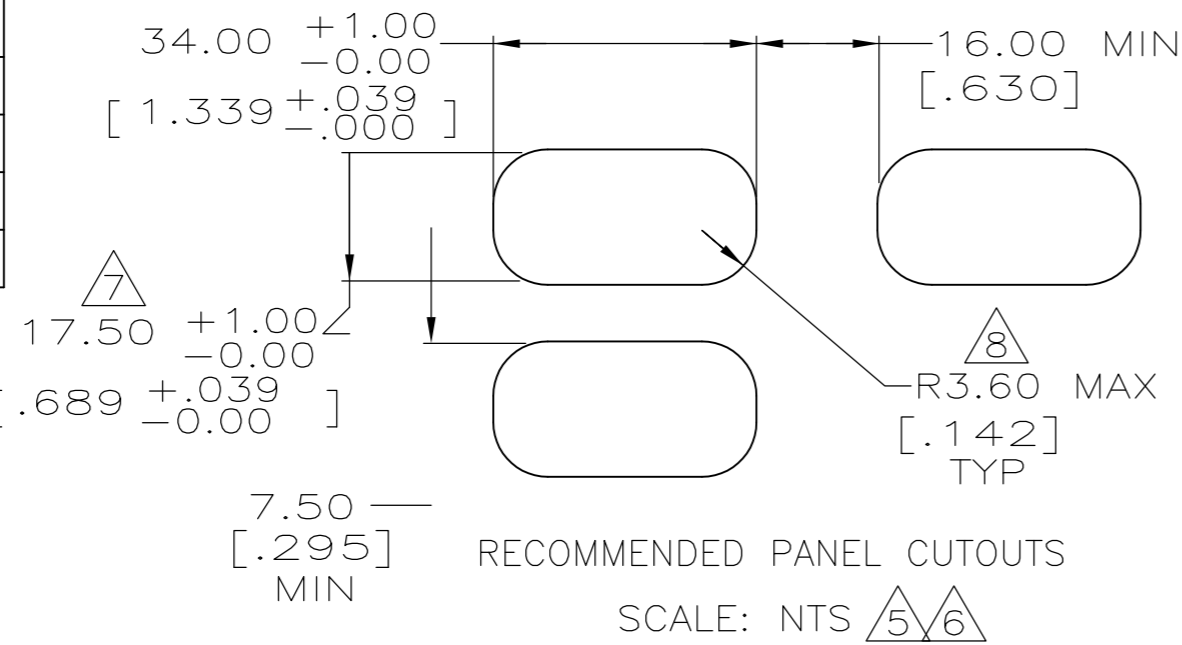

$\triangle 1$  HOUSING  
 AMP P/N 443163-1 (NATURAL)  
 AMP P/N 443163-2 (PALE BLUE)  
 QTY = 1

NATURAL	443160-2
PALE BLUE	443160-1
HOUSING COLOR	PART NUMBER

- $\triangle 1$  MAT'L: 4/6 NYLON UL94V-2 MLDG. CMPD. COLOR: SEE TABLE.
- $\triangle 2$  MAT'L: BRASS PER ASTM-B-16
- $\triangle 3$  MAT'L: STAINLESS STEEL PER QQ-S-766
- $\triangle 4$  FINISH: TIN PLATED PER MIL-T-10727
- $\triangle 5$  RECOMMENDED PANEL THICKNESS: 1.30-3.20 [ .051-.126 ].
- $\triangle 6$  RECOMMEND REMOVAL OF SHARP EDGE ON CONNECTOR INSERTION SIDE OF PANEL CUT OUT TO FACILITATE INSERTION OF HOUSING INTO PANEL.
- $\triangle 7$  TOLERANCE IS  $\begin{matrix} +0.20 \\ -0.00 \end{matrix}$  [ .008 ] FOR PANELS OVER 2.90 [ .114 ] THICK.
- $\triangle 8$  SQUARED CORNERS ARE ACCEPTABLE.
- $\triangle 9$  ANTI-VIBRATION TABS MAXIMUM FLEX WIDTH: 22.00 [ .866 ] WITH 3.20 [ .126 ] THICK PANEL.
- $\triangle 10$  DFE DETAIL SYMBOL (PA46), IS FOR RECYCLING IDENTIFICATION ONLY, NOT A PART NUMBER.

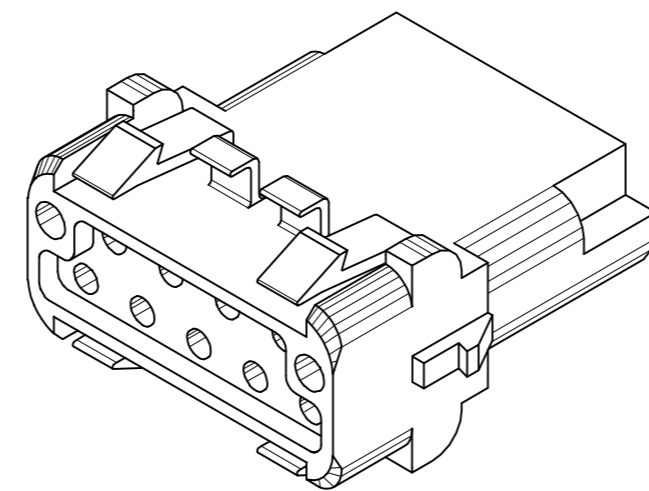

ISOMETRIC VIEW  
 SCALE: NTS

THIS DRAWING IS A CONTROLLED DOCUMENT.		DWN	C.C.THOMAS	7-27-95	Tyco Electronics Corporation Harrisburg, PA 17105-3608	
DIMENSIONS:		CHK	C.SHELLY	7-27-95		
mm		APVD	C.SHELLY	7-27-95		
TOLERANCES UNLESS OTHERWISE SPECIFIED:		PRODUCT SPEC				
0 PLC $\pm$ -		APPLICATION SPEC			NAME	KIT,RECEPTACLE,9 POSN.,LGH
1 PLC $\pm$ -					SIZE	A2
2 PLC $\pm$ 0.20[.008]					CAGE CODE	00779
3 PLC $\pm$ -					DRAWING NO	C=443160
4 PLC $\pm$ -					RESTRICTED TO	-
ANGLES $\pm$ -		WEIGHT	-		SCALE	NTS
MATERIAL		FINISH	SEE TABLE		SHEET	1 OF 1
SEE TABLE					REV	C
		CUSTOMER DRAWING				