



Chipsmall Limited consists of a professional team with an average of over 10 year of expertise in the distribution of electronic components. Based in Hongkong, we have already established firm and mutual-benefit business relationships with customers from,Europe,America and south Asia,supplying obsolete and hard-to-find components to meet their specific needs.

With the principle of “Quality Parts,Customers Priority,Honest Operation,and Considerate Service”,our business mainly focus on the distribution of electronic components. Line cards we deal with include Microchip,ALPS,ROHM,Xilinx,Pulse,ON,Everlight and Freescale. Main products comprise IC,Modules,Potentiometer,IC Socket,Relay,Connector.Our parts cover such applications as commercial,industrial, and automotives areas.

We are looking forward to setting up business relationship with you and hope to provide you with the best service and solution. Let us make a better world for our industry!



Contact us

Tel: +86-755-8981 8866 Fax: +86-755-8427 6832

Email & Skype: info@chipsmall.com Web: www.chipsmall.com

Address: A1208, Overseas Decoration Building, #122 Zhenhua RD., Futian, Shenzhen, China



REVISIONS				
P	LTR	DESCRIPTION	DATE	APPV
B	REV PER ECO	16-017468	1-12-16	CT EO

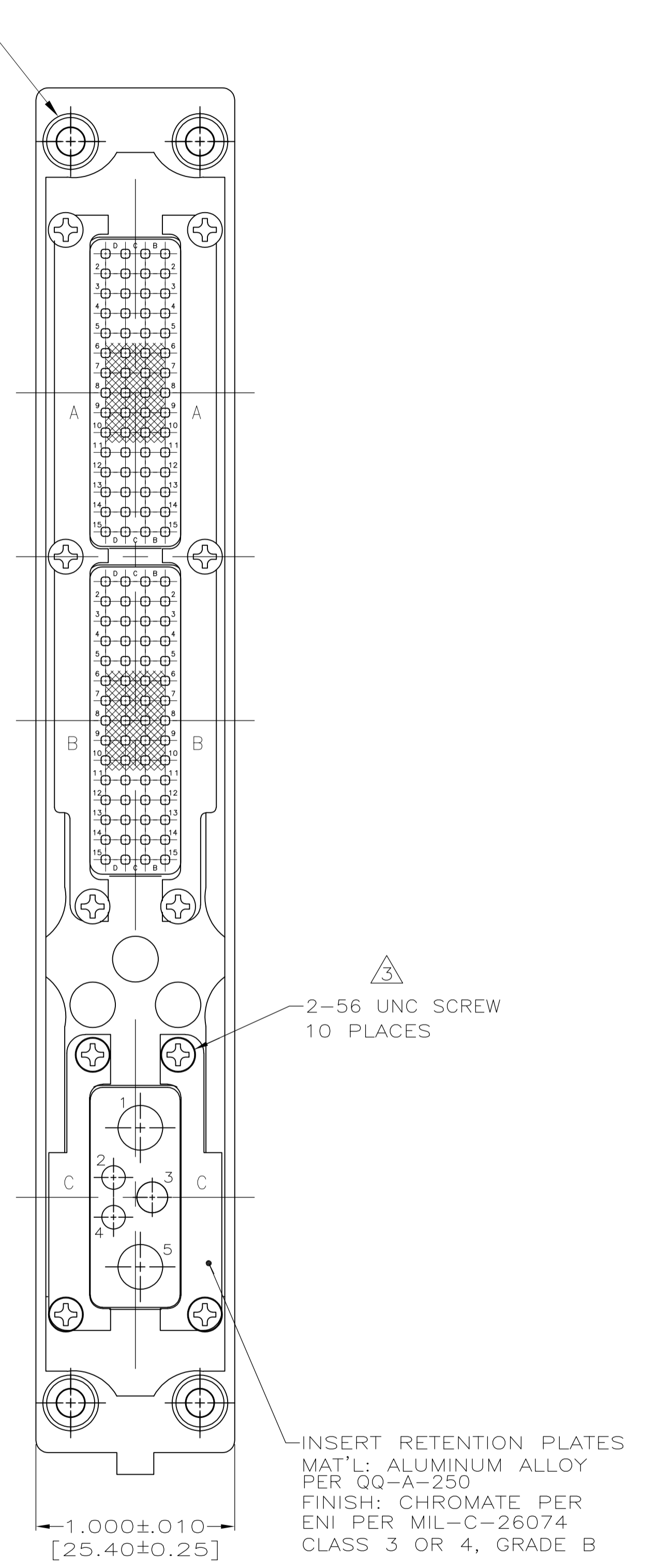
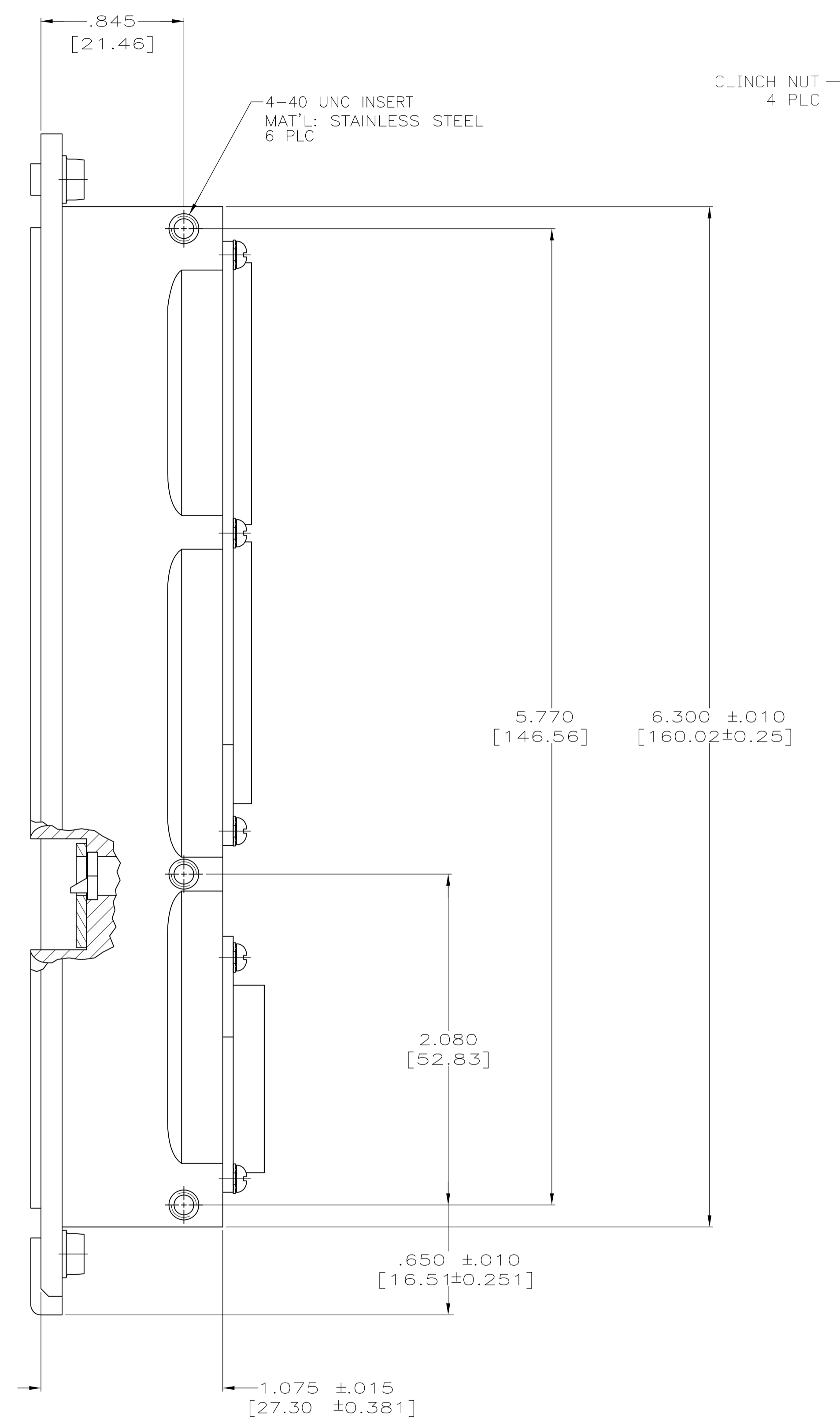
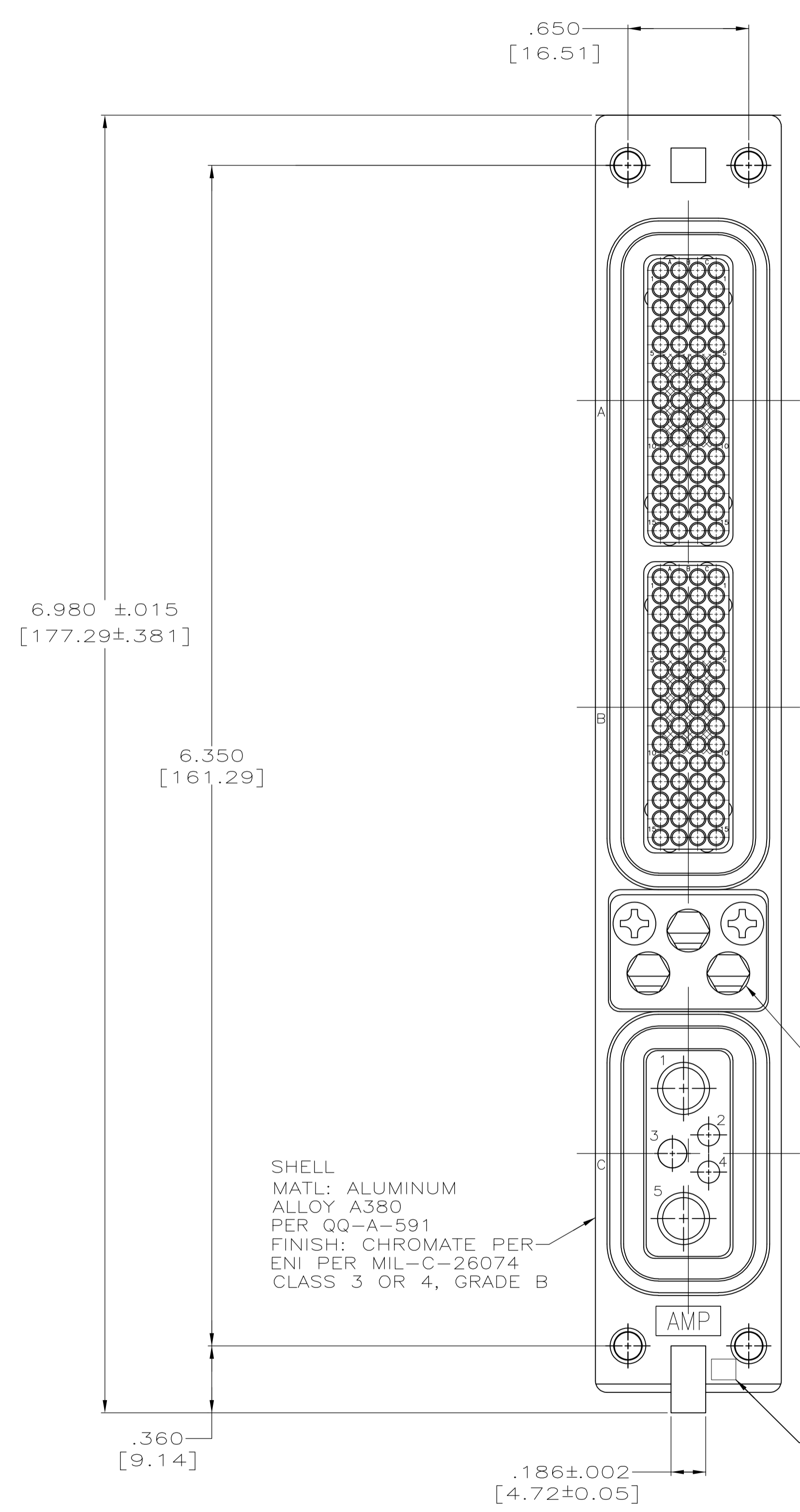

- PARTS MEET THE REQUIRMENTS OF THE ARINC 600 SPECIFICATION.
- NO CONTACTS ARE INCLUDED WITH THE CONNECTOR
- RETAINER PLATE SCREWS ARE PAN HEAD STYLE.
- KEYING HARDWARE SUPPLIED UNASSEMBLED.

NOTES	REAR RELEASE 13C2 PIN C MODULE	FRONT RELEASE 60 SOCKET B MODULE	FRONT RELEASE 60 SOCKET A MODULE	448705-1 PART NUMBER
THIS DRAWING IS A CONTROLLED DOCUMENT.	DIN N. FRITZ 12-3-92	FRONT RELEASE 60 SOCKET	FRONT RELEASE 60 SOCKET	448705-1
DIMENSIONS: INCHES	CHK S. WRIGHT 12-4-92	PRODUCT SPEC	APPLICATION SPEC	TE Connectivity
TOLERANCES UNLESS OTHERWISE SPECIFIED:	APVD	NAME	SIZE	RECEPTACLE ASSEMBLY, SIZE ONE ARINC 600, FRONT RELEASE
0 PLC ± -	APVD	PRODUCT SPEC	APPLICATION SPEC	RESTRICTED TO
1 PLC ± -	APVD	NAME	SIZE	00779
2 PLC ± -	APVD	PRODUCT SPEC	APPLICATION SPEC	448705
3 PLC ± .005 [0.13]	APVD	NAME	SIZE	CUSTOMER DRAWING
4 PLC ± -	APVD	PRODUCT SPEC	APPLICATION SPEC	SCALE 2:1 SHEET 1 OF 1 REV B
ANGLES ± -	APVD	NAME	SIZE	
MATERIAL SEE CALLOUT	FINISH SEE CALLOUT	WEIGHT 0.000000	A1 00779 C=448705	