



Chipsmall Limited consists of a professional team with an average of over 10 year of expertise in the distribution of electronic components. Based in Hongkong, we have already established firm and mutual-benefit business relationships with customers from,Europe,America and south Asia,supplying obsolete and hard-to-find components to meet their specific needs.

With the principle of “Quality Parts,Customers Priority,Honest Operation,and Considerate Service”,our business mainly focus on the distribution of electronic components. Line cards we deal with include Microchip,ALPS,ROHM,Xilinx,Pulse,ON,Everlight and Freescale. Main products comprise IC,Modules,Potentiometer,IC Socket,Relay,Connector.Our parts cover such applications as commercial,industrial, and automotives areas.

We are looking forward to setting up business relationship with you and hope to provide you with the best service and solution. Let us make a better world for our industry!



Contact us

Tel: +86-755-8981 8866 Fax: +86-755-8427 6832

Email & Skype: info@chipsmall.com Web: www.chipsmall.com

Address: A1208, Overseas Decoration Building, #122 Zhenhua RD., Futian, Shenzhen, China



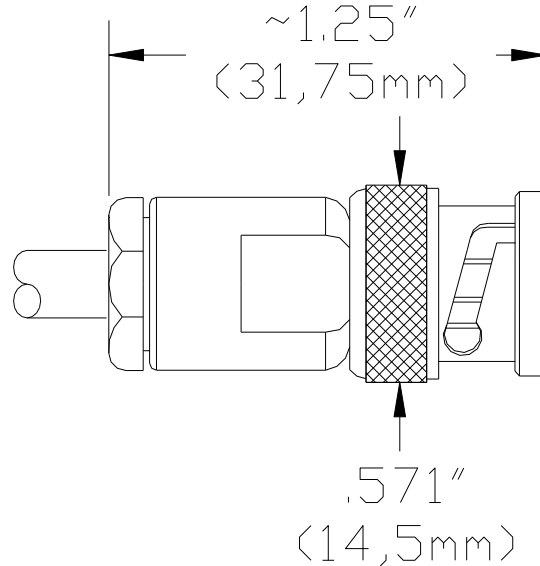

FEATURES:

- Do-it-yourself, field serviceable male BNC connector.
- Connector accepts cable types RG/U: 55, 55A, 55B, 58, 58C, 141, 141A, 142B, 223
- Meets interface requirements of MIL-STD-348

MATERIALS:

Body and Fittings – Tarnish Resistant Nickel Plated Brass
Outer Contact – Tarnish Resistant Nickel Plated Brass
Center Contact – Gold Plated Brass
Dielectric – PTFE
Gasket – Silicone Rubber

RATINGS:

Voltage: Hands free usage in controlled voltage environments: 500 Vrms Max. *For CE compliance:* not intended for hand-held use at voltages above 33 Vrms/70Vdc.

Nominal Impedance: 50 Ohms

ORDERING INFORMATION: Model 4488

All dimensions are in inches. Tolerances (except noted): .xx = ±.02" (.51 mm), .xxx = ±.005" (.127 mm).

All specifications are to the latest revisions. Specifications are subject to change without notice.

Registered trademarks are the property of their respective companies.

Sales: 800-490-2361 Fax: 888-403-3360 Technical Support: 800-241-2060 (technicalsupport@pomonatest.com)
For "Where to Buy" information, visit the Pomona web site at www.pomonaelectronics.com

Style A

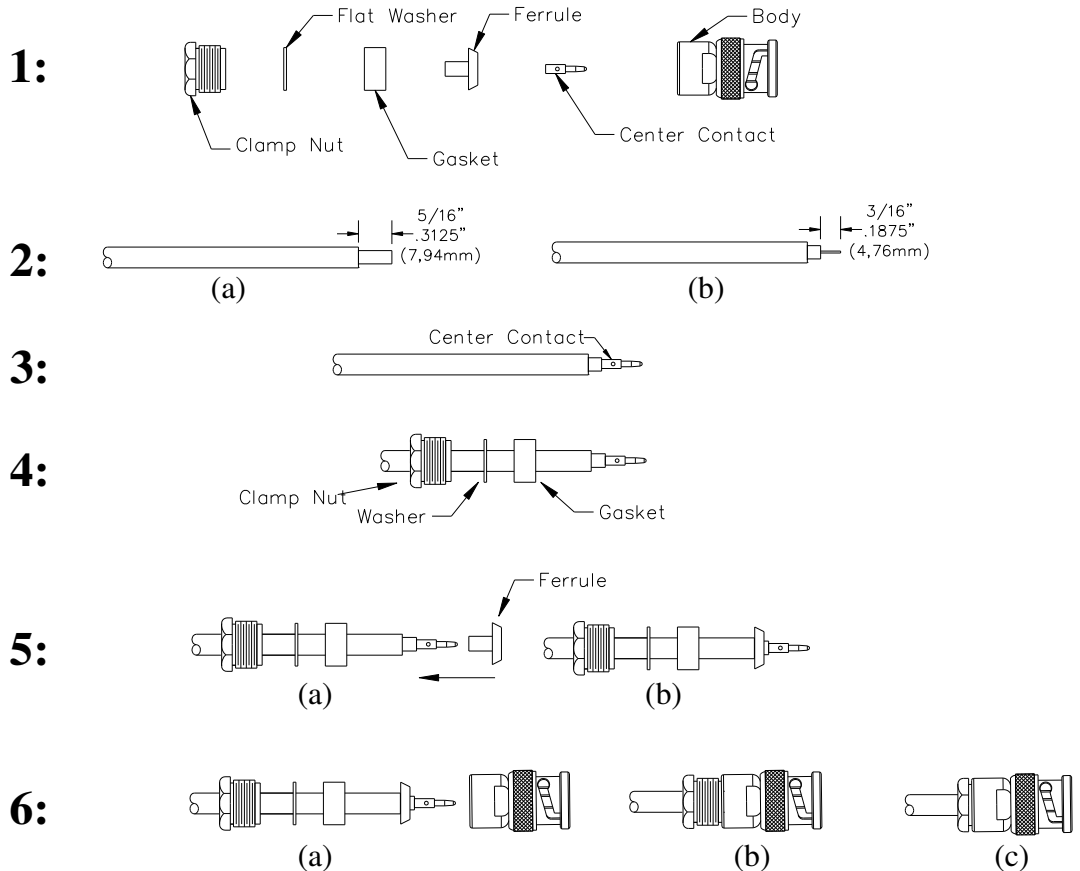

Assembly Instructions

1. Verify all parts are present.
2. (a) Cut outer jacket and shield $5/16''$ (7,94mm) from cable end to the depth of the dielectric. Remove outer insulation and coax shield. (b) Cut $3/16''$ (4,76mm) from the cable end to the depth of the center conductor and remove dielectric exposing center conductor.
3. Slide center pin contact onto center conductor, all the way against the dielectric. Solder or crimp to center contact.
4. Slide clamp nut, washer and gasket on to coax cable.
5. (a) Slide ferrule over dielectric and under the coax braided shield. (b) Verify that ferrule is pushed up against outer jacket .
6. (a) Push assembly into body until center contact “snaps” into body. (b) Slide clamp nut, washer, gasket forward. (c) Use $7/16''$ (11mm) wrench on the body and clamp nut, tighten to 18 – 22 in-lbs.

Registered trademarks are the property of their respective companies.

Sales: 800-490-2361 Fax: 888-403-3360 Technical Support: 800-241-2060 (technicalsupport@pomonatest.com)
For “Where to Buy” information, visit the Pomona web site at www.pomonaelectronics.com

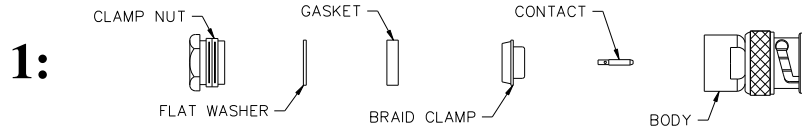

Style B

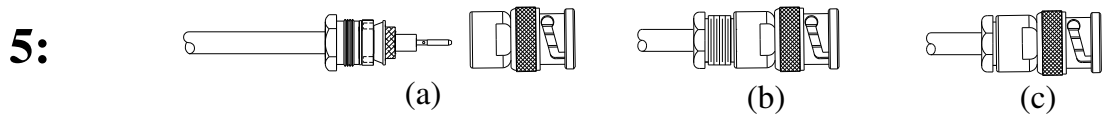
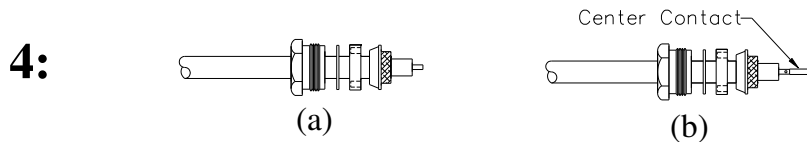
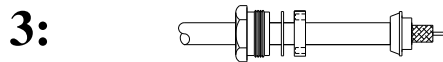
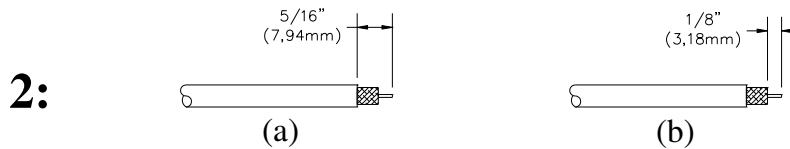

Assembly Instructions

1. Verify all parts are present.
2. (a) Cut outer jacket to the depth of the shield 5/16" (7,94mm) from cable end. Remove outer jacket.
(b) Cut shield and dielectric to the depth of the center connector 1/8" (3,18 mm) from cable end. Remove shield and dielectric exposing center conductor.
3. Slide clamp nut, washer, gasket and braid clamp onto coax cable.
4. (a) Comb braid out and fold braid back over braid clamp. Trim braid even with braid clamp. (b) Slide center pin contact onto center conductor, all the way against the dielectric. Solder or crimp to center contact.
5. (a) Slide clamp nut, flat washer and gasket forward against braid clamp. (b) Push assembly into body.
(c) Use 7/16" (11mm) wrench on the body and clamp nut, tighten to 35 – 40 in-lbs.

All dimensions are in inches. Tolerances (except noted): .xx = ±.02" (.51 mm), .xxx = ±.005" (.127 mm).

All specifications are to the latest revisions. Specifications are subject to change without notice.

Registered trademarks are the property of their respective companies.

Sales: 800-490-2361 Fax: 888-403-3360 Technical Support: 800-241-2060 (technicalsupport@pomonatest.com)
For "Where to Buy" information, visit the Pomona web site at www.pomonaelectronics.com