



Chipsmall Limited consists of a professional team with an average of over 10 year of expertise in the distribution of electronic components. Based in Hongkong, we have already established firm and mutual-benefit business relationships with customers from,Europe,America and south Asia,supplying obsolete and hard-to-find components to meet their specific needs.

With the principle of “Quality Parts,Customers Priority,Honest Operation,and Considerate Service”,our business mainly focus on the distribution of electronic components. Line cards we deal with include Microchip,ALPS,ROHM,Xilinx,Pulse,ON,Everlight and Freescale. Main products comprise IC,Modules,Potentiometer,IC Socket,Relay,Connector.Our parts cover such applications as commercial,industrial, and automotives areas.

We are looking forward to setting up business relationship with you and hope to provide you with the best service and solution. Let us make a better world for our industry!



Contact us

Tel: +86-755-8981 8866 Fax: +86-755-8427 6832

Email & Skype: info@chipsmall.com Web: www.chipsmall.com

Address: A1208, Overseas Decoration Building, #122 Zhenhua RD., Futian, Shenzhen, China



Integrated Transceiver Modules for ZigBee / 802.15.4 (2.4 GHz) Development Kit Available

FEATURES

- 100mW output power
- Long range: 4000 feet
- Miniature footprint: 0.9" x 1.63"
- Integrated PCB F antenna or U.FL connector for external antenna
- Worldwide acceptance: FCC, IC and CE
- Powerful Texas Instruments 256k MSP430 with 802.15.4 MAC or ZigBee Stack
- LSR serial interface based on 802.15.4 MAC
- Low power operation
- RoHS compliant
- Streamlined development with LSR design services.
- License options available to purchase design or integrate design.

APPLICATIONS

- Security
- Lighting Control
- HVAC Control
- Sensor Networks
- Medical
- Smart Energy

DESCRIPTION

The ProFLEX01 module is a high performance 2.4GHz IEEE 802.15.4 radio (CC2520 & CC2591) and microcontroller (MSP430F5437) in a cost effective, pre-certified footprint.



The module comes preloaded with the TI MAC-Stack that can be used with the LSR host serial interface.

Full debug and programming capabilities are included to develop custom applications. Easily load the TI ZigBee stack or MAC onto the module and create your own network.

Need to get to market quickly? Not an expert in 802.15.4 or ZigBee? Need a custom antenna? Would you like to own the design? Would you like a custom design? Not quite sure what you need? Do you need help with your host board? LS Research Design Services will be happy to develop custom hardware or software, integrate the design, or license the design so you can manufacture yourself. Contact us at sales@lsr.com or call us at 262-375-4400.



ORDERING INFORMATION

Order Number	Description
LS240-ZP-01-A10	This number has been replaced with 450-0011
LS240-ZP-01-A20	This number has been replaced with 450-0012
LSDEV-ZP01-A10	This number has been replaced with 450-0023
450-0011	ProFLEX01 Module with PCB F antenna
450-0012	ProFLEX01 Module with U.FL connector for external antenna
450-0023	ProFLEX01 Development Kit

Table 1 Orderable ProFLEX01 Model Numbers

The information in this document is subject to change without notice.

MODULE ACCESSORIES

	Order Number	Description
	<p>001-0001</p>	<p>2.4 GHz Dipole Antenna with Reverse Polarity SMA Connector</p>
	<p>080-0001</p>	<p>U.FL to Reverse Polarity SMA Bulkhead Cable 105mm</p>

BLOCK DIAGRAM

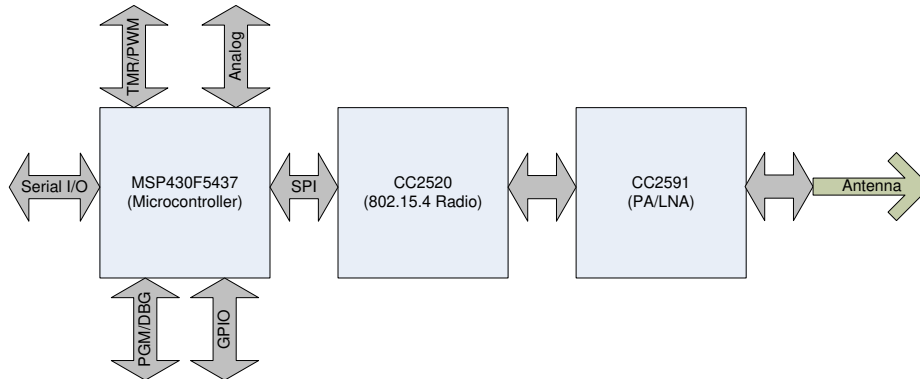

Figure 1 ProFLEX01 Module Block Diagram – High-Level

DEVELOPMENT KIT

The ProFLEX01 Development Kit can be used out of the box to evaluate RF range performance with the simple press of a button.

Users interested in further investigating the performance and capabilities of the ProFLEX01 Module can use the ProFLEX01 Test Tool. This PC-based software can demonstrate just how easy it is to send & receive data, collect performance data, change channels, power levels, or addresses using the LSR Serial Host Protocol with another microcontroller.

More advanced users can use the development board to create and debug their own software for the ProFLEX01 module using the 802.15.4 MAC or ZigBee stack from TI.

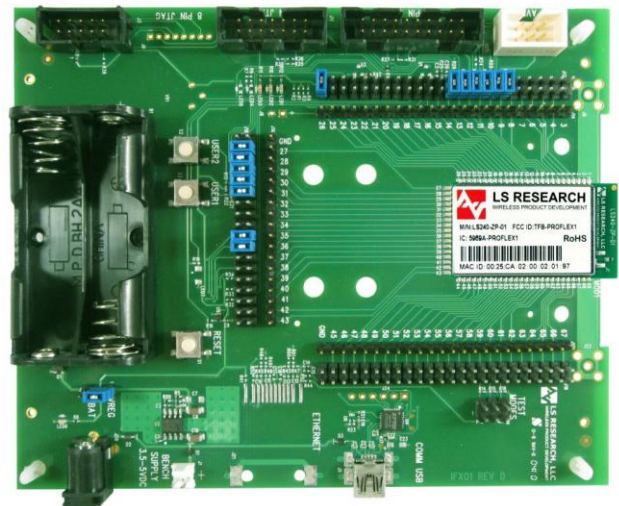

Figure 2 ProFLEX01 Development Board

Part Number	Description
450-0023	ProFLEX01 Development Kit with F-Antenna

Kit Contents

- ProFLEX01 Development Board with ProFLEX01 Series Transceiver Module with F antenna (x2)
- USB Cable (x2)
- AA Batteries (x4)
- Software & Technical Information CD
- Quick Start Guide

TABLE OF CONTENTS

FEATURES	1
APPLICATIONS.....	1
DESCRIPTION	1
ORDERING INFORMATION	1
MODULE ACCESSORIES	2
BLOCK DIAGRAM.....	3
DEVELOPMENT KIT.....	3
Kit Contents	3
MODULE PINOUT AND PIN DESCRIPTIONS	6
MODULE OVERVIEW.....	11
Microcontroller	11
Radio	12
PA/LNA	14
Antenna Options	14
MODES OF OPERATION	16
Host Microcontroller	16
Software Stacks	17
DEVELOPMENT TOOLS	18
TI MSP-FET430UIF	18
IAR Embedded Workbench for MSP430	18
ELECTRICAL SPECIFICATIONS	19
Absolute Maximum Ratings	19
Recommended Operating Conditions	19
General Characteristics	20
RF Characteristics	21
SOLDERING RECOMMENDATIONS.....	24
Recommended Reflow Profile for Lead Free Solder	24
CLEANING.....	25
OPTICAL INSPECTION	25

The information in this document is subject to change without notice.

REWORK	25
SHIPPING, HANDLING, AND STORAGE	25
Shipping	25
Handling	25
Moisture Sensitivity Level (MSL).....	25
Storage	25
Repeating Reflow Soldering	25
AGENCY STATEMENTS	26
Agency Certifications	26
Federal Communication Commission Interference Statement	26
Industry Canada Statements.....	27
OEM Responsibilities to comply with FCC and Industry Canada Regulations	28
End Product Labeling	29
EUROPE	30
CE Notice	30
Declaration of Conformity (DOC)	30
MECHANICAL DATA.....	31
PCB Footprint.....	31
General Module Dimensions.....	32
COMPATIBILITY.....	33
MODULE REVISION HISTORY	34
Rev B	34
Rev C	34
CONTACTING LS RESEARCH	35

MODULE PINOUT AND PIN DESCRIPTIONS

MCU#	GND	1	Texas Instruments MSP430F5437																69	GND	MCU#
-	GND	2																	68	GND	-
-	GND	3																	67	GND	-
-	NC	4																	66	NC	-
-	NC	5																	65	NC	-
-	NC	6																	64	NC	-
-	NC	7																	63	NC	-
-	NC	8																	62	NC	-
74	JTAG TMS	9																	61	P5.6	56
73	JTAG TDI	10																	60	P5.7	57
75	JTAG TCK	11																	59	P3.6	41
72	JTAG TDO	12																	58	P5.5	55
71	TEST	13																	57	P3.7	42
76	nRESET	14																	56	P5.4	54
9	P5.0	15																	55	P2.4	29
10	P5.1	16																	54	P2.3	28
77	P6.0	17																	53	P2.2	27
78	P6.1	18																	52	P2.1	26
79	P6.2	19																	51	P2.0	25
80	P6.3	20																	50	P1.1	18
1	P6.4	21																	49	P1.0	17
2	P6.5	22																	48	P7.7	8
3	P6.6	23																	47	P1.2	19
4	P6.7	24																	46	P8.0	60
5	P7.4	25																	45	P8.1	61
-	VCC - 3V3DC	26																	44	GND	-
		27	28	29	30	31	32	33	34	35	36	37	38	39	40	41	42	43			
		P4.7	P4.6	P4.5	P4.4	P4.3	P4.2	P4.1	P4.0	P3.4/UART TX	P3.5/UART RX	P7.2	P7.3	P8.6	P8.5	P8.4	P8.3	P8.2			
MCU#		53	52	48	47	46	45	44	43	39	40	58	59	66	65	64	63	62	MCU#		

Figure 3 Module Pinout

Module Pin	Name	MCU Pin	Type	Description
1	GND	N/A	GND	Ground
2	GND	N/A	GND	Ground
3	GND	N/A	GND	Ground
4	NC	N/A	NC	No Connect
5	NC	N/A	NC	No Connect
6	NC	N/A	NC	No Connect
7	NC	N/A	NC	No Connect
8	NC	N/A	NC	No Connect
9	JTAG TMS	74	I/O	General-purpose digital I/O Test mode select
10	JTAG TDI	73	I/O	General-purpose digital I/O Test data input or test clock input
11	JTAG TCK	75	I/O	General-purpose digital I/O Test clock
12	JTAG TDO	72	I/O	General-purpose digital I/O Test data output port
13	TEST	71	I	Test mode pin – select digital I/O on JTAG pins Spy-bi-wire input clock
14	nRESET	76	I/O	Reset input active low Non-maskable interrupt input Spy-bi-wire data input/output
15	P5.0	9	I/O	General-purpose digital I/O Output of reference voltage to the ADC Input for an external reference voltage to the ADC
16	P5.1	10	I/O	General-purpose digital I/O Negative terminal for the ADC's reference voltage for both sources, the internal reference voltage, or an external applied reference voltage
17	P6.0	77	I/O	General-purpose digital I/O Analog input
18	P6.1	78	I/O	General-purpose digital I/O Analog input
19	P6.2	79	I/O	General-purpose digital I/O Analog input
20	P6.3	80	I/O	General-purpose digital I/O Analog input
21	P6.4	1	I/O	General-purpose digital I/O Analog input
22	P6.5	2	I/O	General-purpose digital I/O Analog input

The information in this document is subject to change without notice.

Module Pin	Name	MCU Pin	Type	Description
23	P6.6	3	I/O	General-purpose digital I/O Analog input
24	P6.7	4	I/O	General-purpose digital I/O Analog input
25	P7.4	5	I/O	General-purpose digital I/O Analog input
26	VCC - 3V3DC	VCC	VCC	Supply Voltage
27	P4.7	53	I/O	General-purpose digital I/O Timer_B7 clock input SMCLK output
28	P4.6	52	I/O	General-purpose digital I/O Timer_B7 capture CCR6: CCI6A/CCI6B input, compare: Out6 output
29	P4.5	48	I/O	General-purpose digital I/O Timer_B7 capture CCR5: CCI5A/CCI5B input, compare: Out5 output
30	P4.4	47	I/O	General-purpose digital I/O Timer_B7 capture CCR4: CCI4A/CCI4B input, compare: Out4 output
31	P4.3	46	I/O	General-purpose digital I/O Timer_B7 capture CCR3: CCI3A/CCI3B input, compare: Out3 output
32	P4.2	45	I/O	General-purpose digital I/O Timer_B7 capture CCR2: CCI2A/CCI2B input, compare: Out2 output
33	P4.1	44	I/O	General-purpose digital I/O Timer_B7 capture CCR1: CCI1A/CCI1B input, compare: Out1 output
34	P4.0	43	I/O	General-purpose digital I/O Timer_B7 capture CCR0: CCI0A/CCI0B input, compare: Out0 output
35	P3.4/UART TX	39	I/O	General-purpose digital I/O Transmit data – USCI_A0 UART mode Slave in, master out – USCI_A0 SPI mode
36	P3.5/UART RX	40	I/O	General-purpose digital I/O Receive data – USCI_A0 UART mode Slave out, master in – USCI_A0 SPI mode
37	P7.2	58	I/O	General-purpose digital I/O Switch all PWM outputs high impedance – Timer_B SVM output
38	P7.3	59	I/O	General-purpose digital I/O Timer1_A3 CCR2 capture: CCI2B input, compare: Out2 output

The information in this document is subject to change without notice.

Module Pin	Name	MCU Pin	Type	Description
39	P8.6	66	I/O	General-purpose digital I/O Timer1_A3 CCR1 capture: CCI1B input, compare: Out1 output
40	P8.5	65	I/O	General-purpose digital I/O Timer1_A3 CCR0 capture: CCI0B input, compare: Out0 output
41	P8.4	64	I/O	General-purpose digital I/O Timer0_A5 CCR4 capture: CCI4B input, compare: Out4 output
42	P8.3	63	I/O	General-purpose digital I/O Timer0_A5 CCR3 capture: CCI3B input, compare: Out3 output
43	P8.2	62	I/O	General-purpose digital I/O Timer0_A5 CCR2 capture: CCI2B input, compare: Out2 output
44	GND	N/A	GND	Ground
45	P8.1	61	I/O	General-purpose digital I/O Timer0_A5 CCR1 capture: CCI1B input, compare: Out1 output
46	P8.0	60	I/O	General-purpose digital I/O Timer0_A5 CCR0 capture: CCI0B input, compare: Out0 output
47	P1.2	19	I/O	General-purpose digital I/O with port interrupt TA0 CCR1 capture: CCI1A input, compare: Out1 output BSL receive input
48	P7.7	8	I/O	General-purpose digital I/O Analog input
49	P1.0	17	I/O	General-purpose digital I/O with port interrupt Timer0_A5 clock signal TACLK input ACLK output
50	P1.1	18	I/O	General-purpose digital I/O with port interrupt Timer0_A5 CCR0 capture: CCI0A input, compare: Out0 output BSL transmit output
51	P2.0	25	I/O	General-purpose digital I/O with port interrupt Timer1_A3 clock signal TA1CLK input MCLK output
52	P2.1	26	I/O	General-purpose digital I/O with port interrupt Timer1_A3 CCR0 capture: CCI0A input, compare: Out0 output
53	P2.2	27	I/O	General-purpose digital I/O with port interrupt Timer1_A3 CCR1 capture: CCI1A input, compare: Out1 output

The information in this document is subject to change without notice.

Module Pin	Name	MCU Pin	Type	Description
54	P2.3	28	I/O	General-purpose digital I/O with port interrupt Timer1_A3 CCR2 capture: CCI2A input, compare: Out2 output
55	P2.4	29	I/O	General-purpose digital I/O with port interrupt RTCCLK output
56	P5.4	54	I/O	General-purpose digital I/O Slave out, master in – USCI_B1 SPI mode I2C clock – USCI_B1 I2C mode
57	P3.7	42	I/O	General-purpose digital I/O Slave in, master out – USCI_B1 SPI mode I2C data – USCI_B1 I2C mode
58	P5.5	55	I/O	General-purpose digital I/O Clock signal input – USCI_B1 SPI slave mode Clock signal output – USCI_B1 SPI master mode Slave transmit enable – USCI_A1 SPI mode
59	P3.6	41	I/O	General-purpose digital I/O Slave transmit enable – USCI_B1 SPI mode Clock signal input – USCI_A1 SPI slave mode Clock signal output – USCI_A1 SPI master mode
60	P5.7	57	I/O	General-purpose digital I/O Receive data – USCI_A1 UART mode Slave out, master in – USCI_A1 SPI mode
61	P5.6	56	I/O	General-purpose digital I/O Transmit data – USCI_A1 UART mode Slave in, master out – USCI_A1 SPI mode
62	NC	N/A	NC	No Connect
63	NC	N/A	NC	No Connect
64	NC	N/A	NC	No Connect
65	NC	N/A	NC	No Connect
66	NC	N/A	NC	No Connect
67	GND	N/A	GND	Ground
68	GND	N/A	GND	Ground
69	GND	N/A	GND	Ground

Table 2 ProFLEX01 Module Pin Descriptions

MODULE OVERVIEW

Figure 4 shows the internal interconnects of the ICs on the ProFLEX01 module. Consult the respective IC datasheets for details, or contact LSR sales to purchase the ProFLEX01 module schematics as part of LSR’s ModFLEX™ design program. For a high-level block diagram of the ProFLEX01 module, see Figure 1.

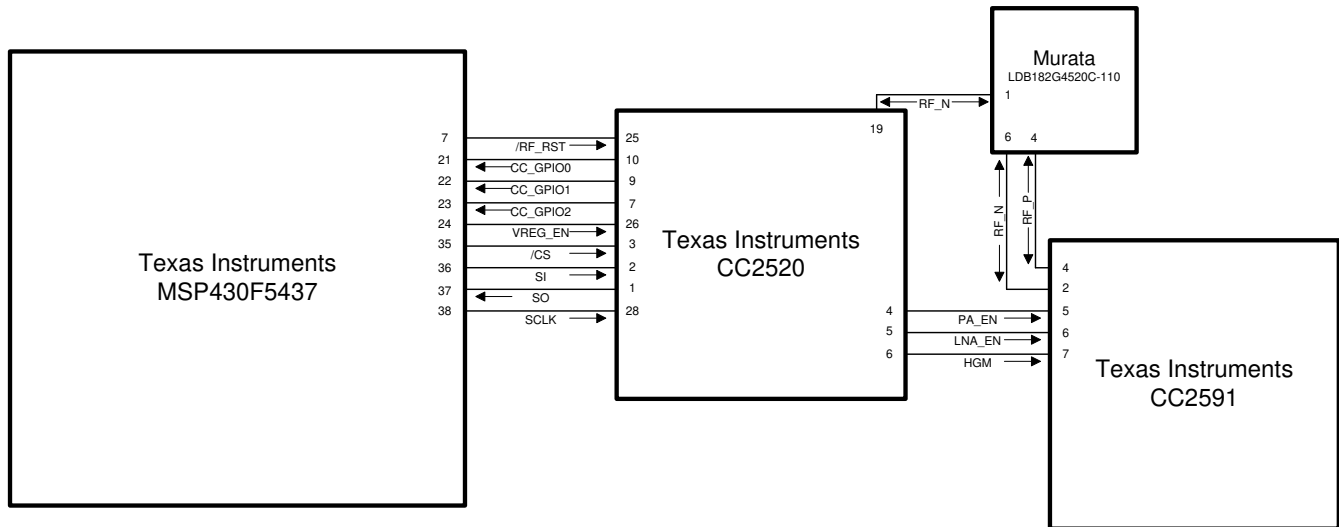

Figure 4 ProFLEX01 Module Block Diagram – Internal Interconnects

Microcontroller

A member of the Texas Instruments MSP430 family of ultra-low-power microcontrollers, the architecture, combined with five low-power modes, is optimized to achieve extended battery life. The device features a powerful 16-bit RISC CPU, 16-bit registers, and constant generators that contribute to maximum code efficiency. The digitally controlled oscillator (DCO) allows wake-up from low-power modes to active mode in less than 5 μs. It can be configured to use up to three 16-bit timers, a high performance 12-bit analog-to-digital (A/D) converter, up to four universal serial communication interfaces (USCI), hardware multiplier, DMA, real time clock module with alarm capabilities, and up to 87 I/O pins. Figure 5 shows a block diagram of the MSP430F5437.

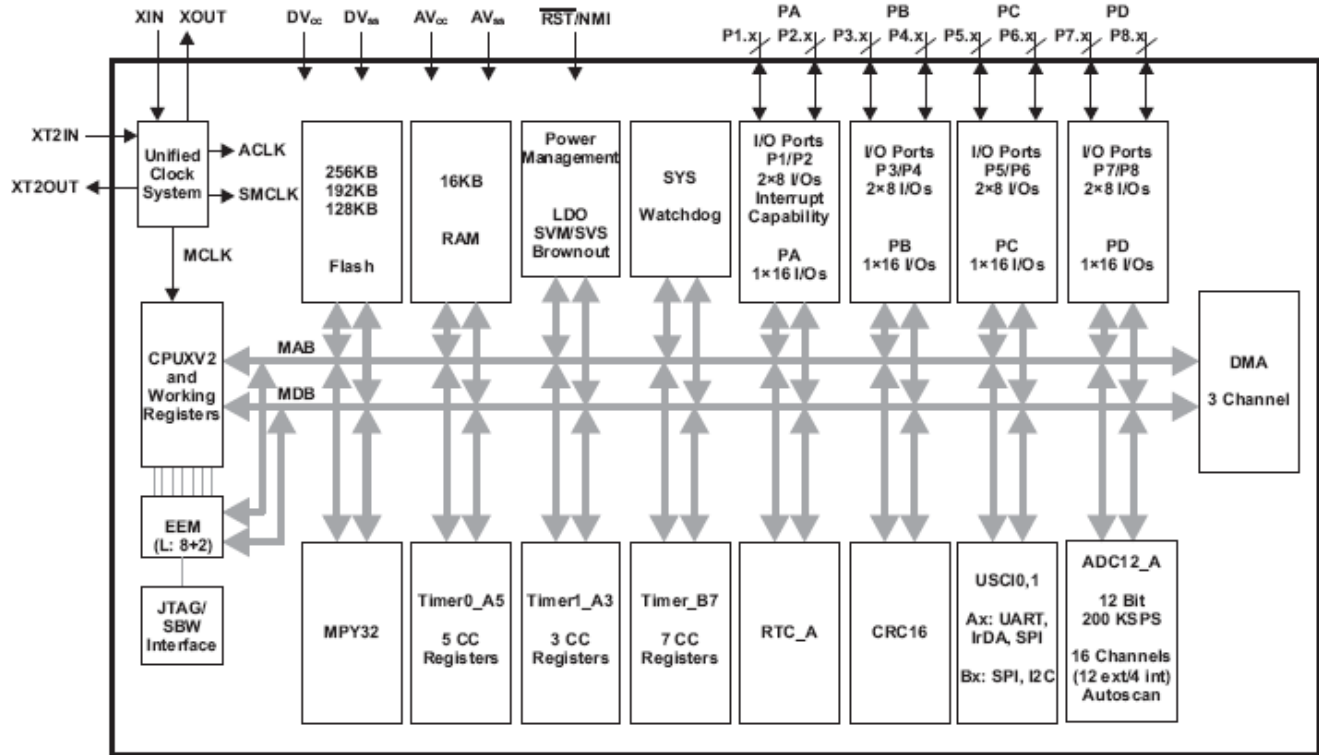

Figure 5 MSP430F5437 Block Diagram

Radio

The CC2520 is TI's second generation ZigBee / IEEE 802.15.4 RF transceiver for the 2.4 GHz unlicensed ISM band. This chip enables industrial grade applications by offering state-of-the-art selectivity/co-existence, excellent link budget, operation up to 125°C and low voltage operation. In addition, the C2520 provides extensive hardware support for frame handling, data buffering, burst transmissions, data encryption, data authentication, clear channel assessment, link quality indication and frame timing information. These features reduce the load on the host controller. Figure 6 shows a block diagram of the CC2520.

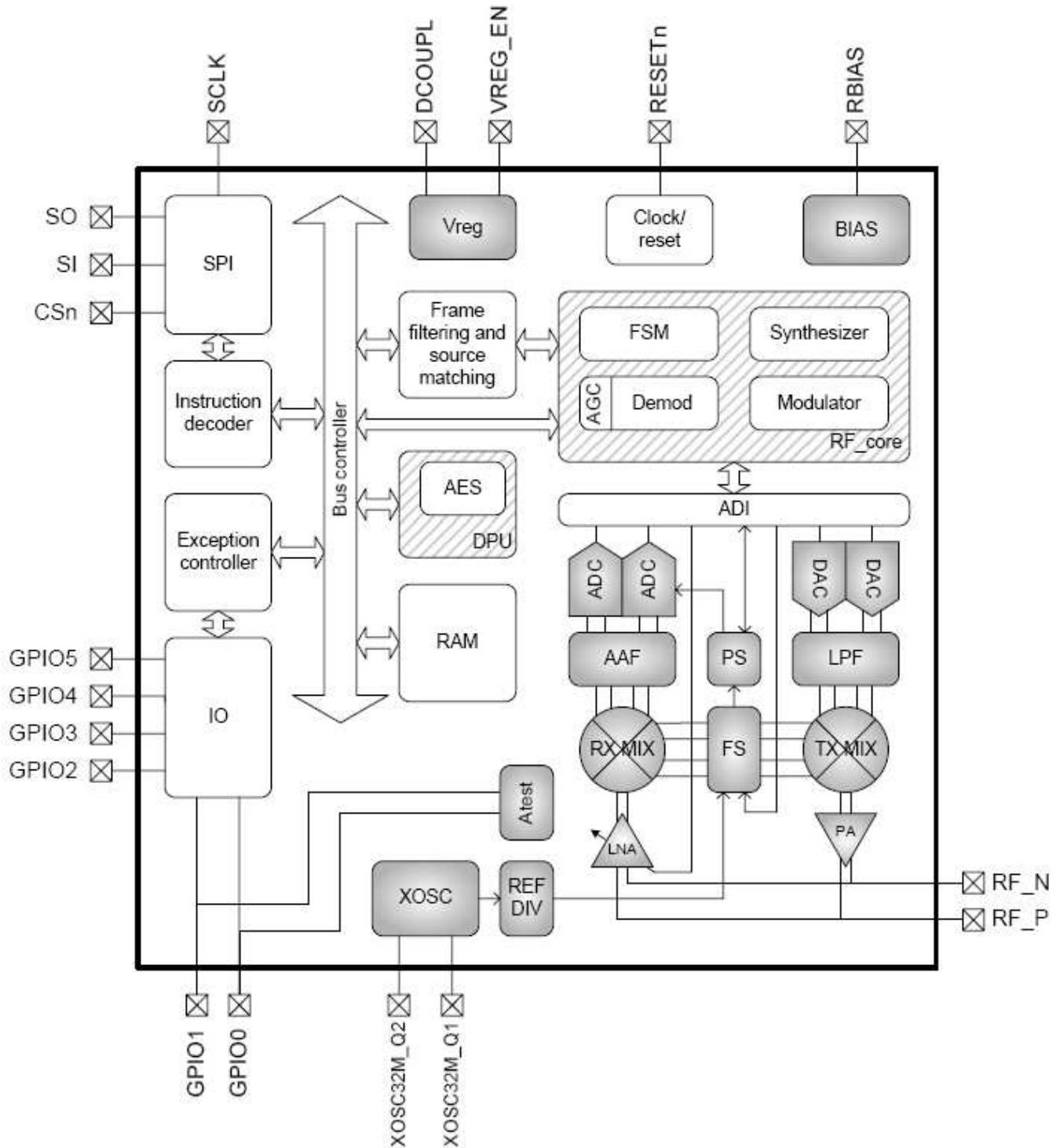

Figure 6 CC2520 Block Diagram

PA/LNA

The CC2591 is a cost-effective and high performance RF Front End for low-power and low-voltage 2.4-GHz wireless applications. It is a range extender for all existing and future 2.4-GHz low-power RF transceivers, transmitters and System-on-Chip products from Texas Instruments. It increases the link budget by providing a power amplifier for increased output power, and a LNA with low noise figure for improved receiver sensitivity. It provides a small size, high output power RF design with its 4x4-mm QFN-16 package. It contains PA, LNA, switches, RF-matching, and balun for simple design of high performance wireless applications. Figure 7 shows a block diagram of the CC2591.

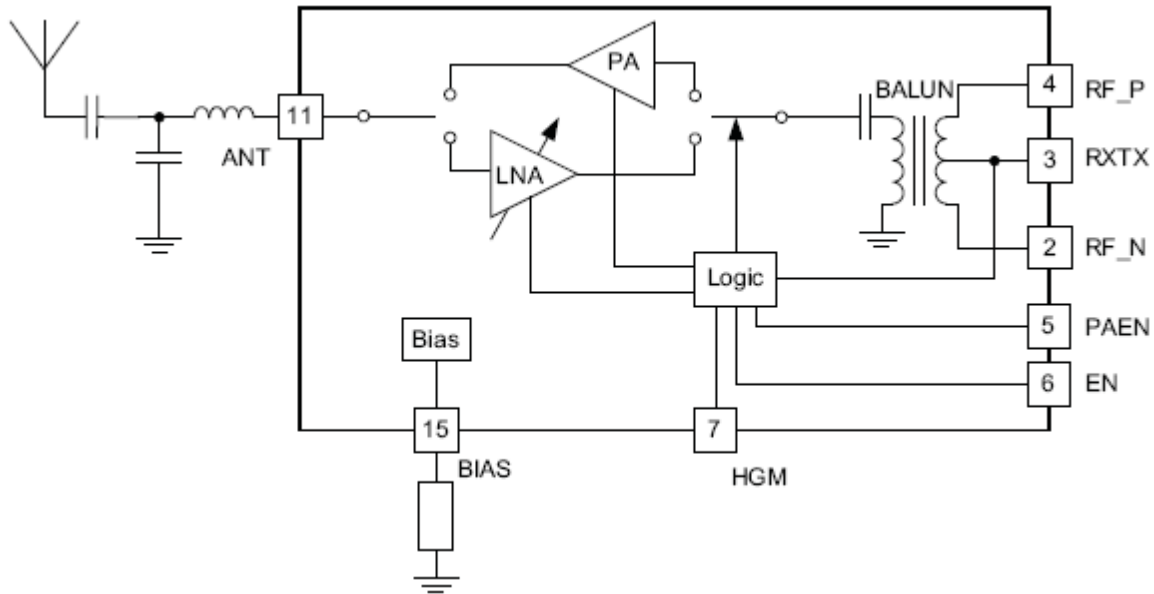

Figure 7 CC2591 Block Diagram

Antenna Options

The ProFLEX01 module includes an integrated PCB F-antenna. An optional configuration with a U.FL connector is also available. The module regulatory certification has been completed with the following antennas:

- PCB trace antenna
- LSR 001-0001 2.4 GHz Dipole Antenna with Reverse Polarity SMA Connector and LSR 080-0001 U.FL to Reverse Polarity SMA Bulkhead Cable 105mm
- Nearson S131CL-6-PX-2450S dipole antenna on a 6 inch cable with connectors.

An adequate ground plane is necessary to provide good efficiency. The ground plane of the host board on which the module is mounted increases the effective antenna ground plane size and improves the antenna performance.

The environment the module is placed in will dictate the range performance. The non-ideal characteristics of the environment will result in the transmitted signal being reflected, diffracted, and scattered. All of these factors randomly combine to create extremely complex scenarios that will affect the link range in various ways.

It is also best to keep some clearance between the antenna and nearby objects. This includes how the module is mounted in the product enclosure. Unless the items on the following list of recommendations are met, the radiation pattern can be heavily distorted.

Whichever antennas are used, it is best to keep a few things in mind when determining their location.

- Never place ground plane or copper trace routing underneath the antenna.
- LSR recommends keeping metal objects as far away from the antenna as possible. At a very minimum keep the antennas at least 16mm from any metallic objects, components, or wiring. The farther the antenna is placed from these interferers, the less the radiation pattern and gain will be perturbed
- Do not embed the antenna in a metallic or metalized plastic enclosure.
- Try to keep any plastic enclosure greater than 1 cm from the antenna in any orientation.

MODES OF OPERATION

- With a host microcontroller
- With the TI 802.15.4 MAC
- With the TI ZigBee stack

Host Microcontroller

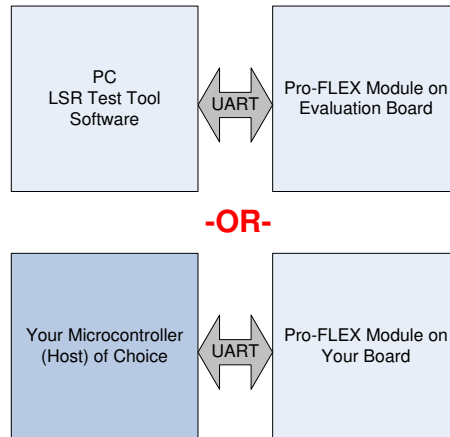

Figure 8 Host Microcontroller Modes of Operation

Out of the box the ProFLEX01 module contains an 802.15.4 based application that uses a host serial processor. This allows features of the module to be explored with the LSR PC based test tool, or controlled with a host microcontroller. The advantage of this method is simplicity; all major features of using the radio are simplified into a simple serial message, taking the burden of becoming a radio expert off the developer.

Use the Communications Log in the ModFLEX™ Test Tool software and serial host protocol documents to see the messages in action. It will help you become familiar with the serial commands and how to implement them on your own microcontroller.

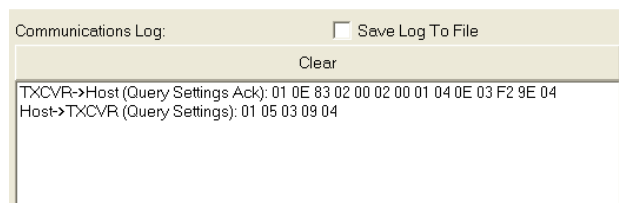

Figure 9 ModFLEX™ Test Tool Communications Log

Some examples of serial commands that can be used with the ProFLEX01 Module:

- Set/Query RF channel
- Set/Query RF power
- Set/Query device address
- Transmit RF data or notification RF data received
- Go to Sleep

Software Stacks

There are two software stacks provided by TI to streamline development:

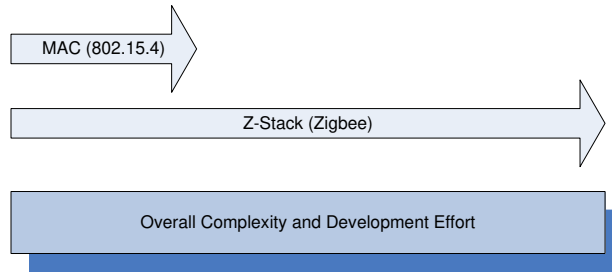

Figure 10 ProFLEX01 Compatible Stacks

802.15.4 MAC

- Use for applications requiring point-to-point or star network topology.
- Advantages: Quick learning curve, minimize software development, easy to deploy in the field
- Disadvantages: No mesh networking

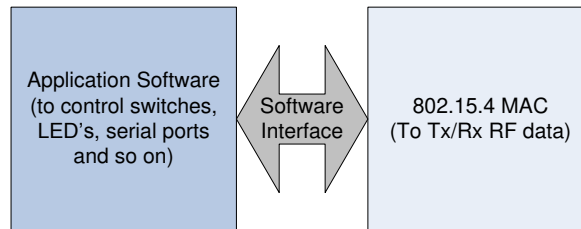

Figure 11 ProFLEX01 with 802.15.4 MAC

TI Z-Stack (ZigBee)

- Use when mesh networking is required.
- Advantages: Covers a large area with a ZigBee network.
- Disadvantages: Large learning curve, more software development, and complexity

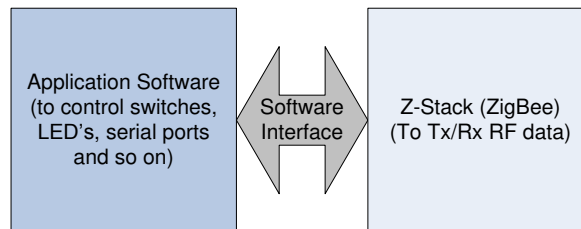

Figure 12 ProFLEX01 with TI Z-Stack (ZigBee)

DEVELOPMENT TOOLS

TI MSP-FET430UIF

Custom firmware development can be done on the ProFLEX01 module using development tools available through TI. Shown in Figure 13, a MSP-FETUIF USB interface is required. It plugs directly into the ProFLEX01 Development Board (see Figure 2), and can easily be adapted to other hardware. See the Texas Instruments website for more information.



Figure 13 MSP-FET430UIF

IAR Embedded Workbench for MSP430

Also required is Embedded Workbench for TI MSP430 from IAR Systems. IAR Embedded Workbench for MSP430 is an integrated development environment for building and debugging embedded applications. Visit the IAR Systems website for additional information.

ELECTRICAL SPECIFICATIONS

The majority of these characteristics are based on the use of the TI 802.15.4 MAC loaded with the generic application firmware written by LSR. Custom firmware may require these values to be re-characterized by the customer.

Absolute Maximum Ratings

Parameter	Min	Max	Unit
Power supply voltage (VCC)	-0.2	+3.6	V
Voltage on any GPIO	-0.2	VCC + 0.2	V
RF input power, antenna port		+10	dBm
RF input power, transmit port		+8	dBm
Operating temperature	-40	+85	°C
Storage temperature	-40	+105	°C

Table 3 Absolute Maximum Ratings¹

Recommended Operating Conditions

Parameter	Min	Typ	Max	Unit
Power supply voltage (VCC)	2.2		3.3	Vdc
Input frequency	2405		2480	MHz
Ambient temperature range	-40	25	85	°C

Table 4 Recommended Operating Conditions

Module will NOT transmit, if VCC > 3.4V.

¹ Under no circumstances should exceeding the ratings specified in the Absolute Maximum Ratings section be allowed. Stressing the module beyond these limits may result permanent damage to the module that is not covered by the warranty.

General Characteristics

Parameter	Min	Typ	Max	Unit
RF frequency range	2405		2480	MHz
RF data rate		250		kbps
Host data rate	1.2	19.2	921.6	kbps
Flash memory		256		kB
RAM		16		kB
Flash information memory		512		Bytes

Table 5 General Characteristics

Power Consumption

Parameter	Test Conditions	Min	Typ	Max	Unit
Transmit mode	2440 MHz, 3.3V, +25°C	125	145	175	mA
Receive mode	2440 MHz, 3.3V, +25°C, -50 dBm input	25	30	35	mA
Sleep mode			3	8	uA

Table 6 Power Consumption

DC Characteristics – General Purpose I/O

Parameter	Test Conditions	Min	Typ	Max	Unit
Logic input low		-0.2		20% VCC	V
Logic input high		80% VCC		VCC + 0.2	V
Logic output low (Full Drive)	I _{out} = 5 mA	VSS		VSS + 0.25	V
	I _{out} = 15 mA	VSS		VSS + 0.60	V
Logic output low (Reduced Drive)	I _{out} = 2 mA	VSS		VSS + 0.25	V
	I _{out} = 6 mA	VSS		VSS + 0.60	V
Logic output high (Full Drive)	I _{out} = -5 mA	VCC - 0.25		VCC	V
	I _{out} = -15 mA	VCC - 0.60		VCC	V
Logic output high (Reduced Drive)	I _{out} = -2 mA	VCC - 0.25		VCC	V
	I _{out} = -6 mA	VCC - 0.60		VCC	V

Table 7 DC Characteristics General Purpose I/O

RF Characteristics

Transmitter Characteristics
(TA =25°C, VCC=3.3 V, fc =2440 MHz)

Parameter	Test Conditions	Min	Typ	Max	Unit
Nominal output power	100mW	18	20	21	dBm
Programmable output power range		7		20	dB
Error vector magnitude			12	35	%

Table 8 Transmitter RF Characteristics

LSR Host RF Power Value	CC2520 TXPOWER Register Value	RF Output Power	Typical Current Consumption
0	0x49	7 dBm	75 mA
1			
2			
3			
4			
5			
6			
7			
8			
9			
10	0x79	12 dBm	85 mA
11			
12			
13	0x6C	16 dBm	100 mA
14			
15	0xE0	18 dBm	115 mA
16			
17	0xF9	20 dBm	145 mA
18			
19			

Table 9 RF Power Settings with LSR Host Software

The information in this document is subject to change without notice.

Tables 10-12 below list the RF Power Limits per channel that must be maintained to assure compliance with FCC or ETSI.

RF Channel	Max LSR Host RF Power Value	CC2520 TXPOWER Register Value	RF Output Power
11	16	0xE0	18 dBm
12	16	0xE0	18 dBm
13	16	0xE0	18 dBm
14	19	0xF9	20 dBm
15	19	0xF9	20 dBm
16	19	0xF9	20 dBm
17	19	0xF9	20 dBm
18	19	0xF9	20 dBm
19	19	0xF9	20 dBm
20	19	0xF9	20 dBm
21	19	0xF9	20 dBm
22	19	0xF9	20 dBm
23	19	0xF9	20 dBm
24	19	0xF9	20 dBm
25	16	0xE0	18 dBm
26	Not used	Not used	Not used

Table 10 RF Transmit Output Power Limits for FCC Compliance (Internal or External Antenna)

RF Channel	Max LSR Host RF Power Value	CC2520 TXPOWER Register Value	RF Output Power
11	12	0x79	12 dBm
12	12	0x79	12 dBm
13	12	0x79	12 dBm
14	12	0x79	12 dBm
15	12	0x79	12 dBm
16	12	0x79	12 dBm
17	12	0x79	12 dBm
18	12	0x79	12 dBm
19	12	0x79	12 dBm
20	12	0x79	12 dBm
21	12	0x79	12 dBm
22	12	0x79	12 dBm
23	12	0x79	12 dBm
24	12	0x79	12 dBm
25	12	0x79	12 dBm
26	12	0x79	12 dBm

Table 11 RF Transmit Output Power Limits for ETSI Compliance (Internal Antenna)

RF Channel	Max LSR Host RF Power Value	CC2520 TXPOWER Register Value	RF Output Power
11	9	0x49	7 dBm
12	9	0x49	7 dBm
13	9	0x49	7 dBm
14	9	0x49	7 dBm
15	9	0x49	7 dBm
16	9	0x49	7 dBm
17	9	0x49	7 dBm
18	9	0x49	7 dBm
19	9	0x49	7 dBm
20	9	0x49	7 dBm
21	9	0x49	7 dBm
22	9	0x49	7 dBm
23	9	0x49	7 dBm
24	9	0x49	7 dBm
25	9	0x49	7 dBm
26	9	0x49	7 dBm

Table 12 RF Transmit Output Power Limits for ETSI Compliance (External Antenna)

Receiver Characteristics
(TA =25°C, VCC=3.3 V, fc =2440 MHz)

Parameter	Test Conditions		Min	Typ	Max	Unit
Receiver sensitivity (1% PER)	HGM		-95	-98	-99	dBm
Saturation (maximum input level) (1% PER)	HGM			-13		dBm
Interference rejection	Desired signal at -82 dBm, 802.15.4 interferer	±5 MHz		51		dB
		±10 MHz		56		dB
		±20 MHz		57		dB

Table 13 Receiver RF Characteristics

For additional details regarding the electrical specifications, see the MSP430F5437, CC2520, and CC2591 datasheets on the TI website.

SOLDERING RECOMMENDATIONS

Recommended Reflow Profile for Lead Free Solder

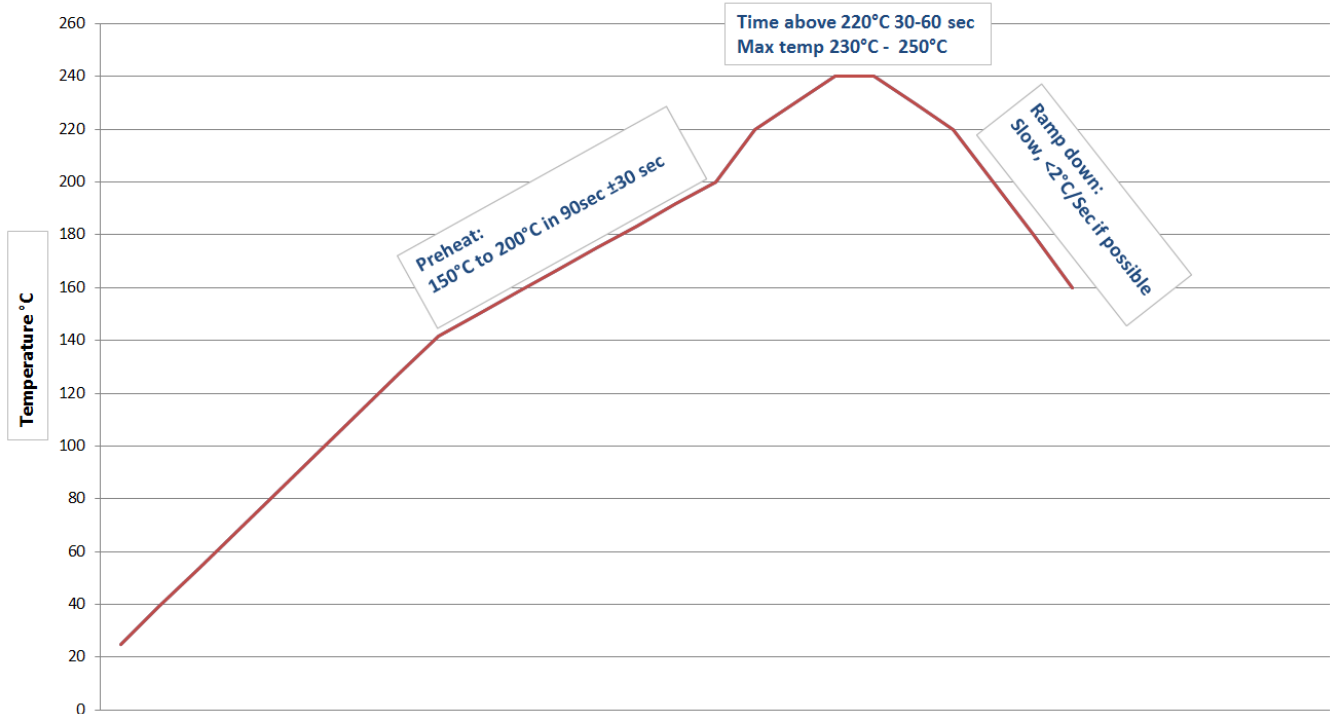

Note: The quality of solder joints on the castellations ('half vias') where they contact the host board should meet the appropriate IPC Specification. See IPC-A-610-D Acceptability of Electronic Assemblies, section 8.2.4 Castellated Terminations."

CLEANING

In general, cleaning the populated modules is strongly discouraged. Residuals under the module cannot be easily removed with any cleaning process.

- Cleaning with water can lead to capillary effects where water is absorbed into the gap between the host board and the module. The combination of soldering flux residuals and encapsulated water could lead to short circuits between neighboring pads. Water could also damage any stickers or labels.
- Cleaning with alcohol or a similar organic solvent will likely flood soldering flux residuals into the RF shield, which is not accessible for post-washing inspection. The solvent could also damage any stickers or labels.
- Ultrasonic cleaning could damage the module permanently.

OPTICAL INSPECTION

After soldering the Module to the host board, consider optical inspection to check the following:

- Proper alignment and centering of the module over the pads.
- Proper solder joints on all pads.
- Excessive solder or contacts to neighboring pads, or vias.

REWORK

The ProFLEX01 module can be unsoldered from the host board. Use of a hot air rework tool and hot plate for pre-heating from underneath is recommended. Avoid overheating.

Never attempt a rework on the module itself, e.g. replacing individual components. Such actions will terminate warranty coverage.

SHIPPING, HANDLING, AND STORAGE

Shipping

Bulk orders of the ProFLEX01 modules are delivered in trays of 50.

Handling

The ProFLEX01 modules contain a highly sensitive electronic circuitry. Handling without proper ESD protection may destroy or damage the module permanently. ESD protection may destroy or damage the module permanently.

Moisture Sensitivity Level (MSL)

MSL 4, per J-STD-020

Devices not stored in a sealed bag with desiccant pack should be baked.

After opening devices that will be subjected to reflow must be mounted within 72 hours of factory conditions (<30°C and 60% RH) or stored at <10% RH.

Bake devices for 8 hours at 125°C.

Storage

Storage/shelf life in sealed bags is 12 months at <40°C and <90% relative humidity.

Repeating Reflow Soldering

Only a single reflow soldering process is encouraged for host boards.