



Chipsmall Limited consists of a professional team with an average of over 10 year of expertise in the distribution of electronic components. Based in Hongkong, we have already established firm and mutual-benefit business relationships with customers from,Europe,America and south Asia,supplying obsolete and hard-to-find components to meet their specific needs.

With the principle of “Quality Parts,Customers Priority,Honest Operation,and Considerate Service”,our business mainly focus on the distribution of electronic components. Line cards we deal with include Microchip,ALPS,ROHM,Xilinx,Pulse,ON,Everlight and Freescale. Main products comprise IC,Modules,Potentiometer,IC Socket,Relay,Connector.Our parts cover such applications as commercial,industrial, and automotives areas.

We are looking forward to setting up business relationship with you and hope to provide you with the best service and solution. Let us make a better world for our industry!



## Contact us

Tel: +86-755-8981 8866 Fax: +86-755-8427 6832

Email & Skype: info@chipsmall.com Web: www.chipsmall.com

Address: A1208, Overseas Decoration Building, #122 Zhenhua RD., Futian, Shenzhen, China



# SABLE-X DEVELOPMENT BOARD

## User Guide



Last updated  
February 5<sup>th</sup>, 2015

## Table of Contents

### User Guide 1

<b>1</b>	<b>Introduction .....</b>	<b>3</b>
1.1	<i>Purpose &amp; Scope .....</i>	3
1.2	<i>Applicable Documents .....</i>	3
1.3	<i>Revision History .....</i>	3
<b>2</b>	<b>SaBLE-x Development Board Description .....</b>	<b>4</b>
<b>3</b>	<b>SaBLE-x Development Board Hardware .....</b>	<b>7</b>
3.1	<i>Antennas and RF Connector .....</i>	7
3.2	<i>Interface Connectors.....</i>	8
3.3	<i>Development Board Power .....</i>	11
3.4	<i>Bus Isolation DIP Switches .....</i>	12
3.5	<i>User Input Push Button Switches .....</i>	13
3.6	<i>Sensors .....</i>	13
3.7	<i>External Memory .....</i>	14
3.8	<i>LED Indicators.....</i>	15
<b>4</b>	<b>SaBLE-x Development Board Schematics .....</b>	<b>16</b>
<b>5</b>	<b>Adapter Boards.....</b>	<b>17</b>
<b>6</b>	<b>Evaluation and Development .....</b>	<b>26</b>
6.1	<i>Overview .....</i>	26
6.2	<i>Evaluation/Development Options.....</i>	26
6.3	<i>Programming and Debugging .....</i>	27
<b>7</b>	<b>Contacting LSR.....</b>	<b>31</b>

## 1 Introduction

### 1.1 Purpose & Scope

The purpose of this document is to provide details regarding the setup and use of the SaBLE-x module on a Development Board. This document covers a description of the Development Board, its features, and a brief tutorial on how to operate the module Development Board.

### 1.2 Applicable Documents

- SaBLE-x Datasheet (330-0166)
- SaBLE-x Application Guide (330-0167)

### 1.3 Revision History

Date	ECN	Change Description	Revision
5/19/2015	105-2015	Initial release	1.0
10/5/15	192-2015	Added bootloader config information and FTDI VCP driver link	1.1
12/2/2015	221-2015	Fixed XDS110 debugger info	1.2
12/4/2015	225-2015	Replaced reference to SmartRF05 board to SmartRF06 in Section 5.1.4	1.3
2/5/2016	20-2016	Updated to Laird Color Scheme	1.4

**Table 1 Revision History**

The information in this document is subject to change without notice.

## 2 SaBLE-x Development Board Description

The SaBLE-x Development Board is an evaluation and development platform for the LSR SaBLE-x Bluetooth Smart Module. The SaBLE-x Development Board provides all of the necessary connectors, jumpers, indicators, and switches to test and debug all aspects of the SaBLE-x module. The connectors and switches on the Development Board make it a convenient platform for product development, as it allows a means to disconnect the on board peripherals and IO, and provides an easy means to connect your own IO.

The Development Board also has flexible power options that support a coin cell battery, external power supply, or USB power.

The SaBLE-x Development Board can be used to evaluate basic BLE connectivity. Additionally it is possible to put the SaBLE-x Module into static RF test modes so that RF performance can be evaluated.

The SaBLE-x Development Board contains an FTDI USB to TTL UART IC. When the dev board is plugged into a PC it will show up in the device manager as a virtual COM port. If the PC is missing the driver, it can be downloaded from FTDI: <http://www.ftdichip.com/Drivers/VCP.htm>

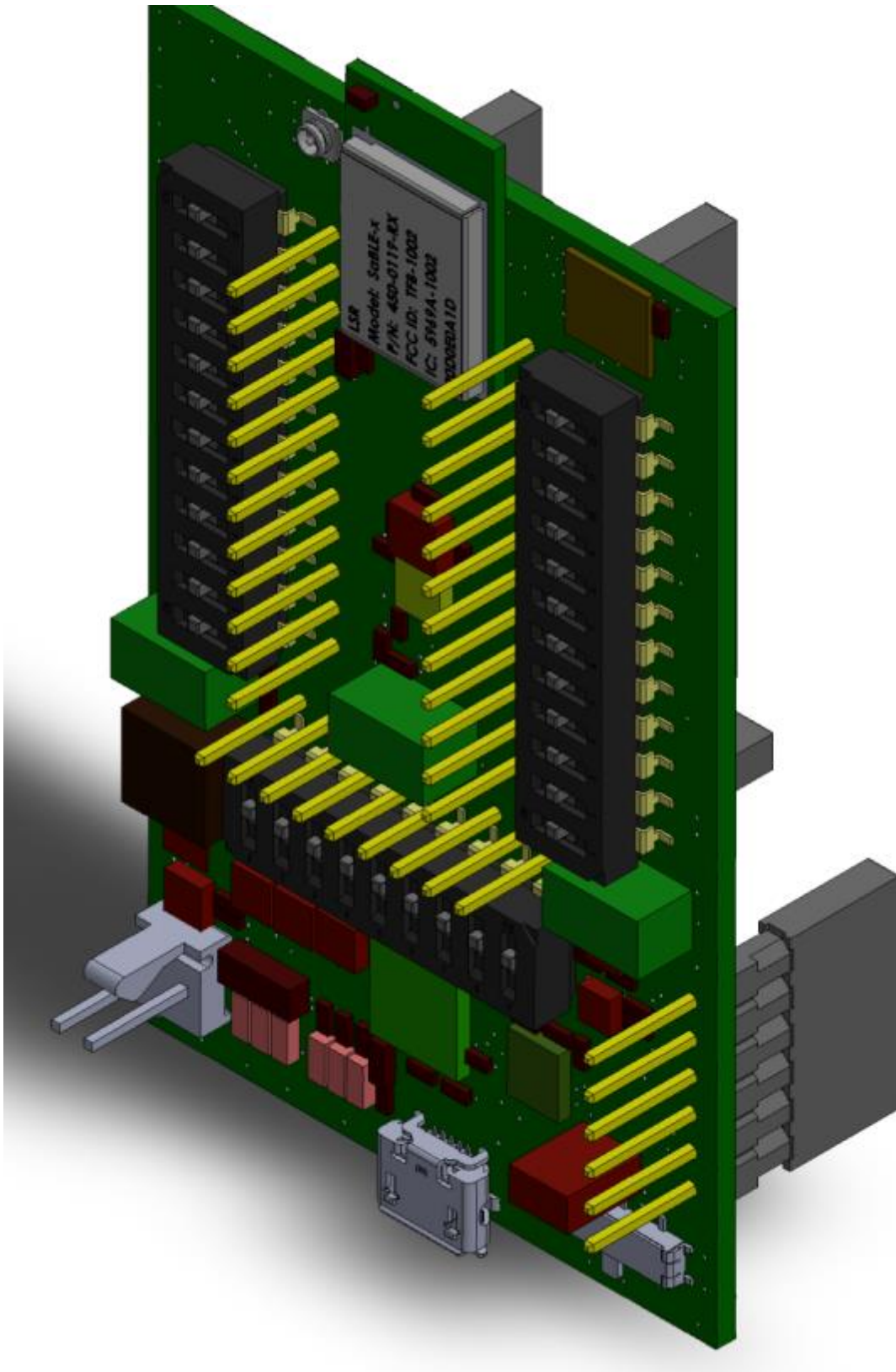

Figure 1 SaBLE-x Development Board Viewed from Top

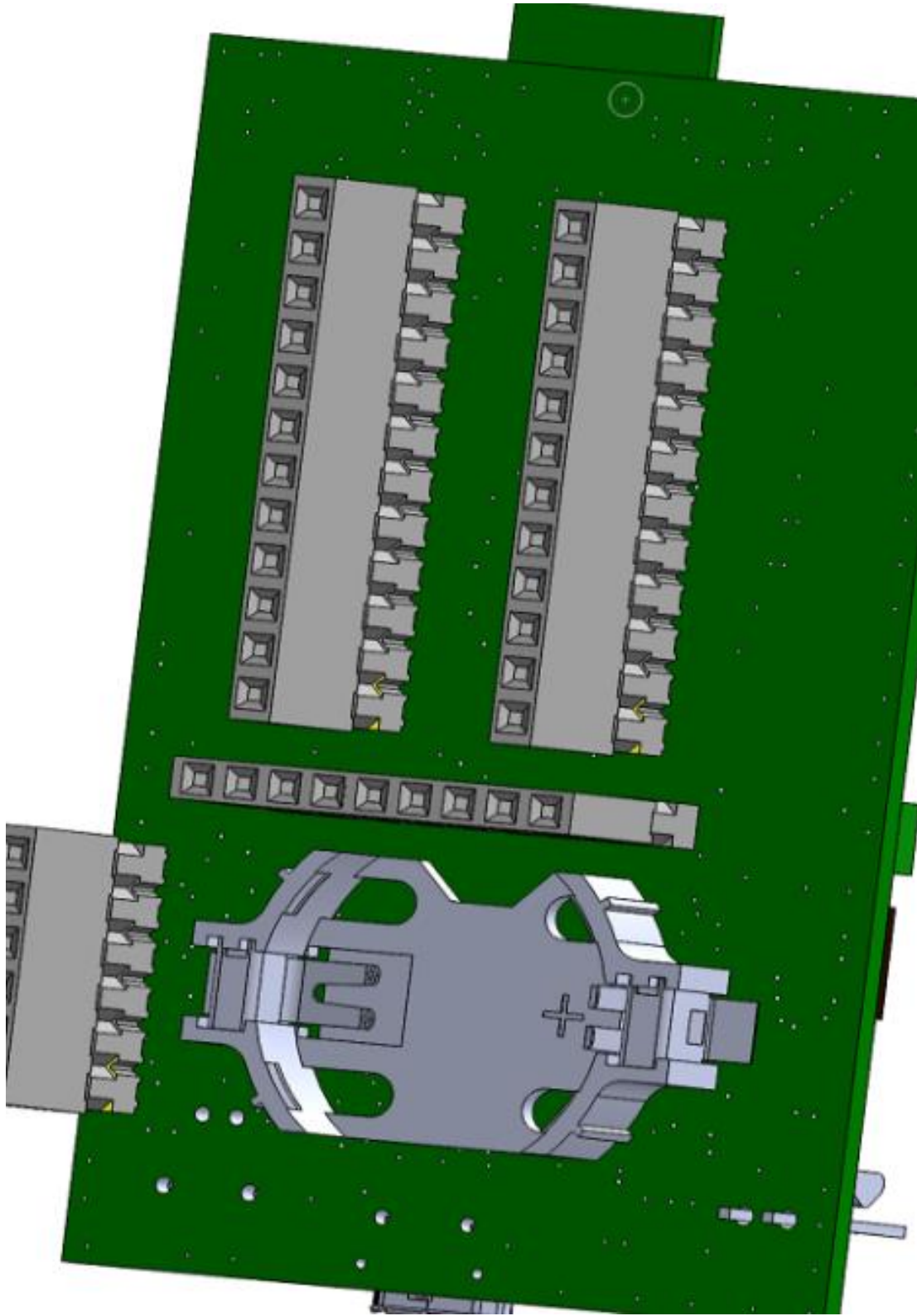

Figure 2 SaBLE-x Development Board Viewed From Bottom

### 3 SaBLE-x Development Board Hardware

Please refer to the Reference Design Schematic, the Reference Design PCB, and the Reference Design BOM in the SaBLE-x Module User Guide for more detail on the SaBLE-x reference design PCB. Note that the Reference Design PCB files are available for download on the LSR website.

#### 3.1 Antennas and RF Connector

There are two SaBLE-x Module versions:

LSR Part Number	Description
450-0119	SaBLE-x Module, PCB Trace Antenna
450-0144	SaBLE-x Module, External Antenna Port (Onboard Antenna Disabled)

**Table 2 Module Part Numbers**

The SaBLE-x Development Board includes an on board U.FL RF connector J3 (**Figure 3**). When used in conjunction with SaBLE-x Module with External Antenna Port, J3 provides a RF connection point to external antennas or test equipment. When the SaBLE-x Development Board is used with used with SaBLE-x Module with PCB Trace Antenna, the U.FL connector has no electrical connection to the SaBLE-x Module.

The SaBLE-x Module is EMC certified for FCC, IC, ETSI, Japan, and Australia/New Zealand. See the SaBLE-x datasheet and application guide for further information regarding EMC certifications.

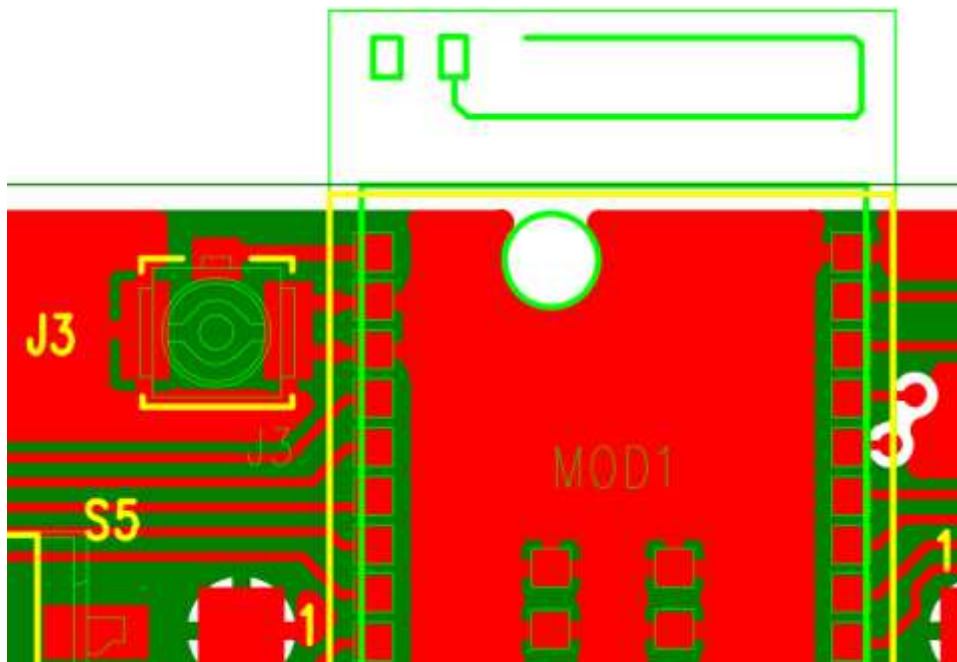

**Figure 3 RF Connector J3**



### 3.2 Interface Connectors

The LSR SaBLE-x development board has 4 connectors, J1, J2, J4, and J5 for interfacing to LSR Adapter Boards, as well as various prototyping platforms. The connectors provide access to all of the I/O on the SaBLE-x module with a dual purpose .1" (2.54mm) connector that allows for mating to either male pins or female sockets. Refer to **Table 3**, **Table 4**, **Table 5**, and **Table 6** for details on the signals brought out to these connectors.

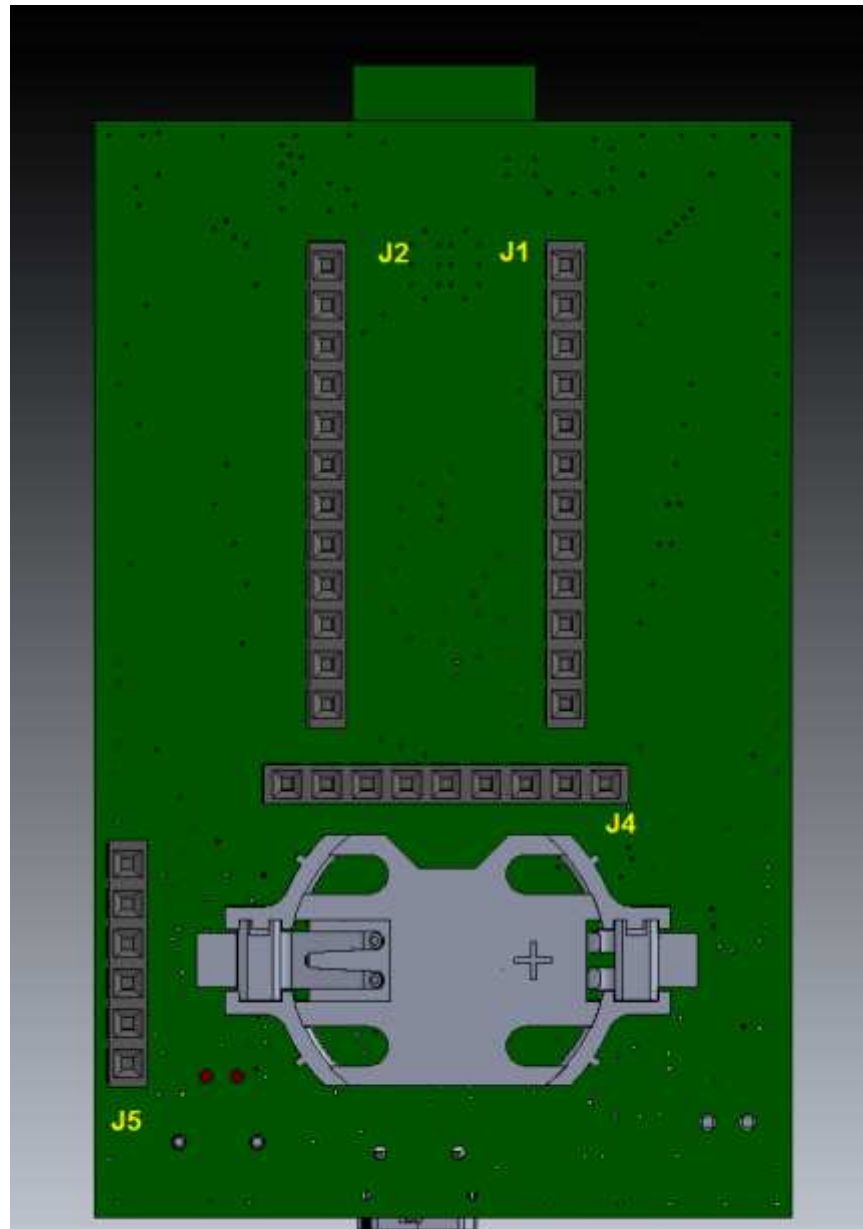

Figure 4 SaBLE-x Dev Board Connectors

J1 Pin Number	Pin Name	Module Pin Type	Description
1	GND	Ground	Ground
2	GND	Ground	Ground
3	GND	Ground	Ground
4	NC	NC	Not Connected
5	NC	NC	Not Connected
6	/RESET	DI	Module Reset (Active Low)
7	JTAG_TCKC	Digital I/O	JTAG_TCKC
8	JTAG_TMSC	Digital I/O	JTAG_TMSC
9	NC	NC	Not Connected
10	NC	NC	Not Connected
11	VCC	Power	Power Supply Input (1.8v to 3.8v)
12	VCC	Power	Power Supply Input (1.8v to 3.8v)

**Table 3 Connector J1 Pinout**

J2 Pin Number	Pin Name	Module Pin Type	Description
1	GND	Ground	Ground
2	DIO 14	DIO	GPIO, Analog Input, ULP Sensor Interface
3	DIO 13	DIO	GPIO, Analog Input, ULP Sensor Interface
4	DIO 12	DIO	GPIO, Analog Input, ULP Sensor Interface
5	DIO 11	DIO	GPIO, Analog Input, ULP Sensor Interface
6	NC	NC	Not Connected
7	NC	NC	Not Connected
8	NC	NC	Not Connected
9	NC	NC	Not Connected
10	DIO 9	DIO	GPIO, Analog Input, ULP Sensor Interface
11	DIO 10	DIO	GPIO, Analog Input, ULP Sensor Interface
12	GND	Ground	Ground

**Table 4 Connector J2 Pinout**

J4 Pin Number	Pin Name	Module Pin Type	Description
1	DIO 5 JTAG_TDO	DIO	GPIO, JTAG_TDO, ULP Sensor Interface, LED Driving Capability
2	DIO 6 JTAG_TDI	DIO	GPIO, JTAG_TDO, ULP Sensor Interface, LED Driving Capability
3	DIO 4	DIO	GPIO, LED Driving Capability
4	DIO 3	DIO	GPIO, LED Driving Capability
5	DIO 2	DIO	GPIO, ULP Sensor Interface, LED Driving Capability
6	DIO 1 / BOOT RX	DIO	GPIO, ULP Sensor Interface, Bootloader RX (UART0)
7	DIO 0 / BOOT TX	DIO	GPIO, ULP Sensor Interface, Bootloader TX (UART0)
8	DIO 7	DIO	GPIO, ULP Sensor Interface
9	DIO 8	DIO	GPIO, ULP Sensor Interface

**Table 5 Connector J4 Pinout**

J5 Pin Number	Pin Name	Module Pin Type	Description
1	EXT 3V3	Power	External Power Supply to Module
2	EXT DIO 0 / BOOT TX	DIO	GPIO, ULP Sensor Interface, Bootloader TX (UART0) External, Switched
3	EXT DIO 1 / BOOT RX	DIO	GPIO, ULP Sensor Interface, Bootloader RX (UART0) External, Switched
4	EXT /RESET	DIO	Module Reset (Active Low), External, Switched
5	EXT DIO 9 / BOOT EN	DIO	Boot Enable, External, Switched
6	GND	Ground	Ground

**Table 6 Connector J5 Pinout**

### 3.3 Development Board Power

The SaBLE-x Development board provides 4 possible sources for powering the SaBLE-x module and development board peripherals.

#### 3.3.1 Power Connectors

- B1 - 3V Lithium Coin Cell Battery
- J6 - External Power Supply (2.3v to 3.6v)
- J9 - 5V USB Power (Regulated by U5 to 3.3V)
- J5 - Power directly to the SaBLE-x module PIN1 and PIN6 (2.3v to 3.6v)

NOTE: On the first batch of Development Boards the silk screen does not align correctly with the actual slide switch positions. As such start with the switch at one end and count the detents as you slide it to insure it is in the intended position.

#### 3.3.2 Power Selection

Switch S4 is a 4 position slide switch that acts as on/off switch to the development board and the SaBLE-x module. It also provides a means of selecting the source of powering the development board. Jumper J4, located next to S4, provide a means of isolating power going to the module for the purpose of measuring module current (**Figure 5**).

NOTE: When using the SaBLE-x TI Adapter Board in conjunction with the Development Board, power is supplied from the TI evaluation platform, and switch S4 must be in the OFF position.

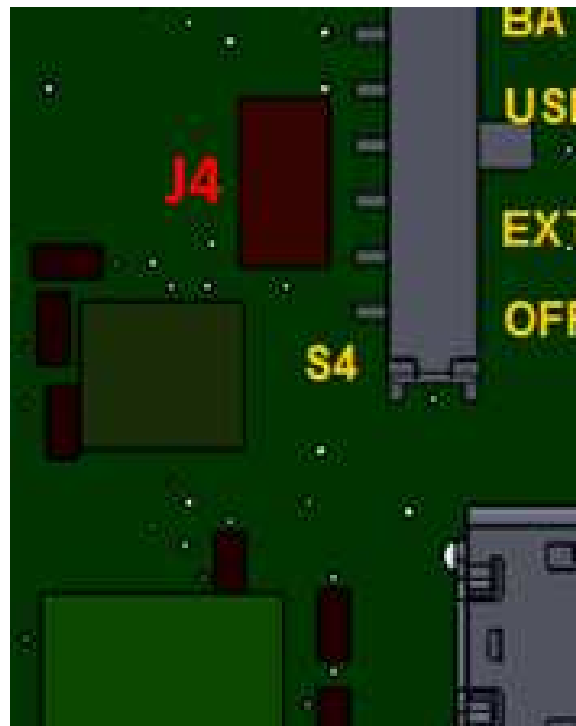

Figure 5 Power Switch S4

### 3.4 Bus Isolation DIP Switches

DIP switch SW 5, 6, and 7 provide a means of individually isolating the SaBLE-x Module pins from the various hardware of the development board. When in the off (open) position, the corresponding pin of the SaBLE-x module is isolated to the corresponding interface connector.

In addition to the bus isolation switches, U3 adds additional protection against Bus contention UART and enable line when an external is sensed on J5.

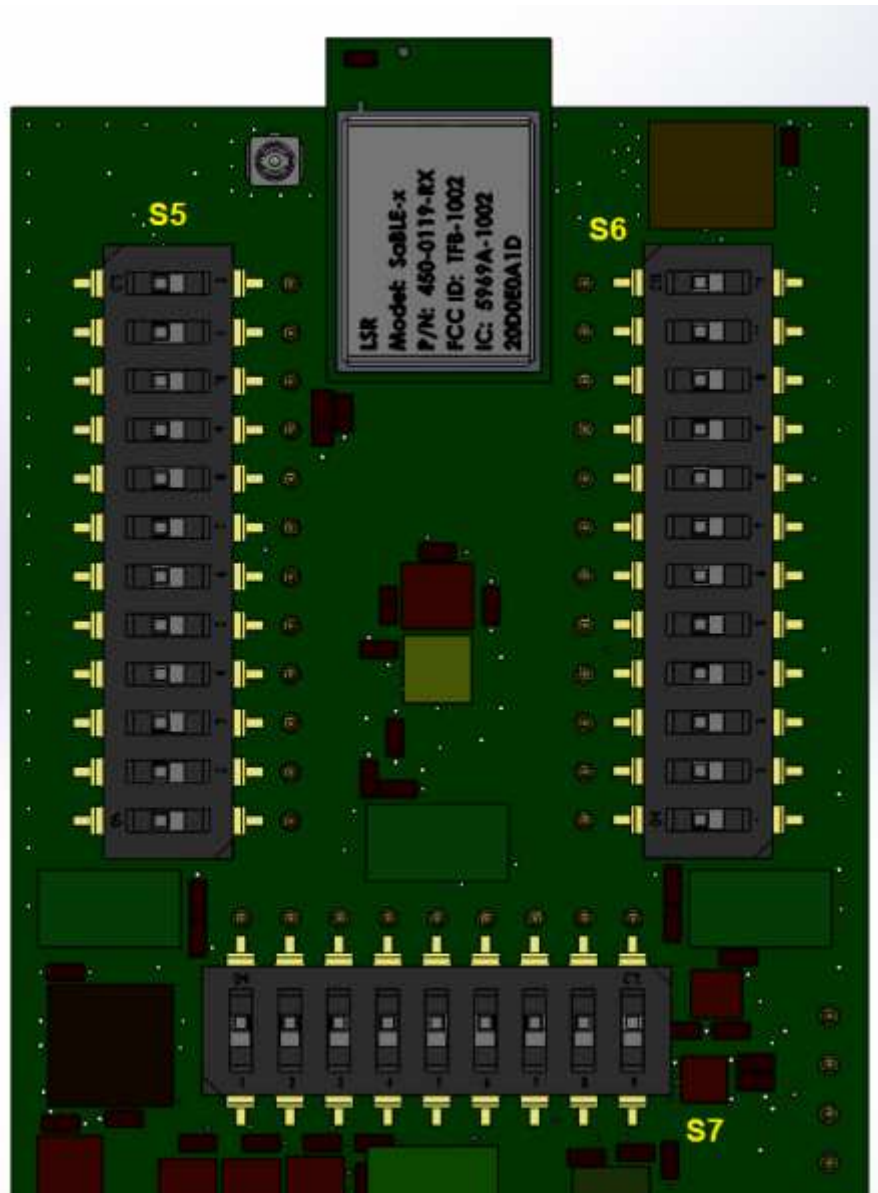

Figure 6 Bus Isolation Switches

### 3.5 User Input Push Button Switches

There are 3 push button switches on the SaBLE-x Development board which allow user input to the module.

- S1 - User Defined Switch
- S2 - Module Reset
- S3 - Bootload Enable (enables bootloader function on the SaBLE-x Module)

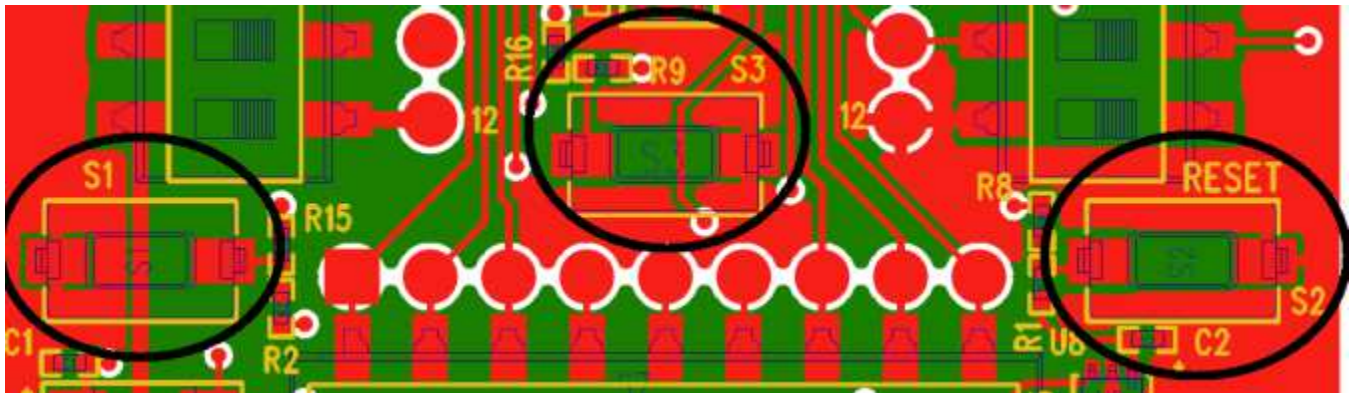

Figure 7 Push Button Switches

### 3.6 Sensors

The SaBLE-x Development Board includes 3 sensors connected to the SaBLE-x Module on a common I2C interface.

- U1 - Temperature Sensor (provides Dev Board temperature)
- U7 - Tri-Axis Accelerometer (provides tilt, roll, and yaw attitude of the Dev Board)
- U9 - Ambient Light Sensor (provides Dev Board ambient light intensity)

### 3.6.1 I2C Interface To Sensors

The SaBLE-x Development Board includes an I2C interface. The I2C provides an interface between the SaBLE-x Module and the on board temperature sensor (U1), accelerometer (U7) and ambient light sensor (U9), as well as other I2C compatible devices connected by the two-wire I2C serial bus. External components attached to the I2C bus communicate serial data to and from the SaBLE-x Module through the two-wire I2C interface. The I2C bus supports any slave or master I2C compatible device.

Figure 8 shows an example of an I2C bus. Each I2C device is recognized by a unique address and can operate as either a transmitter or a receiver. A device connected to the I2C bus is either a master or a slave when performing data transfers. A master initiates a data transfer and generates the clock signal (SCL). Any device addressed by a master is considered a slave. I2C data is communicated using the serial data (SDA) pin and the serial clock (SCL) pin.

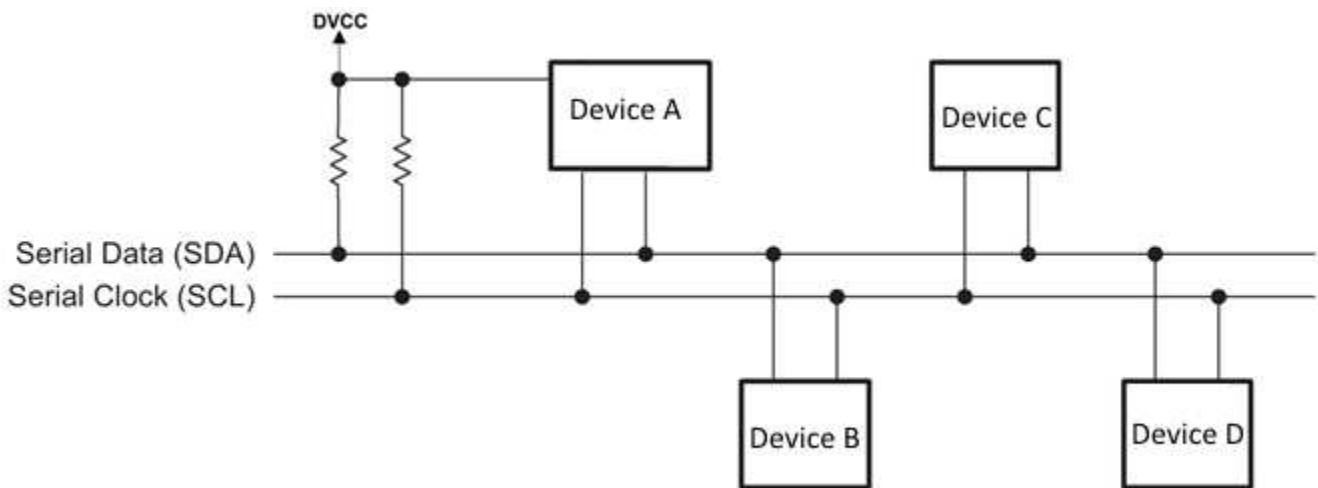

**Figure 8 I2C Interface SaBLE-x Development Board Schematic**

### 3.6.2 I2C Device Addresses

Each I2C device is recognized by a unique address. Any additional devices added to the SaBLE-x Dev Board I2C bus cannot replicate the existing addresses.

- U1 - Temperature Sensor - 1001111 (0x4F)
- U7 - Tri-Axis Accelerometer - 0001111 (0x0F)
- U9 - Ambient Light Sensor - 1001010 (0x4A)

## 3.7 External Memory

U4 on the Dev Board provides a user accessible 4Mbit CMOS Serial Flash Memory, on a SPI interface to the SaBLE-x Module.

### 3.8 LED Indicators

Several LEDs on the development board provide means of visual interface between the Dev Board and the user.

- LED 1 - USB Power Indicator, Blue LED
- LED 2 - USB UART TX Data Activity, Red LED
- LED 6 - USB UART RX Data Activity, Green LED
- LED 3 - User Defined Blue LED (transistor buffered)
- LED 4 - User Defined Red LED (transistor buffered)
- LED 5 - User Defined Green LED (transistor buffered)

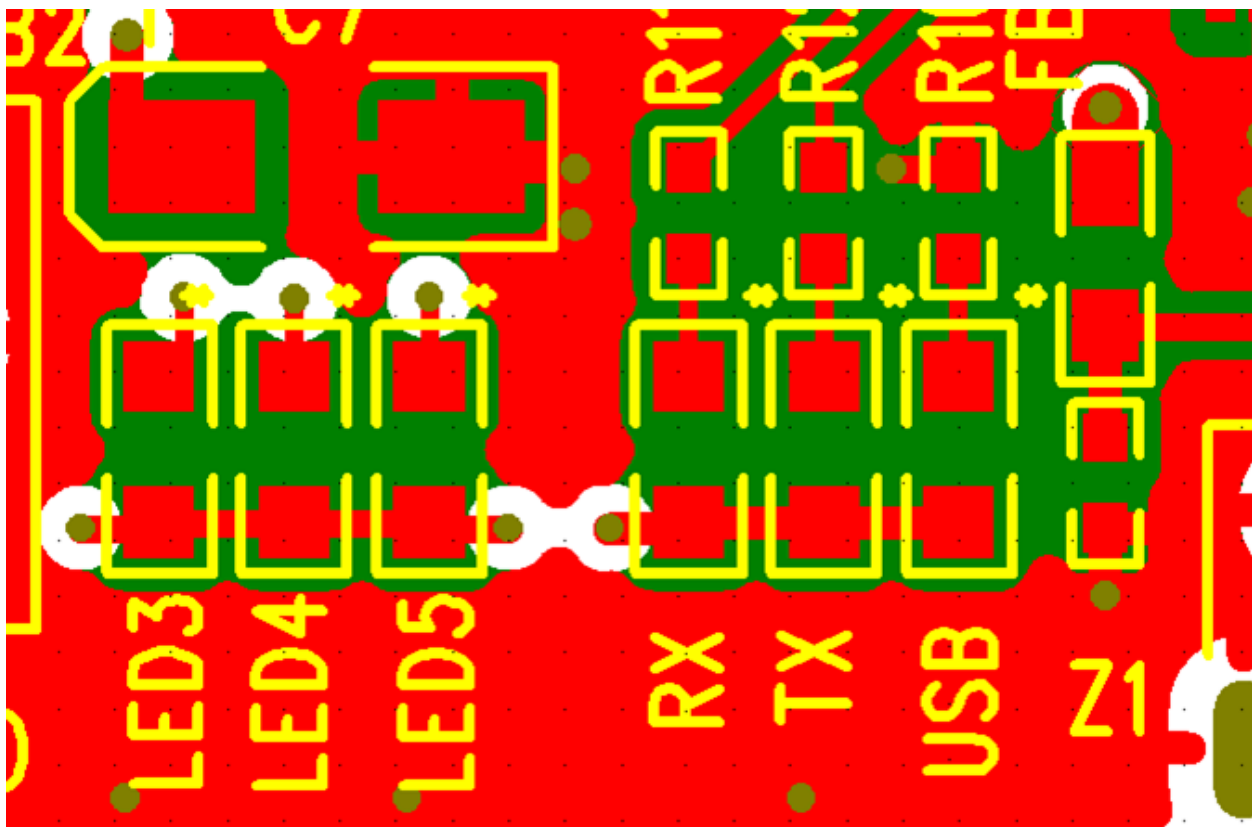

Figure 9 LEDs



## 4 SaBLE-x Development Board Schematics

See the LSR website for the full PCB, Schematic, and BOM of the SaBLE-x Development Board.

## 5 Adapter Boards

In addition the Dev Board, there are also two Adapter Boards which make it easy to adapt the SaBLE-x Dev Board to popular development platforms such as Arduino and various Texas Instruments (TI) platforms.

LSR Part Number	Description
940-0126	PCBA, SaBLE-x Dev Board to Arduino Adapter
940-0125	PCBA, SaBLE-x Dev Board to TI Adapter

**Table 7 Adapter Board Part Numbers**

### 5.1.1 Arduino Adapter Board

The SaBLE-x Dev Board to Arduino Adapter board provides a means for adapting the SaBLE-x Dev Board to the open-source hardware and software of the Arduino platform. The adapter board has all the Arduino pin-headers in the standard Arduino Shield PCB form factor. In addition, the adapter board contains a 3.3V regulator and level shifter circuit to convert between logic levels of the Arduino board and the 3.3V logic level of the Arduino Adapter board.

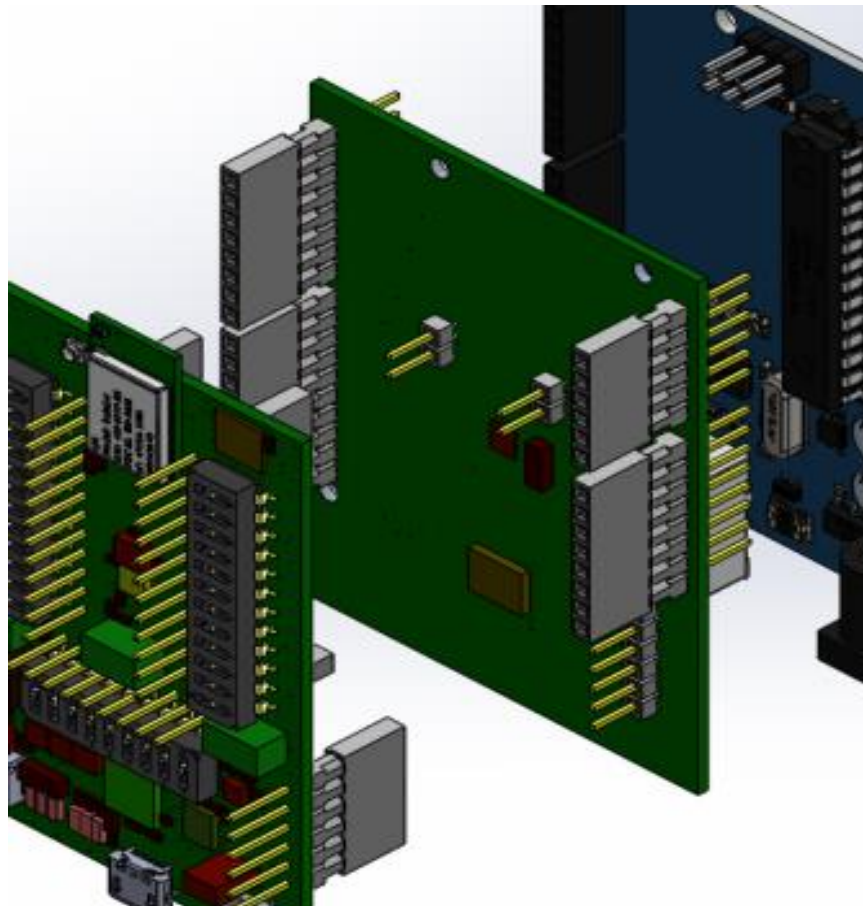

**Figure 10 Arduino Adapter Platform**

5.1.2 Arduino Adapter Board Connectors

J1 & J2 Pin Number	Pin Name	Module Pin Type	Description
1	NC	NC	Not Connected
2	NC	NC	Not Connected

Table 8 J1 and J2 Signals

J6 Pin Number	Pin Name	Module Pin Type	Description
1	NC	NC	Not Connected
2	NC	NC	Not Connected
3	NC	NC	Not Connected
4	NC	NC	Not Connected
5	NC	NC	Not Connected
6	NC	NC	Not Connected

Table 9 J6 Signals

J5 Pin Number	Pin Name	Module Pin Type	Description
1	3.3V	POWER	3.3V Regulated Power
2	UART TX	DIO	TX From Module (RX Arduino) – 3.3v Logic Level
3	UART RX	DIO	RX From Module (TX Arduino) – 3.3v Logic Level
4	RESET n	DIO	Module Reset (Active Low) – 3.3v Logic Level
5	BOOT ENABLE	DIO	Module Boot Enable (Active Low) – 3.3v Logic Level
6	GROUND	GND	Ground

Table 10 J5 Signals

J3 Pin Number	Pin Name	Module Pin Type	Description
1	NC	NC	Not Connected
2	NC	NC	Not Connected
3	UART TX	DIO	TX Module (RX Arduino) – Arduino Logic Level
4	NC	NC	Not Connected
5	NC	NC	Not Connected
6	NC	NC	Not Connected
7	NC	NC	Not Connected
8	NC	NC	Not Connected

Table 11 J3 Signals

The information in this document is subject to change without notice.

J4 Pin Number	Pin Name	Module Pin Type	Description
1	UART RX	DIO	RX From Module (TX Arduino) – Arduino Logic Level
2	NC	NC	Not Connected
3	NC	NC	Not Connected
4	NC	NC	Not Connected
5	NC	NC	Not Connected
6	NC	NC	Not Connected
7	GROUND	GND	Ground
8	NC	NC	Not Connected
9	NC	NC	Not Connected
10	NC	NC	Not Connected

**Table 12 J4 Signals**

J7 Pin Number	Pin Name	Module Pin Type	Description
1	NC	NC	Not Connected
2	GROUND	GND	Ground
3	GROUND	GND	Ground
4	5V	POWER	5V From Arduino
5	NC	NC	Not Connected
6	NC	NC	Not Connected
7	IOREF	POWER	Voltage From Arduino – Logic Level Reference
8	NC	NC	Not Connected

**Table 13 J7 Signals**

**5.1.3 Arduino Adapter Board Schematic**

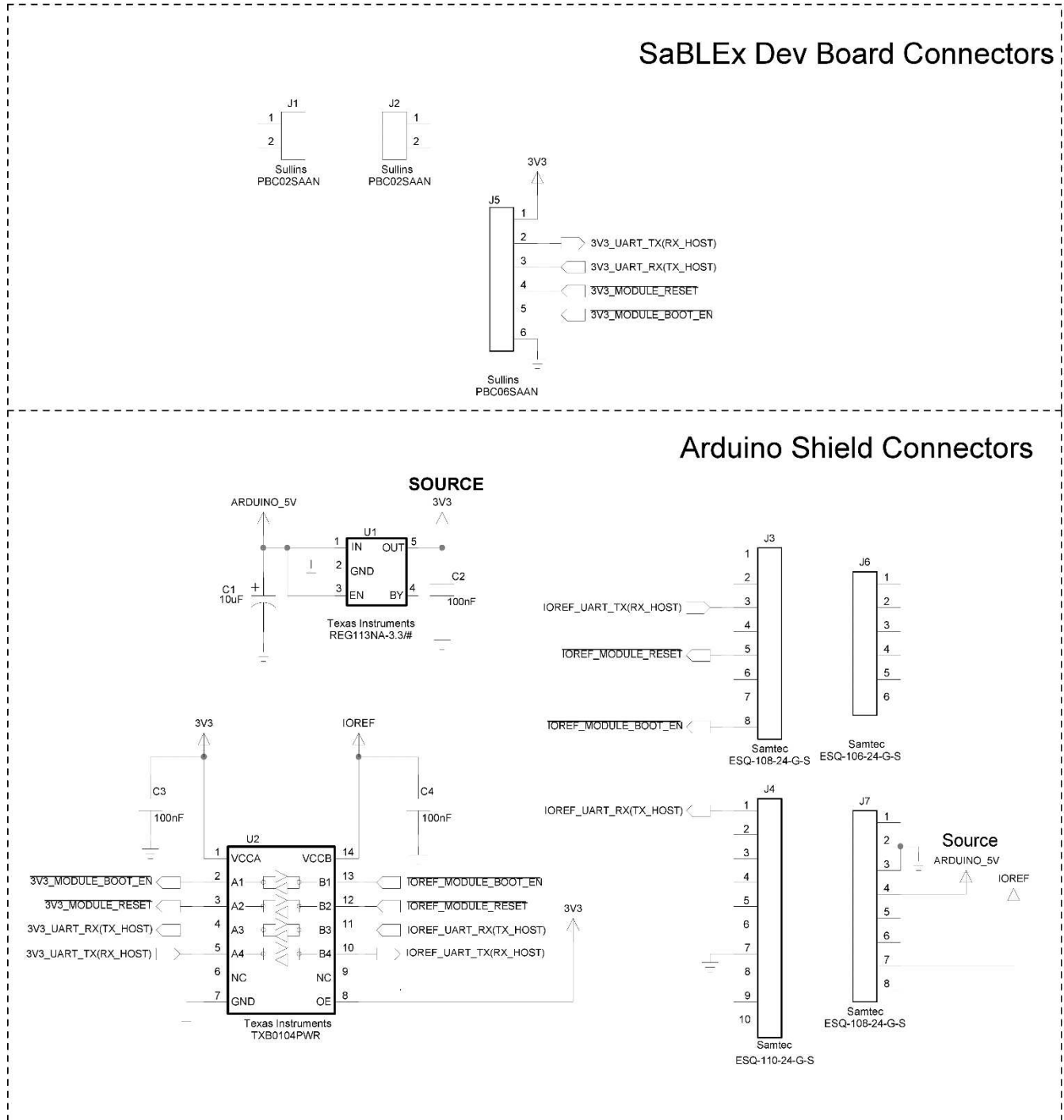

**Figure 11 SaBLE-x Development Board to Arduino Adapter Schematic**

The information in this document is subject to change without notice.

### 5.1.4 TI Adapter Board

The SaBLE-x Dev Board to TI Adapter board provides a means for adapting the SaBLE-x Dev Board to the various Texas Instruments development platforms that utilize the TI standard EM interface. Included with the LSR TI Adapter board is a break away connector board J4. J4 is required when using the Dev Board with the TI SmartRF06 Evaluation Board.

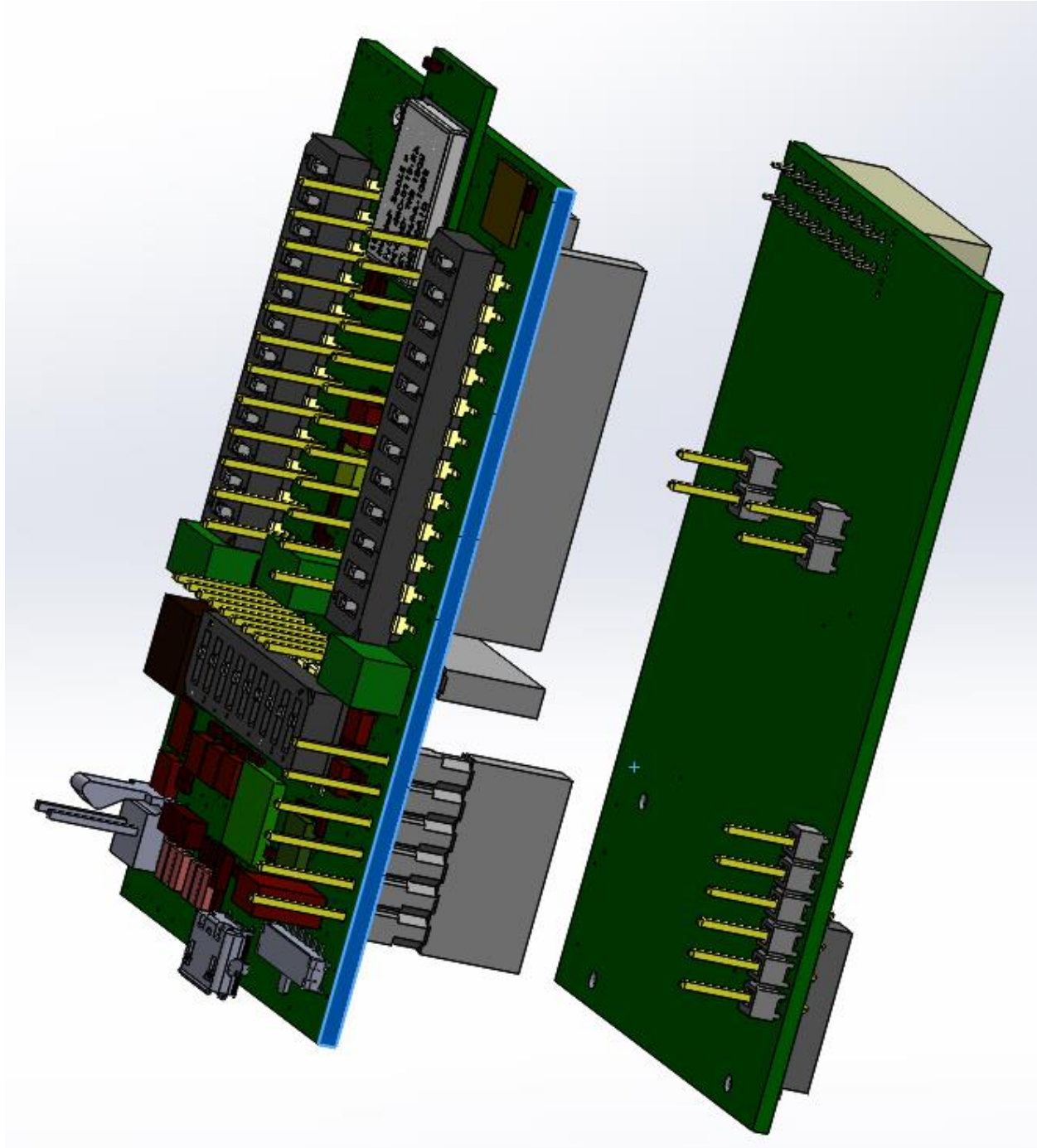

Figure 12 TI Adapter Platform (Top View)

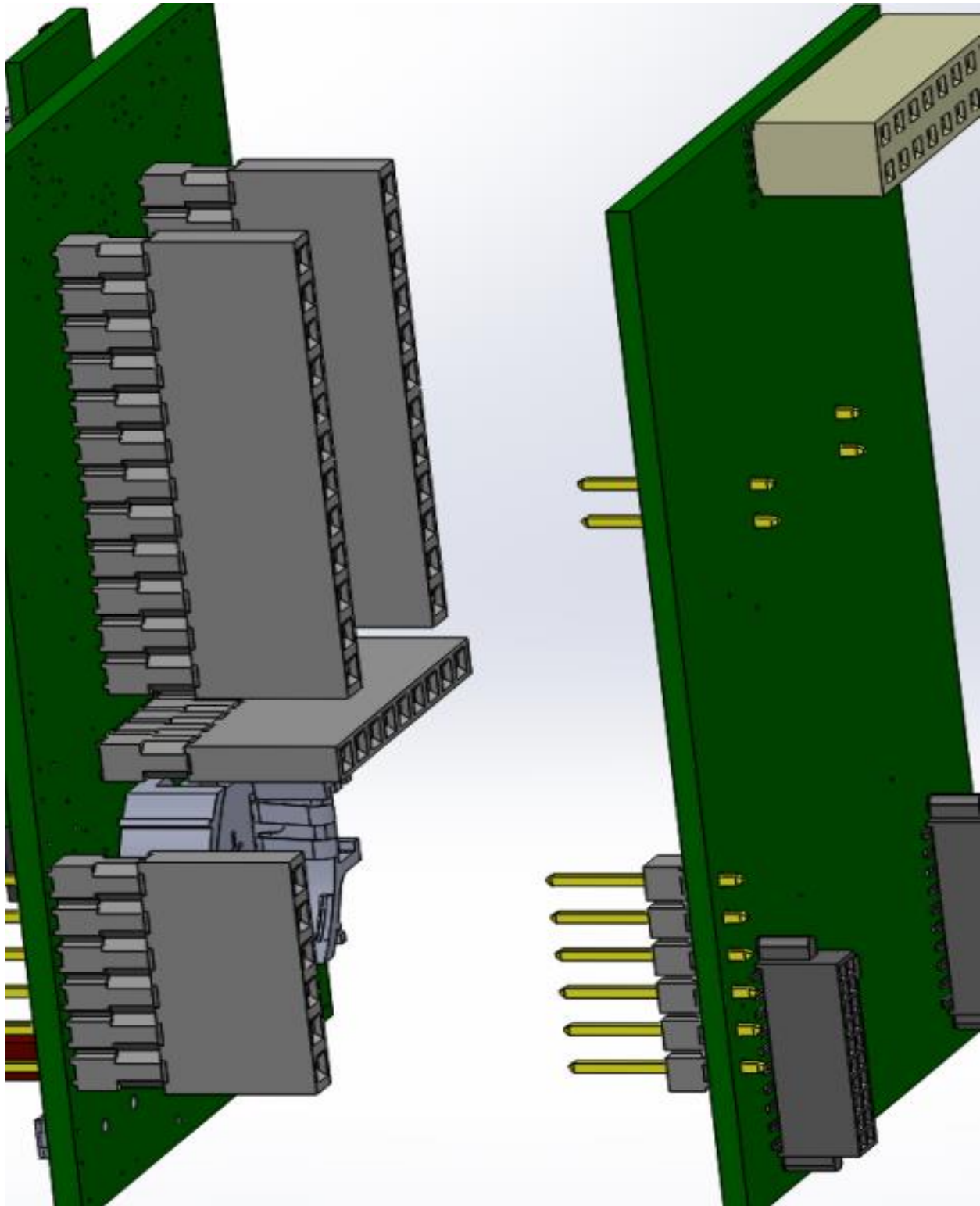

Figure 13 TI Adapter Platform (Bottom View)

**5.1.5 TI Adapter Board Connectors**

J5 Pin Number	Pin Name	Module Pin Type	Description
1	3.3V	POWER	3.3V From TI Eval Board
2	UART TX	DIO	TX From Module (RX TI Eval Board) – 3.3V Logic Level
3	UART RX	DIO	RX From Module (TX TI Eval Board) – 3.3V Logic Level
4	RESET n	DIO	Module Reset (Active Low) – 3.3V Logic Level
5	BOOT ENABLE	DIO	Module Boot Enable (Active Low) – 3.3V Logic Level
6	GROUND	GND	Ground

**Table 14 J5 Signals**

J1 Pin Number	Pin Name	Module Pin Type	Description
1	GROUND	GND	Ground
2	NC	NC	Not Connected
3	NC	NC	Not Connected
4	NC	NC	Not Connected
5	NC	NC	Not Connected
6	NC	NC	Not Connected
7	UART TX	DIO	TX From Module (RX TI Eval Board) – 3.3V Logic Level
8	NC	NC	Not Connected
9	UART RX	DIO	RX From Module (TX TI Eval Board) – 3.3V Logic Level
10	NC	NC	Not Connected
11	NC	NC	Not Connected
12	NC	NC	Not Connected
13	NC	NC	Not Connected
14	BOOT ENABLE	DIO	Module Boot Enable (Active Low) – 3.3V Logic Level
15	NC	NC	Not Connected
16	NC	NC	Not Connected
17	NC	NC	Not Connected
18	NC	NC	Not Connected
19	GROUND	GND	Ground
20	NC	NC	Not Connected

**Table 15 J1 Signals**



J2 Pin Number	Pin Name	Module Pin Type	Description
1	JTAG TCKC	DIO	cJTAG TCK
2	GROUND	GND	Ground
3	NC	NC	Not Connected
4	JTAG TMS	DIO	cJTAG TMS
5	NC	NC	Not Connected
6	NC	NC	Not Connected
7	GROUND	GND	Ground
8	GROUND	GND	Ground
9	UART RX	DIO	RX From Module (TX TI Eval Board) – TI Logic Level
10	NC	NC	Not Connected
11	NC	NC	Not Connected
12	NC	NC	Not Connected
13	NC	NC	Not Connected
14	NC	NC	Not Connected
15	RESET n	DIO	Module Reset (Active Low) – 3.3V Logic Level
16	NC	NC	Not Connected
17	NC	NC	Not Connected
18	NC	NC	Not Connected
19	NC	NC	Not Connected
20	NC	NC	Not Connected

**Table 16 J2 Signals**

5.1.6 TI EM Adapter Board Schematic

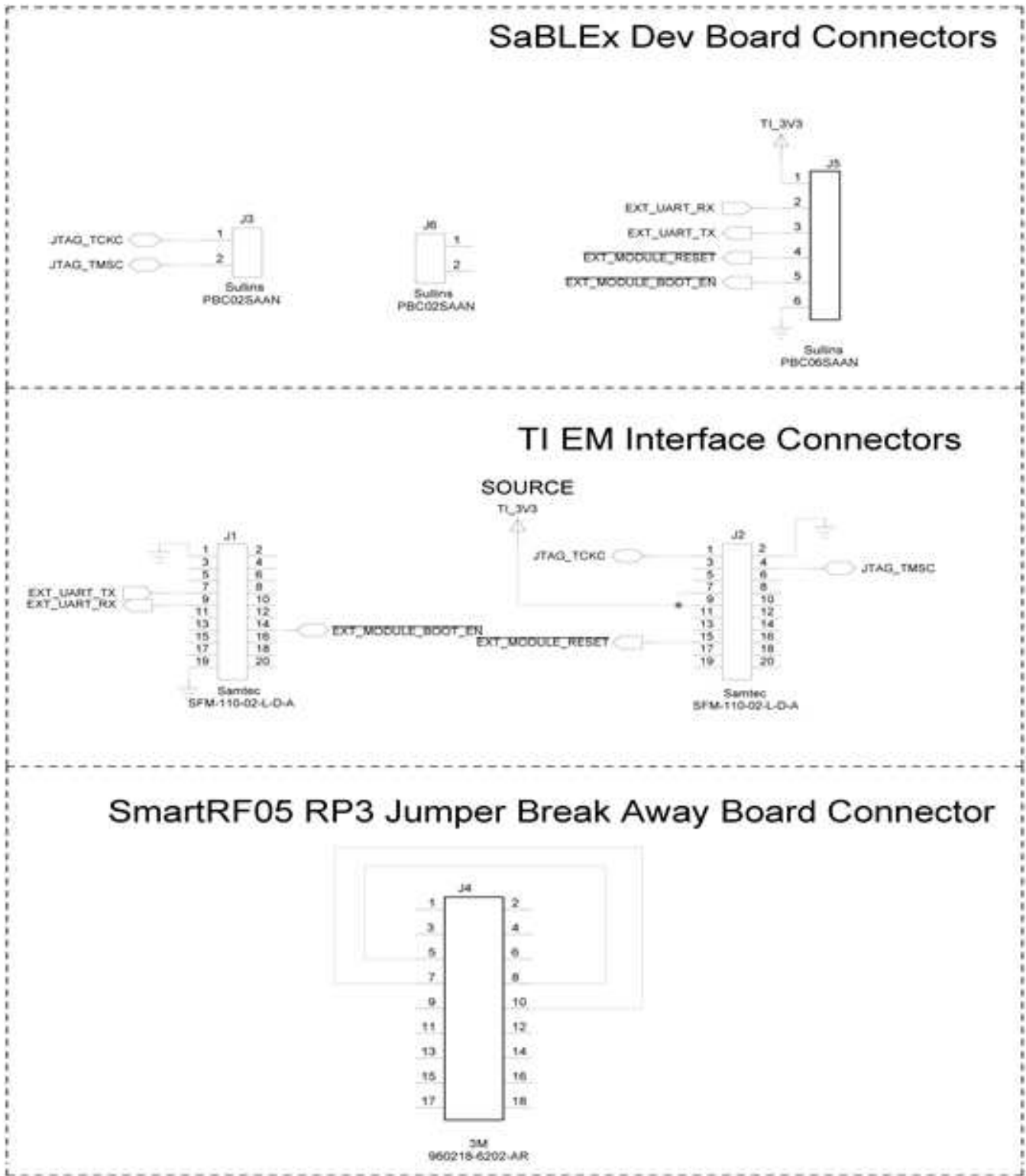

Figure 14 SaBLE-x Development Board to TI Adapter Schematic