



Chipsmall Limited consists of a professional team with an average of over 10 year of expertise in the distribution of electronic components. Based in Hongkong, we have already established firm and mutual-benefit business relationships with customers from,Europe,America and south Asia,supplying obsolete and hard-to-find components to meet their specific needs.

With the principle of "Quality Parts,Customers Priority,Honest Operation,and Considerate Service",our business mainly focus on the distribution of electronic components. Line cards we deal with include Microchip,ALPS,ROHM,Xilinx,Pulse,ON,Everlight and Freescale. Main products comprise IC,Modules,Potentiometer,IC Socket,Relay,Connector.Our parts cover such applications as commercial,industrial, and automotives areas.

We are looking forward to setting up business relationship with you and hope to provide you with the best service and solution. Let us make a better world for our industry!



## Contact us

Tel: +86-755-8981 8866 Fax: +86-755-8427 6832

Email & Skype: info@chipsmall.com Web: www.chipsmall.com

Address: A1208, Overseas Decoration Building, #122 Zhenhua RD., Futian, Shenzhen, China



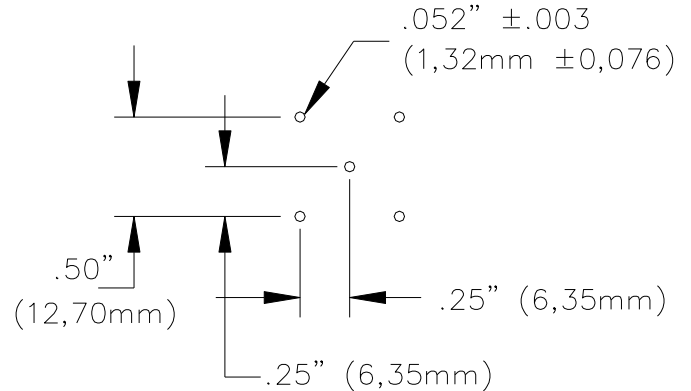
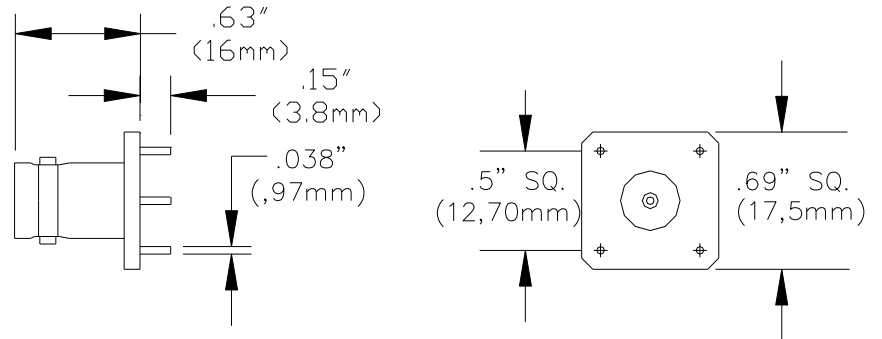

RECOMMENDED  
PC MOUNTING

**MATERIALS:**

- Body: Tarnish Resistant Nickel Plated Brass
- Body Mounting Pins: Nickel Plated Brass
- Center Contact: Gold Plated Beryllium Copper
- Center Mounting Pin: Gold Plated Brass
- Dielectric: Teflon per ASTM-D-1457

**RATINGS:**

- Operating Voltage: Hands free usage in controlled voltage environments: 500 Vrms maximum. *For CE compliance:* not intended for hand-held use at voltages above 33 Vrms/70 Vdc.
- Operating Temperature: -85°F to +329° F (-65°C to +165°C).
- Nominal Impedance: 50 Ohms

**ORDERING INFORMATION:** Model 4578

All dimensions are in inches. Tolerances (except noted): .xx = ±.02" (.51 mm), .xxx = ± .005" (.127 mm).  
 All specifications are to the latest revisions. Specifications are subject to change without notice.  
 Registered trademarks are the property of their respective companies.