



Chipsmall Limited consists of a professional team with an average of over 10 year of expertise in the distribution of electronic components. Based in Hongkong, we have already established firm and mutual-benefit business relationships with customers from,Europe,America and south Asia,supplying obsolete and hard-to-find components to meet their specific needs.

With the principle of “Quality Parts,Customers Priority,Honest Operation,and Considerate Service”,our business mainly focus on the distribution of electronic components. Line cards we deal with include Microchip,ALPS,ROHM,Xilinx,Pulse,ON,Everlight and Freescale. Main products comprise IC,Modules,Potentiometer,IC Socket,Relay,Connector.Our parts cover such applications as commercial,industrial, and automotives areas.

We are looking forward to setting up business relationship with you and hope to provide you with the best service and solution. Let us make a better world for our industry!



Contact us

Tel: +86-755-8981 8866 Fax: +86-755-8427 6832

Email & Skype: info@chipsmall.com Web: www.chipsmall.com

Address: A1208, Overseas Decoration Building, #122 Zhenhua RD., Futian, Shenzhen, China





The engineer's choice

ebmpapst

4606 ZWU-879

INDEX

1 General..... 3

2 Mechanics..... 3

2.1 GENERAL 3

2.2 CONNECTIONS..... 4

3 Operating Data 5

3.1 ELECTRICAL OPERATING DATA..... 5

3.2 OPERATING DATA - ELECTRICAL INTERFACE -OUTPUT 6

3.3 ELECTRICAL FEATURES 6

3.4 AERODYNAMIC 6

3.5 SOUND DATA 7

4 Environment 8

4.1 GENERAL 8

4.2 CLIMATIC REQUIREMENTS*)..... 8

5 Safety 9

5.1 ELECTRICAL SAFETY..... 9

5.2 APPROVAL TESTS..... 9

6 Reliability 9

6.1 GENERAL 9

1 General

| | |
|---------------------------------------|------------------------|
| Fan type | Fan |
| Rotational direction looking at rotor | clockwise |
| Airflow direction | Air outlet over struts |
| Bearing system | Ball bearing |
| Mounting position | any |
| Balancing grade | 2,5 |

2 Mechanics**2.1 General**

| | | |
|---|---|--|
| Width | 119,0 mm | |
| Height | 119,0 mm | |
| Depth | 38,0 mm | |
| Diameter | 0,0 mm | |
| Weight | 0,540 kg | |
| Housing material | Metal | |
| Impeller material | Metal | |
| Max. torque when mounted across both mounting flanges | wire outlet corner: 120 Ncm remaining corners: 350 Ncm | |
| Screw size | ISO 4762 - M4 degreased, without an additional brace and without washer | |

2.2 Connections

| | | |
|-----------------------|--------------|--|
| Electrical connection | Wires | |
| Length of lead wire | L = 770,0 mm | |
| Tolerance | +/- 10,0 mm | |
| Length of tube | see drawing | |
| Tolerance | | |
| Wire gauge (AWG) | 20 | |
| Insulation diameter | 1,77 mm | |
| Plug | see drawing | |
| Contact | see drawing | |

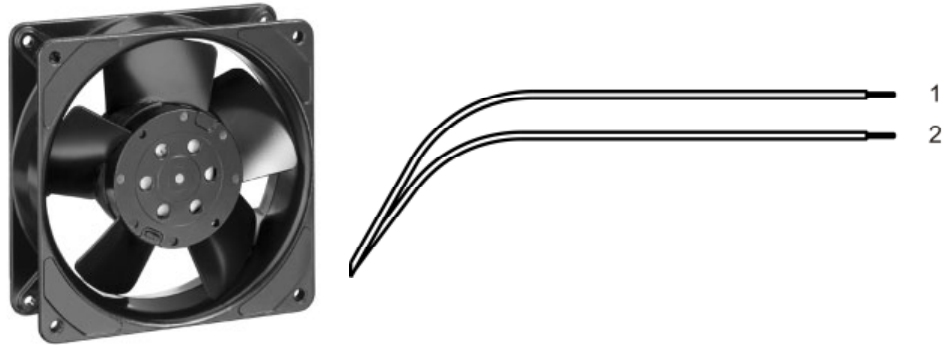

| | Colour | Operation |
|--------|--------|-----------|
| Wire 1 | white | L |
| Wire 2 | white | N |

3 Operating Data

3.1 Electrical Operating Data

Measurement conditions: Normal air density = 1,2 kg/m³; Temperature 23°C +/- 3°C; Motor axis horizontal; warm-up time before measuring 5 minutes (unless otherwise specified).
In the intake and outlet area should not be any solid obstruction within 0,5 m.

$\Delta p = 0$: corresp. to free air flow (see section 3.4)

I: corresp. to RMS line current

| Features | Condition | Symbol | Values | |
|--------------------------------|----------------|--------|--------------------------|--------------------------|
| Frequency | $\Delta p = 0$ | f | 50 Hz | 60 Hz |
| Nominal voltage Tolerance | $\Delta p = 0$ | U_N | 115,0 V +/- 10,0 % | 115,0 V +/- 10,0 % |
| Power consumption Tolerance | $\Delta p = 0$ | P | 19,0 W +/- 10,0 % | 17,0 W +/- 10,0 % |
| Speed Tolerance | $\Delta p = 0$ | n | 2.650 1/min +/- 3,0 % | 3.100 1/min +/- 3,0 % |

3.2 Operating Data - Electrical Interface -Output

| | |
|------------|------|
| Tacho type | None |
|------------|------|

3.3 Electrical Features

| | |
|----------------------------|-----------|
| Locked rotor protection | Impedance |
| Locked rotor current at Un | |

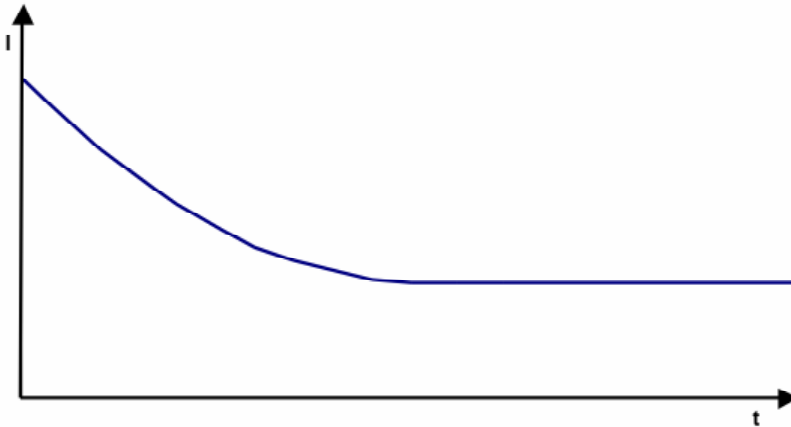

3.4 Aerodynamic

Measurement conditions: Measured with a double chamber intake rig acc. to DIN EN ISO 5801.
 Normal air density = 1,2 kg/m³; Temperature 23°C +/- 3°C;
 In the intake and outlet area should not be any solid obstruction within 0,5 m.
 The information is only valid under the specified test conditions and may be changed by the installation conditions. If there are deviations from the standard test conditions, the characteristic values must be checked under the installed conditions.

a.) Operation condition:
 2.650 1/min at free air flow Frequency: 50 Hz

| | |
|---|-------------------------|
| Max. free-air flow ($\Delta p = 0 / \dot{V} = \text{max.}$) | 152,0 m ³ /h |
| Max. static pressure ($\Delta p = \text{max.} / \dot{V} = 0$) | 70 Pa |

b.) Operation condition:
 3.100 1/min at free air flow Frequency: 60 Hz

| | |
|---|-------------------------|
| Max. free-air flow ($\Delta p = 0 / \dot{V} = \text{max.}$) | 180,0 m ³ /h |
| Max. static pressure ($\Delta p = \text{max.} / \dot{V} = 0$) | 80 Pa |

3.5 Sound Data

Measurement conditions: Sound pressure level: 1 Meter distance between microphone and the air intake.
 Sound power level: Acc. to DIN 45635 part 38 (ISO 10302)
 Measured in a semianchoic chamber with a background noise level of $L_p(A) < 5 \text{ dB(A)}$
 For further measurement conditions see section 3.4

a.) Operation condition:

2.650 1/min at free air flow

Frequency: 50 Hz

| | | |
|---|---------------------------------|--|
| Optimal operating point | 130,0 m ³ /h @ 15 Pa | |
| Sound power level at the optimal operating point | 5,1 bel(A) | |
| Sound pressure level at free air flow, measured in rubber bands | 37,0 dB(A) | |

b.) Operation condition:

3.100 1/min at free air flow

Frequency: 60 Hz

| | | |
|---|---------------------------------|--|
| Optimal operating point | 148,0 m ³ /h @ 20 Pa | |
| Sound power level at the optimal operating point | 5,5 bel(A) | |
| Sound pressure level at free air flow, measured in rubber bands | 42,0 dB(A) | |

4 Environment

4.1 General

| | | |
|--|----------------------------------|--|
| Min. permitted ambient temperature TU min. | -40 °C / 50 Hz -40 °C / 60 Hz | |
| Max. permitted ambient temperature TU max. | 70 °C / 50 Hz 80 °C / 60 Hz | |
| Min. permitted storage temperature TL min. | -40 °C | |
| Max. permitted storage temperature TL max. | 100 °C | |

4.2 Climatic requirements *)

| | | |
|--------------------------------|---|--|
| IP-protection type (certified) | IP 55 **) | |
| Humidity requirements | humid temperature, cyclic; according to DIN EN 60068-2-38, 10 cycle and condensation water check; according to DIN EN ISO 6270-2, 14 days | |
| Salt fog requirements | None | |

*) Permitted application area:

The product is for the use in partial sheltered rooms or open, roofed areas. Direct exposure to water is allowed provided that this does not prevent the normal operation. Saline ambient conditions must be avoided.

Pollution degree 3 (according DIN EN 60664-1)

It occurs conductive pollution or dry non-conductive pollution which becomes conductive due to condensation.

***) The specification of the IP protection refers to the conditions mentioned in certification of the fan. The above mentioned short description of the protection scope is not final. For detailed information of the respective protection scope and definitions, see certification as well as DIN EN 60529 (protection by housings) and ISO 20653 (for vehicles) with the letter K.

Short description of the IP-protection type:

Solid particle Protection: Protected against dust.

Protection against deliberate contact: Protected against contact to hazardous parts with a wire.

Protection against water: Protected against water jets.

5 Safety

5.1 Electrical Safety

| | |
|---|--|
| Dielectric strength DIN EN 60950 (VDE 0805) and DIN EN 60335 (VDE 0700) A.) Type test Measuring conditions: After 48h of storage at 95% R.H. and 25°C. No arcing or breakdown is allowed! All connections together to ground. B.) Routine test Measuring conditions: At indoor climate. No arcing or breakdown is allowed! All connections together to ground. | 1000 VAC / 1 Min. 1500 VAC / 1 Sec. |
| Isolation resistance Measuring conditions: After 48h of storage at 95% R.H. and 25°C measured with U=500 VDC for 1 min. | RI > 50 MOhm |
| clearance / creepage distance | 2,0 mm / 1,1 mm |
| Protection class | I |

5.2 Approval Tests

| | |
|-----|---|
| CE | Yes |
| UL | Yes / UL507, Electric Fans |
| VDE | Yes / Approval acc. to EN 60950 (VDE 0805) - Information technology equipment |
| CSA | Yes / C22.2 No. 113 Fans and Ventilators |
| CCC | Yes / GB 12350 Safety Requirements for small Power Motors |

The approval tests are observed to:

U approval max.: 115 V / f: 60 Hz @ TU approval max.: 85 °C

6 Reliability

6.1 General

| | | |
|-----------------------------------|------------------|--|
| Life expectancy L10 at TU = 40 °C | 37.500 h / 50 Hz | |
| Life expectancy L10 at TU max. | 17.500 h / 50 Hz | |

Copying of this document, analyzing it to others and the use or communication of the contents thereof, are prohibited. The copyright and all other rights are reserved in favour of the manufacturer and the manufacturer of a third party or design.

Schweißmaß nach DIN EN ISO 9005 beachten/
 Rule to production metric DIN ISO 9005

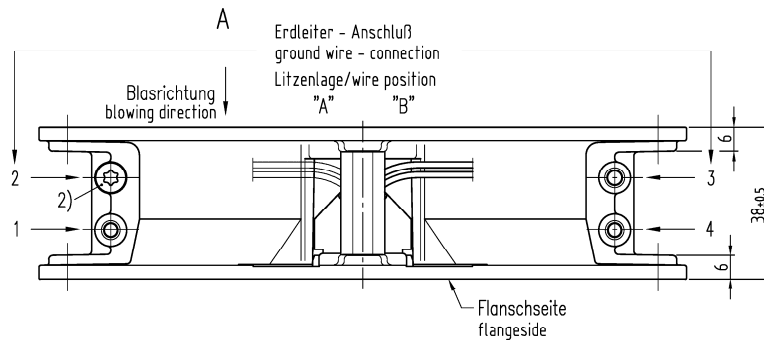
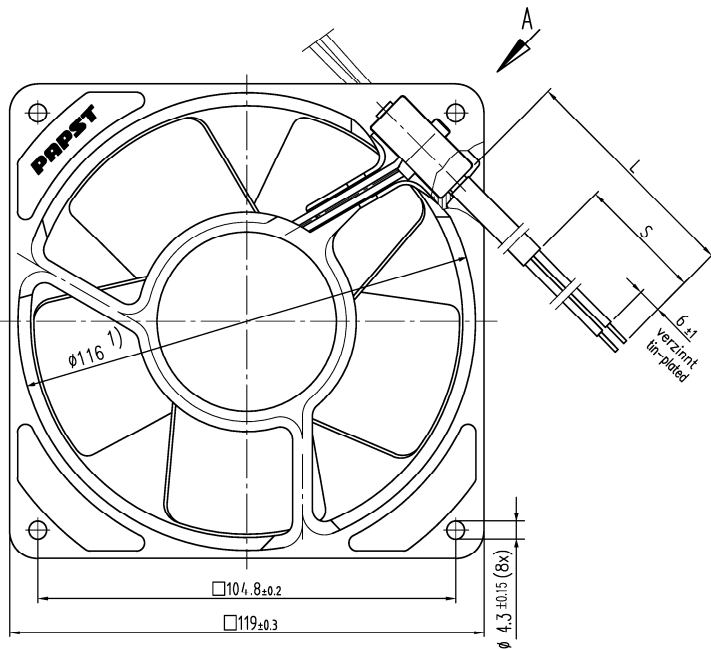

Anzahl und Länge der Litzen sowie
 Schlauchlänge, Litzenlage und Erdleiter-Anschluß s. Spezifikation
 length and number of wires and of tube length,
 wires length and ground wire -connection see design specification

1) Maße für Montagewand
 2) Schraube: Duo-Tapfite nach DIN 7500,
 CM 4x8, Torx

1) dimensions for assembly wall
 2) Screw: Duo-Tapfite to DIN 7500,
 CM 4x8, Torx

Axialspiel bei
 - Kugellagerung (K): 0 (mit Federausgleich)
 - Gleitlagerung (G): 0.1 - 0.6
 - Gleitlagerung (GF): 0 (mit Federausgleich)

axial clearance by
 - ball bearing (K): 0 (with spring compensation)
 - sleeve bearing (G): 0.1 - 0.6
 - sleeve bearing (GF): 0 (with spring compensation)

| | | | | | | | |
|-------------------------------------|-----------------------|-----------------------|----------------------------------|------------------------------|--|------------------------------------|--|
| | | ebmpapst | | Werkstoff/Material: | | Volumen/Volume (mm ³): | |
| SAP-Status/State | Artid.-Nr./Charge-No. | AutCAD-System-Version | CAD-Umgebung/ CAD-Environment | | | Gewicht/Mass (g): | |
| | | Datum/Date | | Name/Name | | | |
| | | Bearb./ Drawn | | | | Artikel/Title | |
| Tolerierung/Tolerances | | Gepr./ Checked | | | | | |
| Allgemeintoleranzen/Gen. Tolerances | | Freig./ Released | | | | | |
| ebmpapst | | | | Zchg.-Nr. / Drawing-No.: | | Ers. / Zchg. / Replaces: | |
| ebm-papst St. Georgen GmbH & Co. KG | | | | Dokumenttyp/Type of Document | | Format/Size | |
| | | | | Teildokument Blatt/Page | | Index/Index | |
| | | | | Formel/Size | | Maßstab/Scale | |