



Chipsmall Limited consists of a professional team with an average of over 10 year of expertise in the distribution of electronic components. Based in Hongkong, we have already established firm and mutual-benefit business relationships with customers from,Europe,America and south Asia,supplying obsolete and hard-to-find components to meet their specific needs.

With the principle of “Quality Parts,Customers Priority,Honest Operation,and Considerate Service”,our business mainly focus on the distribution of electronic components. Line cards we deal with include Microchip,ALPS,ROHM,Xilinx,Pulse,ON,Everlight and Freescale. Main products comprise IC,Modules,Potentiometer,IC Socket,Relay,Connector.Our parts cover such applications as commercial,industrial, and automotives areas.

We are looking forward to setting up business relationship with you and hope to provide you with the best service and solution. Let us make a better world for our industry!



Contact us

Tel: +86-755-8981 8866 Fax: +86-755-8427 6832

Email & Skype: info@chipsmall.com Web: www.chipsmall.com

Address: A1208, Overseas Decoration Building, #122 Zhenhua RD., Futian, Shenzhen, China





The engineer's choice

ebmpapst

4658 N

INDEX

1	General	3
2	Mechanics	3
2.1	GENERAL	3
2.2	CONNECTIONS.....	4
3	Operating Data	5
3.1	ELECTRICAL OPERATING DATA.....	5
3.2	OPERATING DATA - ELECTRICAL INTERFACE -OUTPUT.....	5
3.3	ELECTRICAL FEATURES.....	5
3.4	AERODYNAMIC.....	6
3.5	SOUND DATA.....	7
4	Environment	8
4.1	GENERAL	8
4.2	CLIMATIC REQUIREMENTS*).....	8
5	Safety	9
5.1	ELECTRICAL SAFETY.....	9
5.2	APPROVAL TESTS	9
6	Reliability	9
6.1	GENERAL	9

1 General

Fan type	Fan
Rotational direction looking at rotor	clockwise
Airflow direction	Air intake over struts
Bearing system	Ball bearing
Mounting position	any
Balancing grade	2,5

2 Mechanics**2.1 General**

Width	119,0 mm	
Height	119,0 mm	
Depth	38,0 mm	
Diameter	0,0 mm	
Weight	0,550 kg	
Housing material	Metal	
Impeller material	Metal	
Max. torque when mounted across both mounting flanges	wire outlet corner: 190 Ncm remaining corners: 310 Ncm	
Screw size	ISO 4762 - M4 degreased, without an additional brace and without washer	

2.2 Connections

Electrical connection	Plug	
Length of lead wire	see drawing	
Tolerance		
Length of tube	see drawing	
Tolerance		
Wire gauge (AWG)		
Insulation diameter		
Plug	see drawing	
Contact	see drawing	

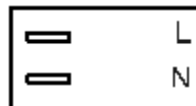

3 Operating Data

3.1 Electrical Operating Data

Measurement conditions: Normal air density = 1,2 kg/m³; Temperature 23°C +/- 3°C; Motor axis horizontal; warm-up time before measuring 5 minutes (unless otherwise specified).
In the intake and outlet area should not be any solid obstruction within 0,5 m.

$\Delta p = 0$: corresp. to free air flow (see section 3.4)

I: corresp. to RMS line current

Features	Condition	Symbol	Values	
Frequency	$\Delta p = 0$	f	50 Hz	60 Hz
Nominal voltage	$\Delta p = 0$	U_N	230,0 V	230,0 V
Tolerance			+ 6,0 % - 10,0 %	+ 6,0 % - 10,0 %
Power consumption	$\Delta p = 0$	P	19,5 W	18,0 W
Tolerance			+ 5,0 % - 10,0 %	+ 5,0 % - 10,0 %
Speed	$\Delta p = 0$	n	2.600 1/min	2.950 1/min
Tolerance			+/- 3,0 %	+/- 3,0 %

3.2 Operating Data - Electrical Interface -Output

Tacho type	None
------------	------

3.3 Electrical Features

Locked rotor protection	Impedance
Locked rotor current at U_N	

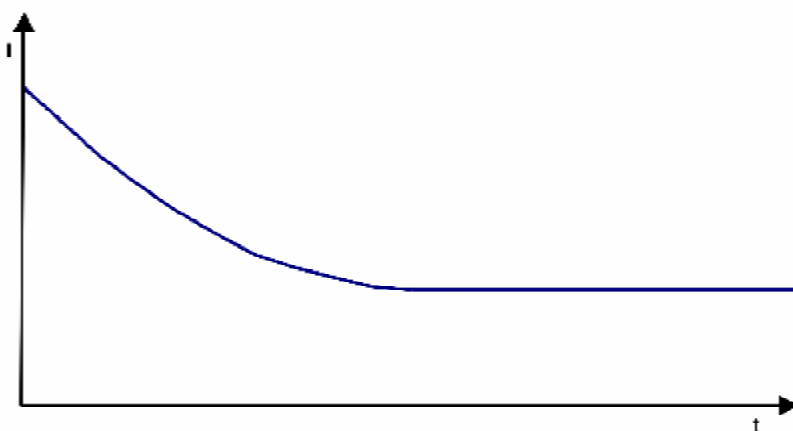

3.4 Aerodynamic

Measurement conditions: Measured with a double chamber intake rig acc. to DIN EN ISO 5801. Normal air density = 1,2 kg/m³; Temperature 23°C +/- 3°C; In the intake and outlet area should not be any solid obstruction within 0,5 m. The information is only valid under the specified test conditions and may be changed by the installation conditions. If there are deviations from the standard test conditions, the characteristic values must be checked under the installed conditions.

a.) Operation condition:
2.600 1/min at free air flow Frequency: 50 Hz

Max. free-air flow ($\Delta p = 0 / \dot{V} = \text{max.}$)	146,0 m ³ /h
Max. static pressure ($\Delta p = \text{max.} / \dot{V} = 0$)	78 Pa

b.) Operation condition:
2.950 1/min at free air flow Frequency: 60 Hz

Max. free-air flow ($\Delta p = 0 / \dot{V} = \text{max.}$)	170,0 m ³ /h
Max. static pressure ($\Delta p = \text{max.} / \dot{V} = 0$)	90 Pa

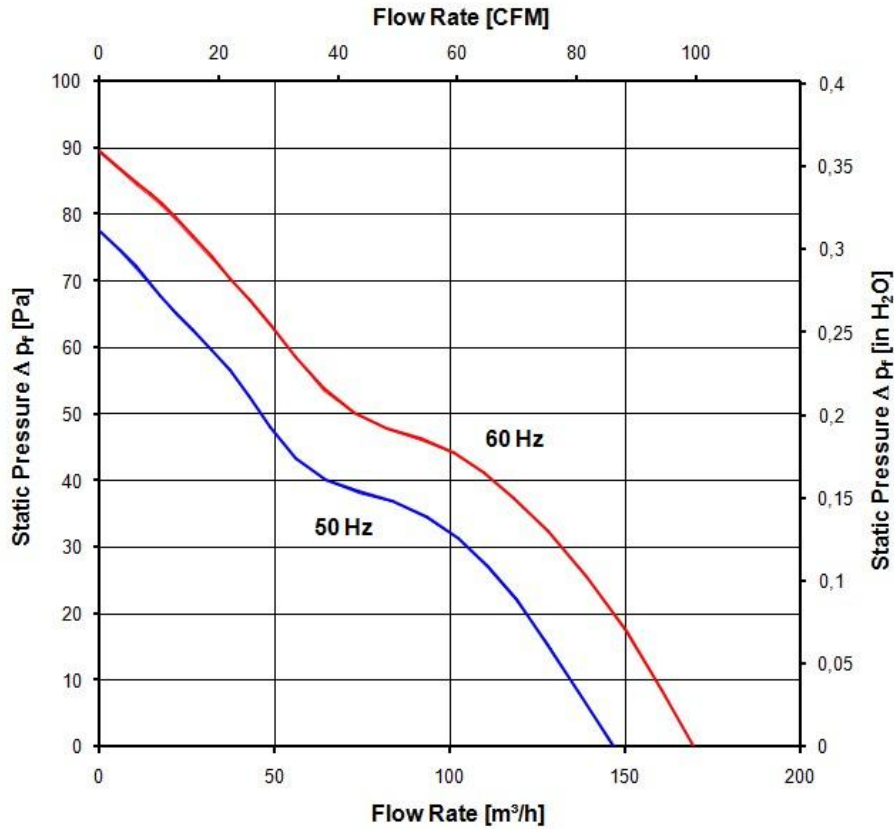

3.5 Sound Data

Measurement conditions: Sound pressure level: 1 Meter distance between microphone and the air intake.
 Sound power level: Acc. to DIN 45635 part 38 (ISO 10302)
 Measured in a semianchoic chamber with a background noise level of $L_p(A) < 5 \text{ dB(A)}$
 For further measurement conditions see section 3.4

a.) Operation condition:

2.600 1/min at free air flow

Frequency: 50 Hz

Optimal operating point	110,0 m ³ /h @ 25 Pa	
Sound power level at the optimal operating point	5,4 bel(A)	
Sound pressure level at free air flow, measured in rubber bands	44,0 dB(A)	

b.) Operation condition:

2.950 1/min at free air flow

Frequency: 60 Hz

Optimal operating point	120,0 m ³ /h @ 31 Pa	
Sound power level at the optimal operating point	5,7 bel(A)	
Sound pressure level at free air flow, measured in rubber bands	48,0 dB(A)	

4 Environment

4.1 General

Min. permitted ambient temperature TU min.	-40 °C / 50 Hz -40 °C / 60 Hz	
Max. permitted ambient temperature TU max.	85 °C / 50 Hz 90 °C / 60 Hz	
Min. permitted storage temperature TL min.	-40 °C	
Max. permitted storage temperature TL max.	100 °C	

4.2 Climatic requirements *)

Humidity requirements	humid heat, constant; according to DIN EN 60068-2-78, 14 days	
Water exposure	None	
Radiation exposure	None	
Dust requirements	None	
Salt fog requirements	None	
Harmful gas requirements	None	

*) Permitted application area:

The product is intended for use in sheltered rooms with controlled temperature and controlled humidity. Directly exposure to water must be avoided.

Pollution degree 1 (according DIN EN 60664-1)

There is either no pollution or it occurs only dry, non-conductive pollution. The pollution has no negative impact.

5 Safety

5.1 Electrical Safety

Dielectric strength DIN EN 60950 (VDE 0805) and DIN EN 60335 (VDE 0700) A.) Type test Measuring conditions: After 48h of storage at 95% R.H. and 25°C. No arcing or breakdown is allowed! All connections together to ground. B.) Routine test Measuring conditions: At indoor climate. No arcing or breakdown is allowed! All connections together to ground.	1500 VAC / 1 Min. 1500 VAC / 1 Sec.
Isolation resistance Measuring conditions: After 48h of storage at 95% R.H. and 25°C measured with U=500 VDC for 1 min.	RI > 50 MOhm
clearance / creepage distance	2,0 mm / 1,8 mm
Protection class	I

5.2 Approval Tests

CE	Yes
UL	Yes / UL507, Electric Fans
VDE	Yes
CSA	Yes / C22.2 No. 113 Fans and Ventilators
CCC	Yes / GB 12350 Safety Requirements for small Power Motors

The approval tests are observed to:

U approval max.: 230 V / f: 60 Hz @ TU approval max.: 90 °C

6 Reliability

6.1 General

Life expectancy L10 at TU = 40 °C	37.500 h / 50 Hz 40.000 h / 60 Hz	
Life expectancy L10 at TU max.	15.000 h / 50 Hz 15.000 h / 60 Hz	

Copying of this document and giving it to others and the use or communication of its contents, however, are prohibited. The copyright holder is reserved. All rights are reserved. In the event of the print or reproduction of a copy, the text or design must be approved by the copyright holder.

Speichermaß nach DIN ISO 1800 beachten!
Refer to protection within the ISO 1800!

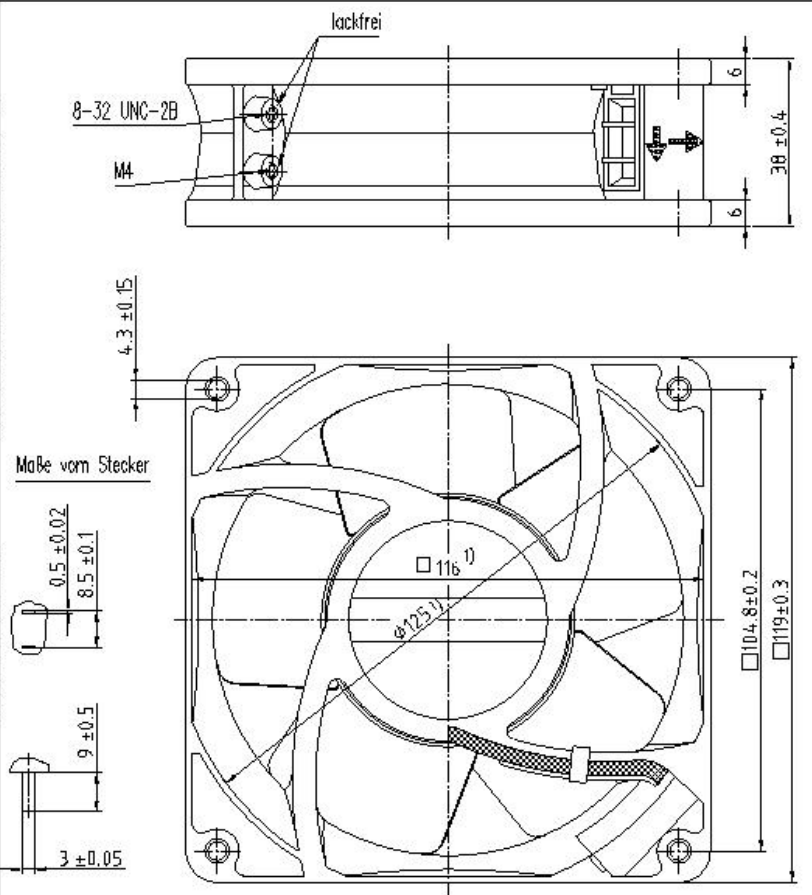

1) Maße für Montagewand

Axialspiel : mit Feder spielfrei verspannt

Tolerierung/Tolerances: DIN 7167
Allgemeintoleranzen/
Gen. tolerances: DIN ISO 2768-1u.2-mK

Datum/Date		Name/Name			Artikel/Title	Maßstab/Scale
Bearb./Drawn:						
Index/Index		Änd.-Nr./Change-No.			Zchg.-Nr./ Dwg.-No.:	Blatt/Page
für die Verwendung freigegeben/Checked for release von by		ebm-papst St. Georgen GmbH & Co. KG			Ers./Zchg./ Replaces:	