



Chipsmall Limited consists of a professional team with an average of over 10 year of expertise in the distribution of electronic components. Based in Hongkong, we have already established firm and mutual-benefit business relationships with customers from,Europe,America and south Asia,supplying obsolete and hard-to-find components to meet their specific needs.

With the principle of "Quality Parts,Customers Priority,Honest Operation,and Considerate Service",our business mainly focus on the distribution of electronic components. Line cards we deal with include Microchip,ALPS,ROHM,Xilinx,Pulse,ON,Everlight and Freescale. Main products comprise IC,Modules,Potentiometer,IC Socket,Relay,Connector.Our parts cover such applications as commercial,industrial, and automotives areas.

We are looking forward to setting up business relationship with you and hope to provide you with the best service and solution. Let us make a better world for our industry!



## Contact us

Tel: +86-755-8981 8866 Fax: +86-755-8427 6832

Email & Skype: info@chipsmall.com Web: www.chipsmall.com

Address: A1208, Overseas Decoration Building, #122 Zhenhua RD., Futian, Shenzhen, China



MARKETING SALES DRAWING

DIMENSIONS IN INCHES - DO NOT SCALE THIS DRAWING  
 DIMENSIONS IN METRIC [ ]

Electrical Testing  
 per Tusonix standard  
 test plans and Mil-Std-202  
 Test Methods.

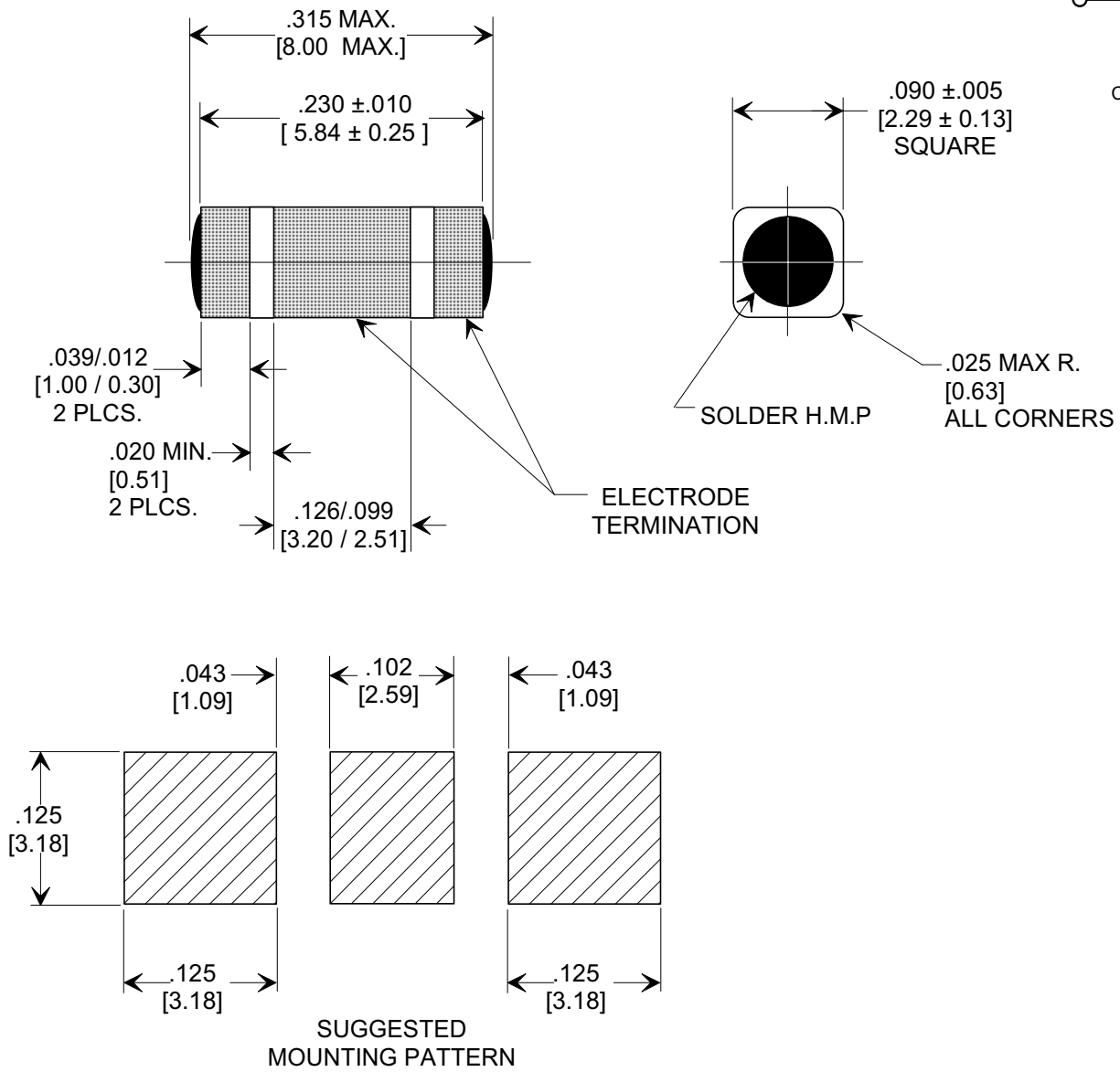
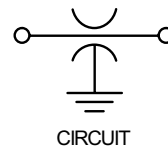
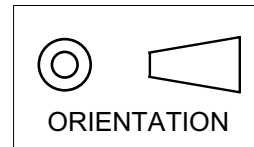

- NOTES:  
 1. INDUCTANCE TO BE 0.1 μH MINIMUM.  
 2. PACKAGE: BULK OR BLISTER TAPE TO IEC-60286-3 TYPE II AND EIA-481-A.

CAP.	TOLERANCE	WVDC		TEST VOLTAGE	IR MIN. @ 100 (VDC)	I <sub>DC</sub>	ELECTRODE TERMINATION	TYPICAL NO LOAD INSERTION LOSS dB AT 25°C PER MIL-STD-220		
		85°C	125°C					10 MHZ	100 MHZ	1 GHZ
100 pF	+80% / -20%	100	100	300 VDC	10 G Ω	20 A	SOLDER	----	1	19

REVISION RECORD	Original Release C.O.	0 WAS SK8060-STYLE. S.M. 04-22-02 20020418-4-06 RELOCATED MOUNTING PATTERN L.E. 07-09-02 1 20020709-2-01 ADDED INSERTION LOSS COLUMN. S.M. 04-07-03 2 20030407-1-01 REVISED DRAWING. S.M. 06-23-03 3 20030619-2-12	--TOLERANCES-- Unless Otherwise Specified	Title <b>SURFACE MOUNT SQUARE STYLE "C" FILTER 20 AMPS</b>		
	DECIMAL ± .005 [0.13]		Drawn L.E. 03-01-02		Scale 7 X	
	ANGLES ±		Approved B.M. 03-01-02		<b>A</b>	<b>4702-000</b>

X-2015 Rev-0