



Chipsmall Limited consists of a professional team with an average of over 10 year of expertise in the distribution of electronic components. Based in Hongkong, we have already established firm and mutual-benefit business relationships with customers from,Europe,America and south Asia,supplying obsolete and hard-to-find components to meet their specific needs.

With the principle of “Quality Parts,Customers Priority,Honest Operation,and Considerate Service”,our business mainly focus on the distribution of electronic components. Line cards we deal with include Microchip,ALPS,ROHM,Xilinx,Pulse,ON,Everlight and Freescale. Main products comprise IC,Modules,Potentiometer,IC Socket,Relay,Connector.Our parts cover such applications as commercial,industrial, and automotives areas.

We are looking forward to setting up business relationship with you and hope to provide you with the best service and solution. Let us make a better world for our industry!



## Contact us

Tel: +86-755-8981 8866 Fax: +86-755-8427 6832

Email & Skype: info@chipsmall.com Web: www.chipsmall.com

Address: A1208, Overseas Decoration Building, #122 Zhenhua RD., Futian, Shenzhen, China



## 47554 - Plastek™



### Description

- Increases productivity by organizing and standardizing bottle and tool placement at the workstation
- Aesthetically improves the appearance of the work area
- Includes openings for bottles, wipes and hand tools
- Includes ESD protective swab holder insert and cover for wipes
- OD Dimension: 16-7/8" x 8-1/8" x 2-3/8"
- Easily assembled
- Marked with ESD Protective symbol per ANSI/ESD S541
- Custom configurations available
- Conductive  $1 \times 10^2$  to  $< 1 \times 10^5$  ohms be per ANSI/ESD STM11.11
- Chemical and moisture resistant
- Economical alternative to injection molded products
- Made in the United States of America

### ASSEMBLY INSTRUCTIONS:

1. FOLD UP ORGANIZER TRAY
2. FOLD UP THE INSERT & PLACE IN TRAY
3. FOLD UP THE TALL SLEEVE AND WIPES LID AND PLACE IT INTO THE ORGANIZER INSERT AS SHOWN

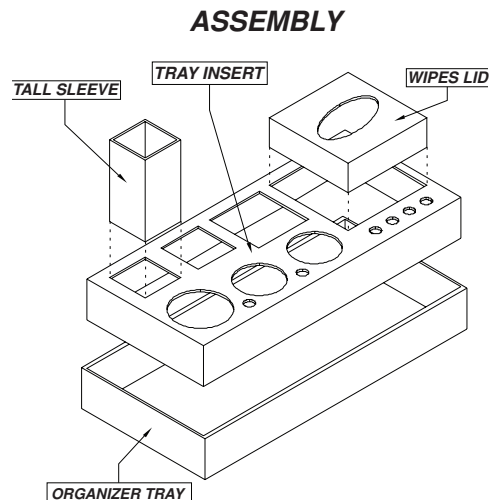

[47554](#) | Universal Organizer, Plastek™

A smaller organizer is available. Click [HERE](#) for item 47556.

"It should be understood that any object, item, material or person could be a source of static electricity in the work environment. Removal of unnecessary nonconductors, replacing nonconductive materials with dissipative or conductive materials and grounding all conductors are the principle methods of controlling static electricity in the workplace, regardless of the activity." [ESD Handbook ESD TR20.20 section 2.4 Sources of Static Electricity]



Made in the  
United States of America

Specifications and procedures subject to change without notice.

### Universal Organizer, Plastek™

**PROTEKTIVE PAK**  
13250 MONTE VISTA AVENUE, CHINO, CA 91710  
PHONE (909) 627-2578  
[ProtectivePak.com](http://ProtectivePak.com)

**DRAWING  
NUMBER**  
47554

**DATE:**  
March  
2013

# PROTEKTIVE PAK