



Chipsmall Limited consists of a professional team with an average of over 10 year of expertise in the distribution of electronic components. Based in Hongkong, we have already established firm and mutual-benefit business relationships with customers from,Europe,America and south Asia,supplying obsolete and hard-to-find components to meet their specific needs.

With the principle of “Quality Parts,Customers Priority,Honest Operation,and Considerate Service”,our business mainly focus on the distribution of electronic components. Line cards we deal with include Microchip,ALPS,ROHM,Xilinx,Pulse,ON,Everlight and Freescale. Main products comprise IC,Modules,Potentiometer,IC Socket,Relay,Connector.Our parts cover such applications as commercial,industrial, and automotives areas.

We are looking forward to setting up business relationship with you and hope to provide you with the best service and solution. Let us make a better world for our industry!



Contact us

Tel: +86-755-8981 8866 Fax: +86-755-8427 6832

Email & Skype: info@chipsmall.com Web: www.chipsmall.com

Address: A1208, Overseas Decoration Building, #122 Zhenhua RD., Futian, Shenzhen, China



1. INTRODUCTION

This instruction sheet provides "Instructions" on product application and a "Maintenance and Inspection Procedure" for:

SOLISTRAND* TERMINAL AND SPLICE CRIMPING DIES

47812 } 47813 }	Used in tool Nos. 46110, 69319-1, 69365, and 69710
47814 } 47814 Mod. H } 47815 }	Used in tool Nos. 46110, 69365, and 69710
69819 }	Used in tool Nos. 69365 and 69710

These dies are used to crimp:

- SOLISTRAND terminals and splices on wire range 22 thru 10.
- SOLISTRAND flag terminals on wire range 12 thru 10.

Basic instructions on the use of the dies, die insertion and removal, etc., are provided in Section 2 "Instructions." Section 3 features a terminal and splice "Crimp Inspection" procedure. Section 4 contains a "Maintenance and Inspection Procedure" which will enable you to establish and maintain a *die certification program*.

Dies are coated with preservative to prevent rust and corrosion. Wipe preservative from dies, particularly from crimping areas.

For further instructions relative to the air tools and hand tool, refer to instructions packaged with the tools.

2. INSTRUCTIONS

WARNING: AVOID PERSONAL INJURY. ALWAYS KEEP FINGERS CLEAR OF DIES WHEN OPERATING TOOLS.

2.1 DIE INSERTION

- Disconnect tool from air supply.
- Ensure that correct die, tool and terminal combination has been selected for the wire size being used. See Figure 1.
- Position stationary die in stationary die holder. Take up on die holding screw enough to hold die in place. Do not tighten screw. The stationary die is identified by the two chamfers on top of die. See Figure 2.
- Position moving die in moving die holder. Take up on die holding screw enough to hold die in place. Do not tighten screw. Be sure dies are oriented properly with each other.
- Connect air supply.
- Center terminal wire barrel in stationary die as shown in Figure 2 and activate tool to hold terminal in position.
- Insert stripped wire into terminal wire barrel. See Figure 1 for correct strip length.

All illustrations and information contained in this instruction sheet are based on the latest product information available at the time of publication.

Copyright 1957, 1968, 1974 by AMP Incorporated, Harrisburg, Pa. All International Rights Reserved. AMP Incorporated products covered by U.S. and Foreign Patents and/or Patents Pending.

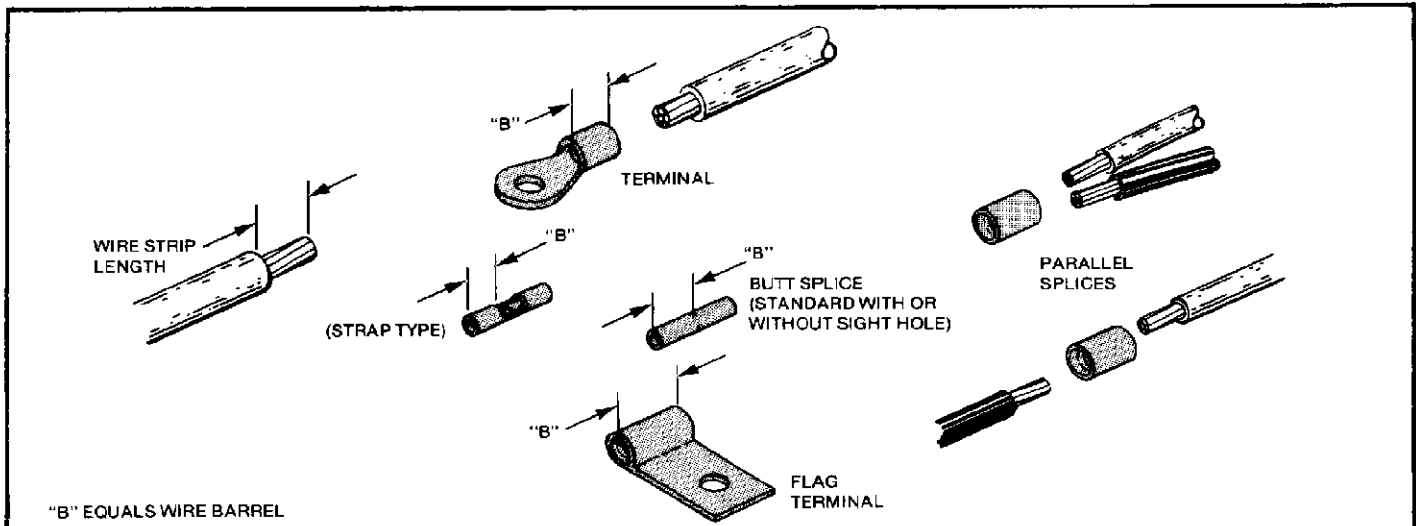

TOOL NO.	DIE NO.	WIRE RANGE	WIRE STRIP LENGTH							
			TERMINAL		FLAG TERMINAL		BUTT SPLICE		PARALLEL SPLICE	
			Min.	Max.	Min.	Max.	Min.	Max.	Min.	Max.
46110 † 69319-1 69365 69710	47812 47813	22-16 16-14	11/64"	13/64"	—	—	1/4"	9/32"	5/16"	11/32"
46110 69365 69710	47815 47814 47814 Mod. H	14-12 12-10	11/64"	13/64"	—	—	5/16"	11/32"	—	—
69365 69710	69819 ‡	12-10	—	—	11/32"	13/32"	—	—	—	—

Figure 1

† For terminals only

‡ For flag terminals only

- (h) Actuate tool to crimp terminal and hold dies at bottomed position.
- (i) With dies bottomed, tighten both die holding screws. Tool is now ready for operation.
IMPORTANT: CHECK DIE ALIGNMENT AND TIGHTEN DIE HOLDING SCREWS AT LEAST TWICE DAILY.

2.2 WIRE STRIPPING AND CRIMPING PROCEDURES

Strip wires to length specified in Figure 1.

NOTE: Do not use wires with nicked or missing strands.

2.2.1 Pneumatic Tools with Take-Up Feature

- (a) Connect air supply.
- (b) Center terminal or splice wire barrel in stationary die. For best results, when brazed seam on terminal or splice is visible, position seam toward moving die. See Figure 2. Center flag terminal wire barrel in stationary die. Hold flag terminal tongue against flat side of die. See Figure 3.

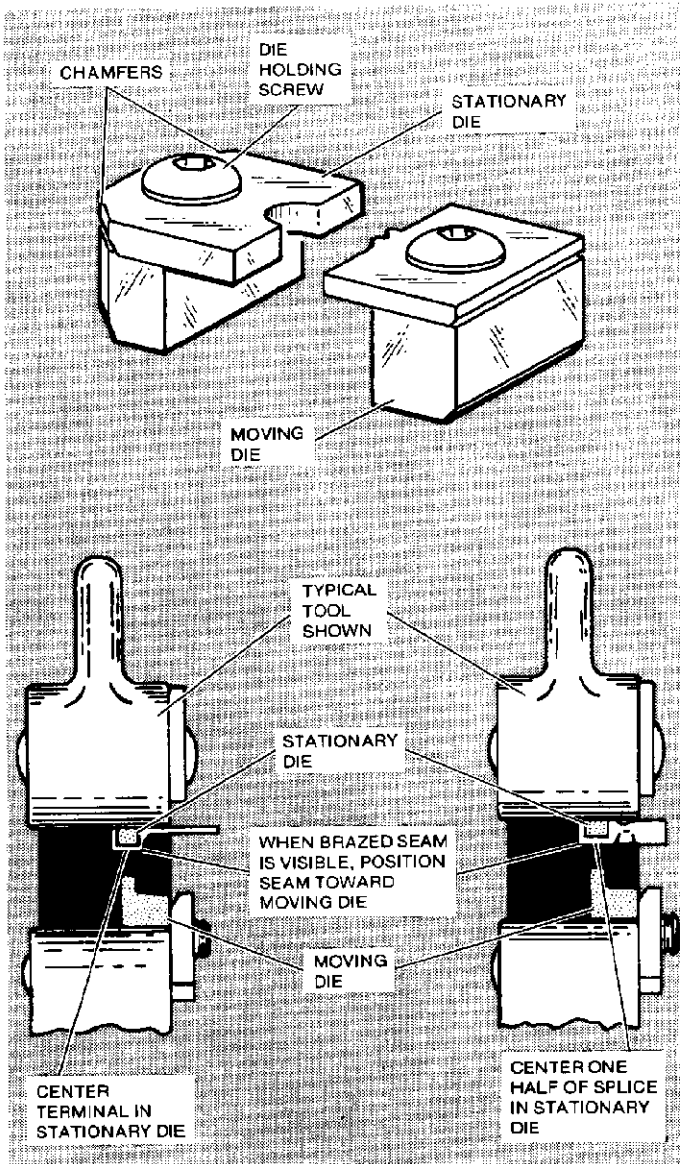

Figure 2

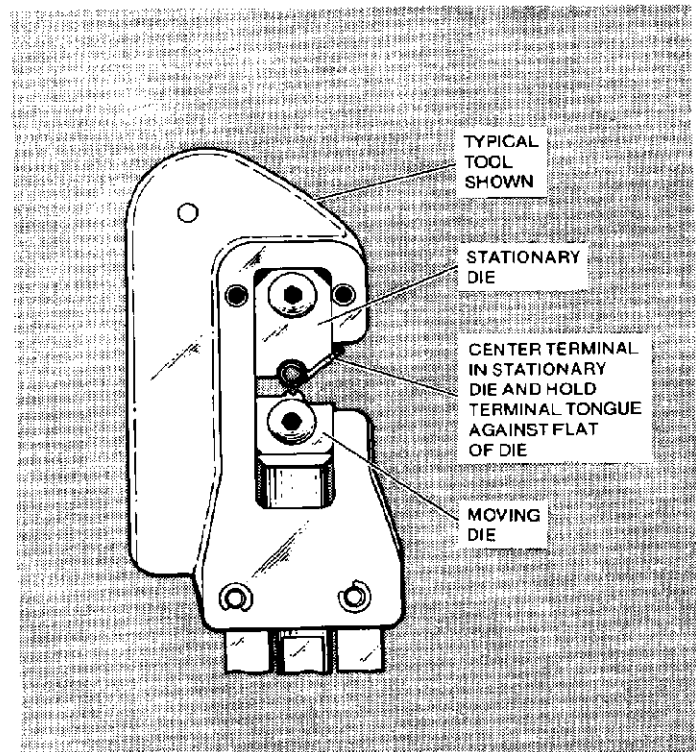

Figure 3

- (c) Actuate die take-up feature of tool until terminal, splice or flag terminal is held firmly in place.
- (d) Insert stripped wire into terminal, splice or flag terminal wire barrel.
- (e) Activate tool to complete the crimp and remove crimped item.
- (f) When crimping a butt splice, reposition uncrimped half in stationary die. Activate die take-up feature to hold splice firmly in place. Insert stripped wire and complete crimp.
- (g) Refer to Section 3 and Figure 4 for terminal or splice crimp inspection procedure.
NOTE: Terminal or splice positioning and crimping instructions are the same as steps (a) thru (f) of paragraph 2.2.1 when using pneumatic tools without die take-up feature.

2.2.2 Hand Tool

- (a) Center terminal or splice wire barrel in stationary die. For best results, when brazed seam on terminal or splice is visible, position seam toward moving die. See Figure 2. Center flag terminal wire barrel in stationary die. Hold flag terminal tongue against flat side of die. See Figure 3.
- (b) Close handles until terminal, splice or flag terminal is held firmly in place.
- (c) Insert stripped wire into terminal, splice or flag terminal wire barrel.
- (d) Complete crimp by closing handles until CERTI-CRIMP* ratchet releases.
- (e) Handles will open automatically and crimped item may be removed.
- (f) When crimping a butt splice, reposition uncrimped half in stationary die. Insert stripped wire and complete crimp.
- (g) Refer to Section 3 and Figure 4 for terminal or splice crimp inspection procedure.

3. CRIMP INSPECTION

Inspect crimped terminals and splices by checking the features described in Figure 4.

Use only the terminals and splices that meet the conditions shown in the "ACCEPT" column.

"REJECT" terminals and splices can be avoided through careful use of instructions in Section 2 and by performing regular die maintenance as instructed in Section 4.

4. MAINTENANCE/INSPECTION PROCEDURE

AMP recommends that a maintenance/inspection program be performed periodically to ensure dependable and uniform terminations. Dies should be

inspected at least once a month. Frequency of inspection may be adjusted to suit your requirements through experience. Frequency of inspection is dependent upon:

1. The care, amount of use, and handling of the dies.
2. The degree of operator skill.
3. The presence of abnormal amounts of dust and dirt.
4. Your own established standards.

All AMP* dies are thoroughly inspected before shipping. Since there is a possibility of die damage in shipment, new dies should be inspected in accordance with Section 4 when received in your plant.

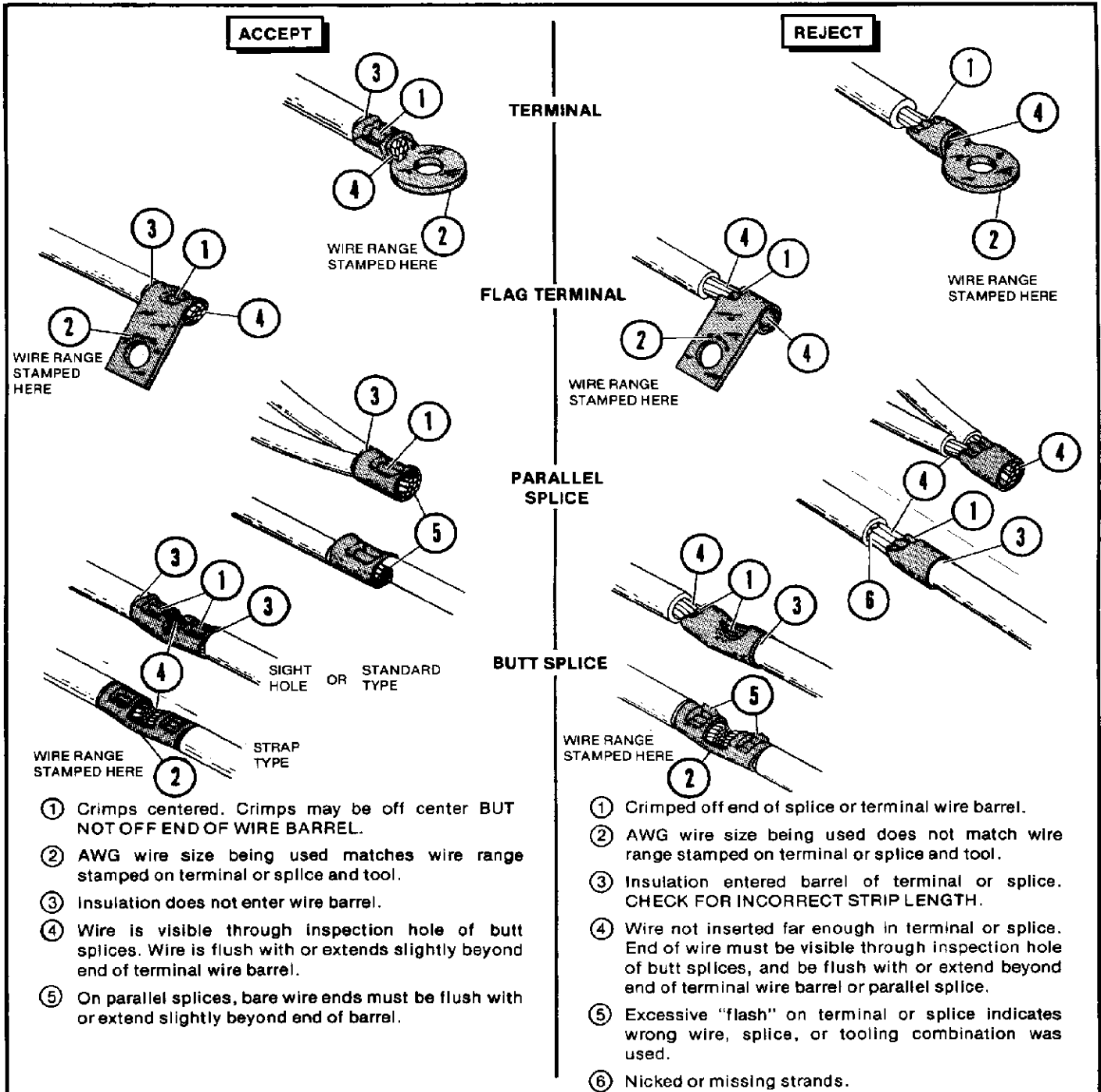

4.1 CLEANING

Do not allow deposits of dirt, grease and foreign matter to accumulate in the die closure area and on the bottoming surfaces of the dies. These deposits may prevent the dies from bottoming fully and may also cause excessive wear in the die closure surfaces, thereby affecting the quality of the crimp. The dies should be wiped clean frequently with a clean cloth.

4.2 VISUAL INSPECTION

Visually inspect the die closure surfaces for broken, chipped or pitted conditions. Although dies may gage within permissible limits, worn or damaged die closure surfaces are objectionable and can affect the quality of the crimp. Examples of possible damaged die surfaces are shown in Figure 5.

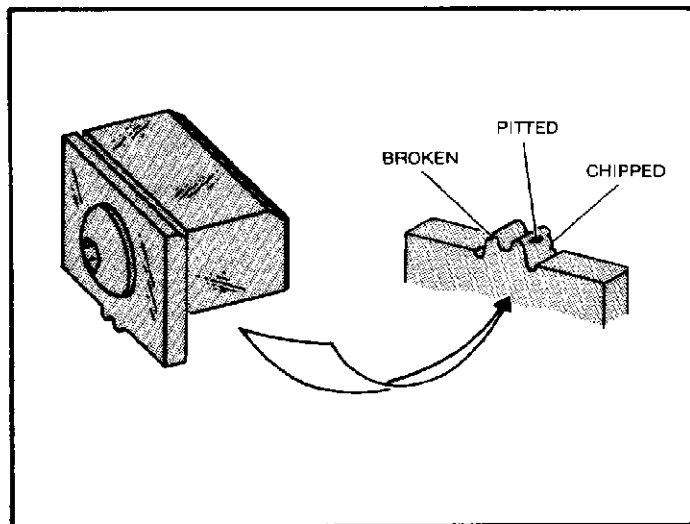

Figure 5

4.3 DIE CLOSURE INSPECTION

Every AMP die set is inspected and tested for proper die closure dimensions before shipping. An inspection should be performed periodically to check the die closure for excessive wear.

Die closure inspection is accomplished using GO NO-GO plug gages. AMP neither manufactures nor sells plug gages. A suggested plug gage design and the GO NO-GO dimensions of the plug gage members are listed in Figure 6.

The following procedure is recommended for inspecting the die closures.

- Clean oil or dirt from the die closure surfaces, bottoming surfaces, and plug gage members.
- Insert dies in tool.
- When using pneumatic tool, reduce air supply pressure to a range between 15-20 P.S.I. Actuate tool to bottom dies. When using hand tool, close handles of tool until dies bottom. Do not apply additional pressure to tool handles.
- With dies bottomed, inspect the die closure using the proper plug gage. Hold gage in straight alignment with the die closure as shown in Figure 7A and carefully try to insert without forcing, the GO member, and then the NO-GO member. See Figure 7B. The GO member must pass completely through the die closure. The NO-GO member may enter partially, but must not pass completely through the die closure.

- If dies meet GO NO-GO gage conditions, the dies are dimensionally correct.
- If dies do not meet the GO NO-GO gage conditions, contact your local AMP field representative.

4.4 REPLACEMENT PARTS

Die sets and die replacement parts, see Figure 8, can be purchased from AMP Incorporated, Harrisburg, Pa. 17105, or a wholly owned subsidiary of AMP Incorporated.

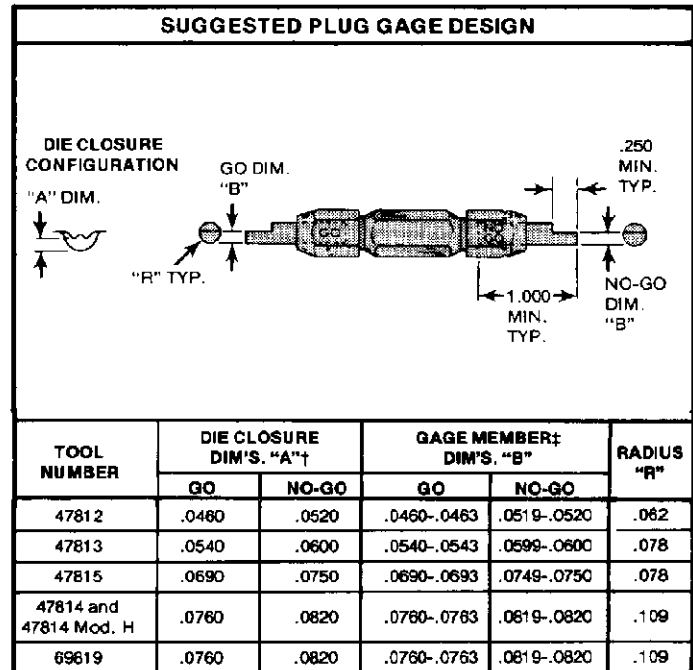

† Die closure dimensions apply when dies are bottomed but not under pressure.
‡ Material — Tool steel.

Figure 6

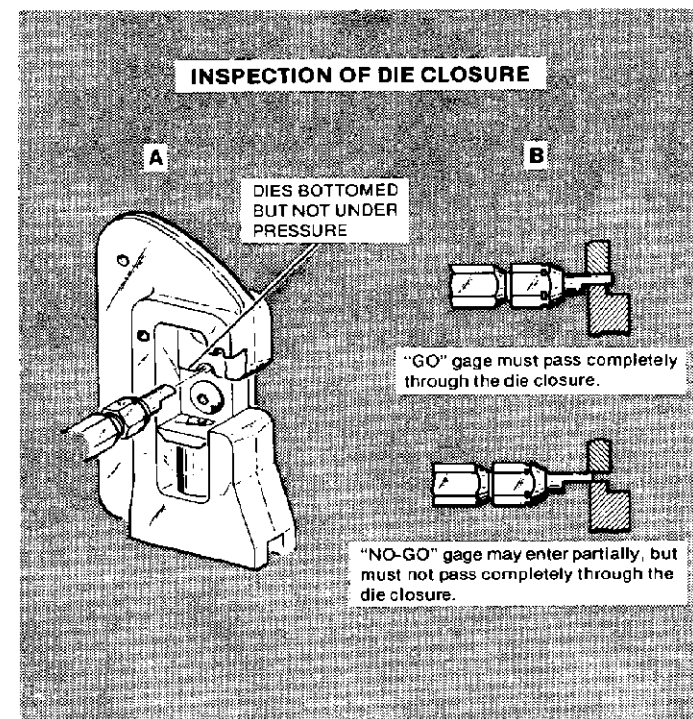
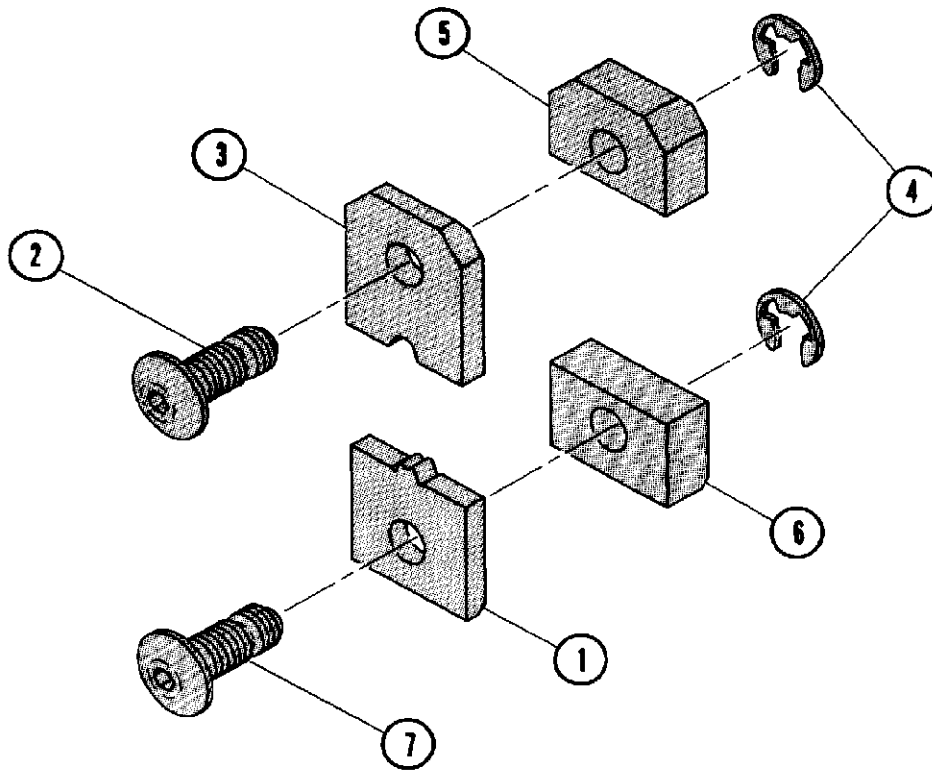

Figure 7



ITEM NUMBER	DESCRIPTION	QUANTITY	DIE SET NUMBERS AND COMPONENT PART NUMBERS					
			47812	47813	47814	47814 Mod. H	47815	69819
1	MOVING DIE	1	305833-1	305833-3	305833-6	45949-9	305833-5	306938
2	SCREW	1	1-305927-8	1-305927-8	1-305927-9	1-305927-9	1-305927-8	1-305927-9
3	STATIONARY DIE	1	305834-1	305834-4	305834-7	305834-7	305834-6	306937
4	RING, RETAINING	2	1- 21046-3	1- 21046-3	1- 21046-3	1- 21046-3	1- 21046-3	1- 21046-3
5	SPACER	1	305832-3	305832-3	1-305832-2	1-305832-2	305832-3	1-305832-2
6	SPACER	1	305832-4	305832-4	2-305832-5	2- 59675-9	305832-9	2- 59675-2
7	SCREW	1	9-306105-1	9-306105-1	1-305927-8	1-305927-8	1-305927-8	1-305927-8

Figure 8

REL. DATE	REV. DATE	APPROVALS	
11-15-57	4-29-74	ENG. <i>James S. Bell.</i>	PUB. <i>Paul Felty</i>