



Chipsmall Limited consists of a professional team with an average of over 10 year of expertise in the distribution of electronic components. Based in Hongkong, we have already established firm and mutual-benefit business relationships with customers from,Europe,America and south Asia,supplying obsolete and hard-to-find components to meet their specific needs.

With the principle of “Quality Parts,Customers Priority,Honest Operation,and Considerate Service”,our business mainly focus on the distribution of electronic components. Line cards we deal with include Microchip,ALPS,ROHM,Xilinx,Pulse,ON,Everlight and Freescale. Main products comprise IC,Modules,Potentiometer,IC Socket,Relay,Connector.Our parts cover such applications as commercial,industrial, and automotives areas.

We are looking forward to setting up business relationship with you and hope to provide you with the best service and solution. Let us make a better world for our industry!



## Contact us

Tel: +86-755-8981 8866 Fax: +86-755-8427 6832

Email & Skype: info@chipsmall.com Web: www.chipsmall.com

Address: A1208, Overseas Decoration Building, #122 Zhenhua RD., Futian, Shenzhen, China





# 480V:347V:277V Series

## Step-Down Autotransformers

### for Lighting Applications

Rev 8-8-2017

Intelligent Device  
**ECOSYSTEM**  
Classic

### Features

Step-down autotransformers designed especially for lighting applications, typically used with 277V LED Drivers, T-5 or T-8 Electronic Fluorescent Ballasts or Electronic HID Ballasts in Industrial and Commercial applications.

- Input Voltage: 480V, 60 Hz or 347V, 60 Hz
- Output Voltage: 277V, 60 Hz
- Insulation Rating: 125 & 460– 105°C, 245– 130°C
- Non-isolated Autotransformer
- 5 Year Warranty - Industry Leading



Model	Losses	Input Current Max Load	Input Current No Load	Weight (lbs)
480:347:277-125VA	7W	0.26A	0.070A	2.3
480:347:277:220-245VA	10W	0.57A	0.080A	5.3
480:347:277-460VA	18W	0.95A	0.220A	7.2

### Dimensions

Model	A (in)	B (in)	C (in)	D (in)	E (in)
125VA	See drawing below (mm)				
245VA	3.39	2.83	2.81	2.61	3.14
460VA	3.78	3.23	3.19	2.95	3.31

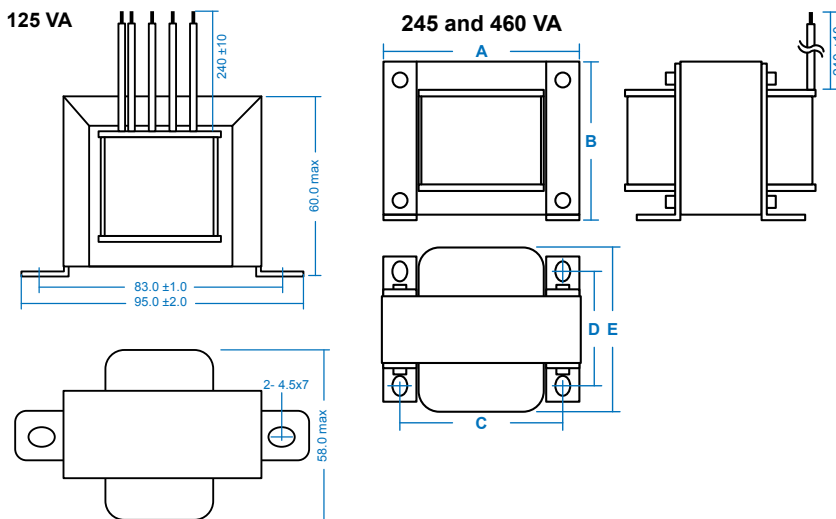

### Wiring

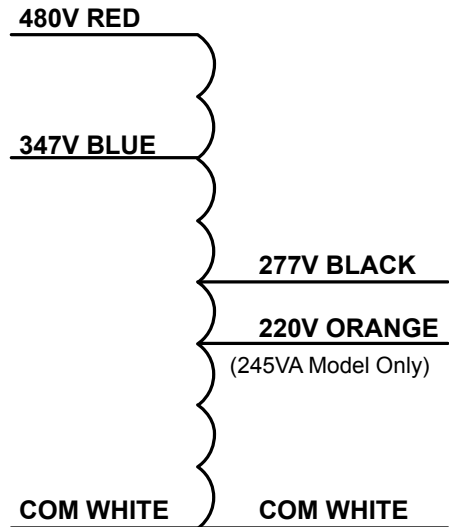

#### Wiring Notes:

- Wye 480V system—Connect red (or blue for 347V) and white wires to any two phase wires.
- Delta 480V—Connect to grounded referenced legs only.

